

# Service Workbook

## 1.8 Diesel Engine

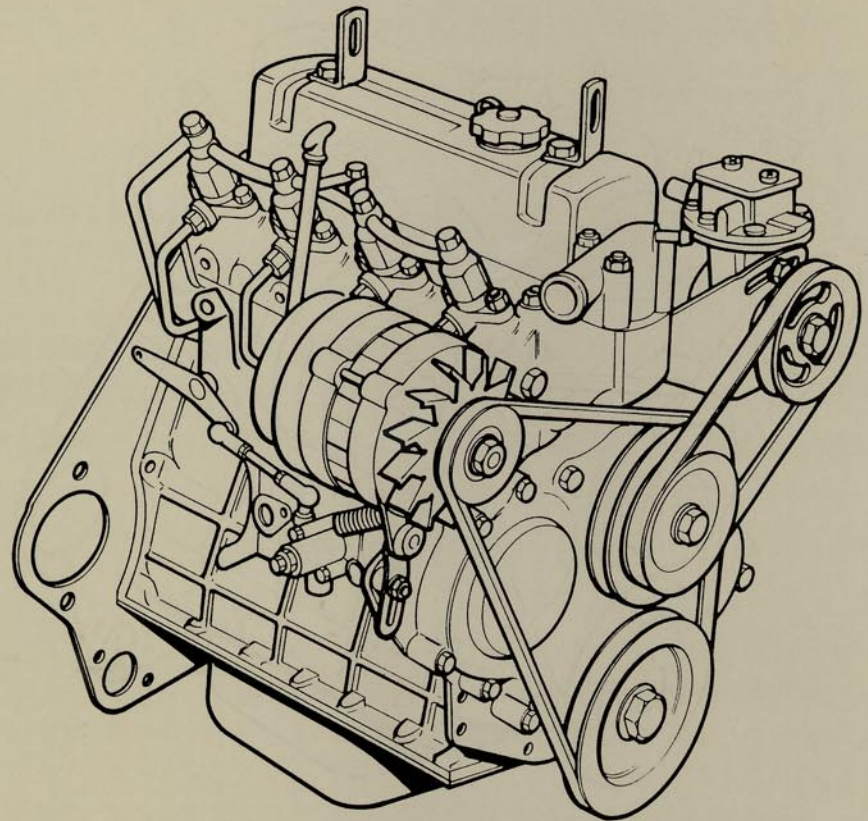

## **1.8 DIESEL ENGINE**

# **SERVICE WORKBOOK**

Leyland DAF Vans are constantly seeking ways to improve the specification and design of its vehicles and alterations take place continually.

Whilst every effort is made to produce up to date literature, this service workbook should not be regarded as an infallible guide to current specifications, nor does it constitute an offer for the fitment of any particular system or component.

All rights reserved. No part of this service workbook may be reproduced without prior permission:

This service workbook should always be consulted prior to servicing or repair work.

Leyland DAF Vans  
Marketing & Sales  
1 Cornwall Street,  
Birmingham B3 2DT

© Leyland DAF 1990

**CONTENTS**

	<i>Page</i>
Introduction .....	2
Data .....	4
Special Tools .....	7
Torque Wrench Settings .....	9
Recommended Lubricants .....	10
Service Summary .....	10
Engine Tuning Data .....	11
<b>Component Removal:</b>	
Cylinder Head .....	12
Sump .....	12
Timing Gear Cover, Timing Chain and Gears .....	12
Front Plate .....	13
Oil Pump and Drive Shaft .....	14
Crankshaft .....	14
Pistons and Connecting Rods .....	15
Camshaft .....	16
<b>Component Overhaul:</b>	
Rocker Shaft .....	16
Cylinder Head .....	17
Timing Gears, Chain Tensioner and Chain .....	18
Crankshaft and Bearings .....	18
Pistons and Connecting Rods .....	19
Oil Pump .....	19
Oil Pressure Relief Valve .....	19
Camshaft and Bearings .....	20
Tappets .....	20
<b>Reassembly:</b>	
Tappets .....	20
Camshaft .....	20
Crankshaft .....	20
Pistons and Connecting Rods .....	21
Oil Pump .....	21
Oil Sump .....	21
Front Mounting Plate .....	21
Camshaft End Float .....	21
Crankshaft and Camshaft Gear Alignment .....	21
Timing Cover and Gearbox Adaptor Plate .....	21
Cylinder Head .....	22
<b>Fuel System:</b>	
Data .....	23
Special Tools .....	23
Diagnostic Tools .....	24
Torque Wrench Settings .....	24
Fuel System Layout and Operation .....	25
Fuel Filter .....	25
Flight Speed – Check and Adjust .....	26
Idle Speed and Anti-stall Setting .....	26
Bleeding the Fuel System .....	27
Fuel Lift Pump – Dismantle and Reassembly .....	28
Fuel Injection Pump – Remove and Refit .....	28
Fuel Injection Pump Timing .....	29
Injectors – Remove, Overhaul and Refit .....	30
Fuel Injection Equipment – Fault Diagnosis .....	31
Injectors – Fault Diagnosis .....	32
<b>Heater Plug System:</b>	
Early Type (Prior to VIN 258340) .....	33
Later Type (After VIN 258340) .....	38
Heater Plug Testing (Both systems) .....	39
Heater Plug Circuit Testing .....	39

## **INTRODUCTION**

This Service Workbook covers the 1.8 Diesel engine fitted to Sherpa K2/200 Series. It is primarily designed to assist skilled technicians in the efficient repair and maintenance of 1.8 Diesel engines.

**WARNINGS** and **CAUTIONS** are given throughout this Service Workbook in the following form:

**WARNING:** Procedures which must be followed precisely to avoid the possibility of personal injury.

**CAUTION:** This calls attention to procedures which must be followed to avoid damage to components.

**NOTE:** This calls attention to methods which make a job easier to perform.

## **REFERENCES**

References to the left-or-right hand side in the Service Workbook are made when viewing the vehicle from the rear. With the engine and gearbox assembly removed, the water pump end of the engine is referred to as the front.

To reduce repetition, operations covered in this Workbook do not include reference to testing the vehicle after repair. It is essential that work is inspected and tested after completion and if necessary a road test of the vehicle is carried out particularly where safety related items are concerned.

## **DIMENSIONS**

The dimensions quoted are to design engineering specification. Alternative unit equivalents, shown in brackets following the dimensions, have been converted from the original specification.

During the period of running-in from new, certain adjustments may vary from the specification figures given in this Service Workbook. These adjustments will be re-set by the Dealer at the After Sales Service, and thereafter should be maintained at the figures specified in the Service Workbook.

## **REPAIRS AND REPLACEMENTS**

When replacement parts are required it is essential that only Leyland DAF parts are used.

## **POISONOUS SUBSTANCES**

Many liquids and other substances used in motor vehicles are poisonous and should under no circumstances be consumed and should as far as possible be kept away from open wounds. These substances among others include antifreeze, brake fluid, windscreen additives, lubricants and various adhesives.

## **FUEL HANDLING PRECAUTIONS**

The following information provides basic precautions which must be observed if fuel is to be handled safely. It also outlines the other areas of risk which must not be ignored.

This information is used for basic guidance only, and in any case of doubt enquiries should be made of your local Fire Officer.

## GENERAL

Always have a fire extinguisher containing FOAM CO<sub>2</sub> GAS, or POWDER close at hand when handling or draining fuel, or when dismantling fuel systems and in areas where fuel containers are stored.

Always disconnect the vehicle battery BEFORE carrying out dismantling or draining work on a fuel system. Whenever fuel is being handled, drained or stored, or when fuel systems are being dismantled all forms of ignition must be extinguished or removed, any hand-lamps used must be flameproof and kept clear of spillage.

## FUEL TANK DRAINING

**WARNING: FUEL MUST NOT BE EXTRACTED OR DRAINED FROM ANY VEHICLE WHILST IT IS STANDING OVER A PIT.**

The receptacle used must be more than adequate for the full amount of fuel to be extracted or drained. The receptacle should be clearly marked with its contents, and placed in a safe storage area which meets the requirements of local authority regulations.

## FUEL TANK REMOVAL

On vehicles where the fuel line is secured to the fuel tank outlet by a spring steel clip, it is recommended that such clips are released before the fuel line is disconnected or the fuel tank unit is removed. This procedure will avoid the possibility of residual fumes in the fuel tank being ignited when the clips are released.

## FUEL TANK REPAIR

Under no circumstances should a repair to any tank involving heat treatment be carried out without first rendering the tank SAFE, by using one of the following methods:

**STEAMING:** With the filler cap and tank unit removed, empty the tank. Steam the tank for at least two hours with low pressure steam. Position the tank so that condensation can drain away freely, ensuring that any sediment and sludge not volatilised by the steam, is washed out during the steaming process.

**BOILING:** With the filler cap and tank unit removed, empty the tank. Immerse the tank completely in boiling water containing an effective alkaline degreasing agent or a detergent, with the water filling and also surrounding the tank for at least two hours.

After steaming or boiling a signed and dated label to this effect should be attached to the tank.

## SPECIFICATION

Purchasers are advised that the specification details set out in this Service Workbook apply to a range of vehicles and not to any one. For the specification of a particular vehicle, purchasers should consult their Dealer.

The Manufacturers reserve the right to vary their specifications with or without notice, and at such times and in such manner as they think fit. Major as well as minor changes may be involved in accordance with the Manufacturer's policy of constant product improvement.

Whilst every effort is made to ensure the accuracy of particulars contained in this Service Workbook, neither the Manufacturer nor the Dealer, by whom this Service Workbook is supplied, shall in any circumstances be held liable for any inaccuracy or the consequences thereof.

**DATA**

<b>Number of Cylinders</b>	4	
<b>Bore</b>	80.26mm	3.16in
<b>Stroke</b>	88.9mm	3.5in
<b>Capacity</b>	1799cm <sup>3</sup>	109.8in <sup>3</sup>
<b>Injection order</b>	1, 3, 4, 2	
<b>Valve Operation</b>	Overhead by push rod	
<b>Compression ratio</b>	22.36:1	
<b>Torque (gross)</b>	11 kgf.m; (108Nm); 79.7 lbf.ft at 2.500 rev/min.	
<b>Crankshaft</b>		
Main journal diameter	54,005 to 54,025 mm	2.1262 to 2.1270in
Crankpin journal diameter	47,65 to 47.66mm	1.8759 to 1.8764in
Crankshaft end thrust	Taken on thrust washers at centre main bearing	
Crankshaft end float	0.03 to 0.14mm	0.001 to 0.0055in
Thrust washer thicknesses	2.25 to 2.30mm	0.0885 to 0.0905in
	2.31 to 2.36mm	0.091 to 0.093in
	2.37 to 2.43mm	0.0935 to 0.0955in
<b>Main bearings</b>		
Number and type	5 - Steel backed, lead indium	
Length: Front, centre and rear	28.45 to 28.70mm	1.120 to 1.130in
Intermediate	19.30 to 19.55mm	0.760 to 0.770in
Diametrical clearance	0.025 to 0.076mm	0.001 to 0.003in
<b>Connecting rods</b>		
Type	Horizontally split big end, plain small end	
Length between centres	157.9 to 158.0mm	6.220 to 6.222in
<b>Connecting rod alignment</b>		
Maximum out of parallel of big ends and little ends	0.004 cm per cm effective mandrel length	0.004 inch per inch
<b>Connecting rod bush</b>		
Clearance on gudgeon pin	0.005 to 0.023mm	0.0002 to 0.0009in
Inside diameter (reamed after fitting)	25.41 to 25.42mm	1.0002 to 1.0007in
<b>Big end bearings</b>		
Type	Steel backed, lead indium	
Length	19.68 to 19.93mm	0.775 to 0.785in
Diametrical clearance	0.025 to 0.068mm	0.001 to 0.0027in
<b>Gudgeon pin</b>		
Type	Fully floating with circlip location	
Fit in piston (clearance)	0.002 to 0.007mm	0.0001 to 0.0003in
Fit in connecting rod (clearance)	0.005 to 0.023mm	0.0002 to 0.0009in
Diameter (outer)	25.39 to 25.40mm	0.998 to 1.000in
<b>Pistons</b>		
Type	Aluminium alloy, solid skirt with open combustion cavity	

Clearances: in bore:				
Top land			0.43 to 0.57mm	0.0171 to 0.0211in
Bottom land			0.35 to 0.44mm	0.0137 to 0.0172in
Bottom of skirt			0.10 to 0.13mm	0.004 to 0.005in
Oversize available			0.508mm	0.020in
<b>Piston stand proud</b>			0.33 to 0.53mm	0.013 to 0.021in
<b>Compression height</b> (from centre line of gudgeon pin to piston crown) (service only)			50.22 to 50.27mm	1.977 to 1.979in
<b>Piston rings</b>				
<b>Compression</b>				
Type:	Top		Chrome faced	
	Second		Tapered, sintered alloy	
Width			1.96 to 1.98mm	0.0771 to 0.0781in
Fitted gap:	Top		0.304 to 0.431mm	0.012 to 0.017in
	Second		0.31 to 0.56mm	0.012 to 0.022in
Ring to groove clearance:	Top		0.06 to 0.11mm	0.0025 to 0.0045in
	Second		0.04 to 0.09mm	0.0015 to 0.0035in
<b>Oil control</b>				
Type			Slotted scraper	
Fitted gap			0.30 to 0.43mm	0.012 to 0.017in
Ring to groove clearance			0.04 to 0.09mm	0.0015 to 0.0035in
<b>Rocker gear</b>				
Rocker shaft diameter			15.85 to 15.87mm	0.624 to 0.625in
Rocker bush inside diameter (reamed in position)			15.89 to 15.90	0.6255 to 0.626in
<b>Camshaft</b>				
Journal diameters:	Front		49.56 to 49.57mm	1.95125 to 1.95175in
	Centre		48.76 to 48.77	1.91975 to 1.92025in
	Rear		43.91 to 43.92mm	1.72875 to 1.72925in
Bearing liner inside diameter:	Front		49.60 to 49.61mm	1.95275 to 1.95325in
	Centre		48.80 to 48.81mm	1.92125 to 1.92175in
	Rear		43.95 to 43.96mm	1.73025 to 1.73075in
Diametrical clearance			0.02 to 0.05mm	0.001 to 0.002in
End Thrust			Taken on locating plate	
End float			0.08 to 0.18mm	0.003 to 0.007in
<b>Timing gear alignment - Crankshaft gear forward of camshaft gear</b>			0.000 to 0.13mm	0.000 to 0.005in
<b>Tappets</b>				
Type			Bucket	
Outside diameter			20.606 to 20.618mm	0.81125 to 0.81175in
Length			37.97 to 38.23mm	1.495 to 1.505in
<b>Valves</b>				
Seat angle:	Inlet		45 degrees	
	Exhaust		45 degrees	
Head diameter:	Inlet		36.42 to 36.55mm	1.434 to 1.439in
	Exhaust		30.64 to 30.78mm	1.207 to 1.212in
Stem diameter:	Inlet		8.70 to 8.72mm	0.3428 to 0.3433in
	Exhaust		8.69 to 8.70mm	0.3421 to 0.3428in
Stem to guide clearance:	Inlet		0.02 to 0.05mm	0.0008 to 0.0020in
	Exhaust		0.03 to 0.06mm	0.0013 to 0.0027in

Valve lift: Inlet	8.96mm	0.352in
Exhaust	9.27mm	0.364in
Valve stand down - inlet and exhaust	0.508 to 0.762mm	0.02 to 0.03in
<b>Valve guides</b>		
Length: Inlet/exhaust	56.39mm	2.22in
Outside diameter: Inlet/exhaust	14.31 to 14.33mm	0.5635 to 0.5640in
Inside diameter: Inlet/exhaust (reamed after fitting)	8.74 to 8.76mm	0.3441 to 0.3448in
Fitted height above spring seat: Inlet/exhaust	13.9 to 14.2mm	0.55 to 0.56in
Interference fit in head: Inlet/exhaust	0.013 to 0.044mm	0.0005 to 0.0018in
<b>Valve springs</b>		
Free length	48.77mm	1.92in
Fitted length	36.57mm	1.44in
Load at fitted length	37.19kgf 364N	82 lbf
Load at top of lift	64.4kgf 631N	142 lbf
Number of working coils	4.5	
<b>Valve timing</b>		
Timing marks	Dimples on timing wheels, marks on flywheel	
Rocker clearance: Running (cold)	0.36mm	0.014in
Timing	0.41mm	0.016in
Inlet valve: Opens	8 degrees B.T.D.C.	
Closes	44 degrees A.B.D.C.	
Exhaust valve: Opens	50 degrees B.B.D.C.	
Closes	10 degrees A.T.D.C.	
<b>Cylinder head</b>		
Maximum warp and twist	0.10mm	0.004in
Depth after refacing	80.26mm minimum	3.16in minimum
<b>Cylinder block</b>		
Bore: Standard	80.251 to 80.279mm	3.1595 to 3.1606in
Service oversize (without cylinder liner)	0.508mm	0.020in
To accept cylinder liner, machine bores to	82.84 to 82.86mm	3.2615 to 3.2620in
<b>Cylinder liners</b>		
Outside diameter	82.92 to 82.96mm	3.2645 to 3.2660in
Bore: Standard (machined after fitting)	80.251 to 80.279mm	3.1595 to 3.1606in
Oversize	0.508mm	0.020in
<b>Lubrication</b>		
System	Wet sump, pressure fed	
System pressure : Running	3.52 kgf/cm <sup>2</sup> (3.5 bar)	50 lbf/in <sup>2</sup>
Idling	1.05 kgf/cm <sup>2</sup> (1.0 bar)	15 lbf/in <sup>2</sup>
Oil pump	Rotor type	
Outer rotor end float	0.055 to 0.093mm	0.0022 to 0.0037 in
Inner rotor end float	0.055 to 0.093mm	0.0022 to 0.0037in
Outer rotor to pump body diametrical clearance	0.141 to 0.19mm	0.0055 to 0.0075in
Rotor lobe clearance	0.15mm max	0.006in max
<b>Oil filter</b>		
	Full flow, disposable cartridge type	
<b>Oil pressure relief valve</b>		
	3.52 kgf/cm <sup>2</sup> (3.5 bar)	50 lbf/in <sup>2</sup>
Relief valve spring: Free length	76mm	3.0in
Fitted length	54.77mm	2.156in
Load at fitted length	7.0 to 7.4kgf (69 to 73N) 15.5 to 16.5 lbf	



**SPECIAL TOOLS**

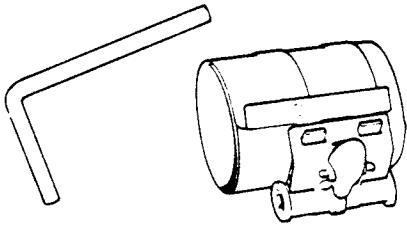

18G 55A Piston ring clamp

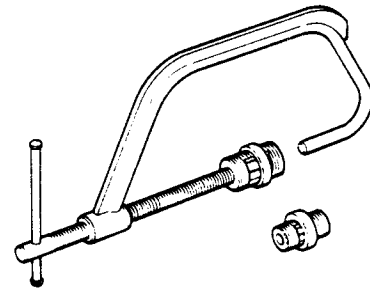

18G 106A Valve spring compressor  
(18G 1519A equivalent)

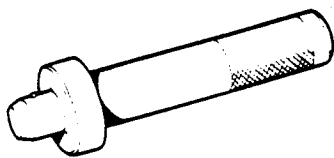

18G 134 Driver handle

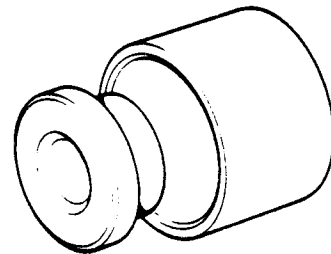

18G 134BD Timing cover oil seal replacer

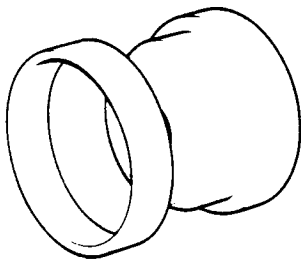

18G134CQ Crankshaft rear oil seal replacer

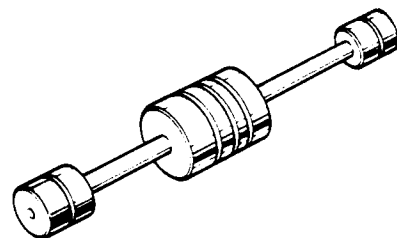

18G 284 Impulse extractor

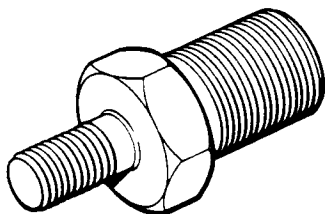

18G 284-12 Main bearing cap remover

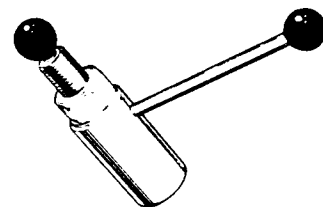

FR 581 Spigot bearing remover

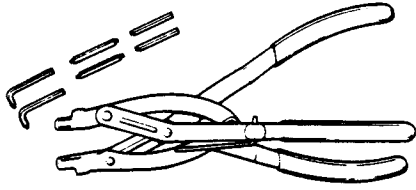

18G 1004 Circlip pliers

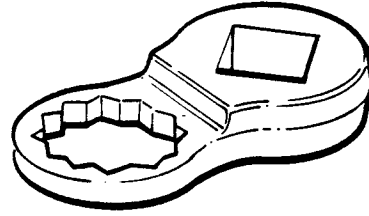

<sup>11</sup>/<sub>16</sub>" AF x <sup>1</sup>/<sub>2</sub>" Square drive  
18G 694A Cylinder head nut crowfoot wrench

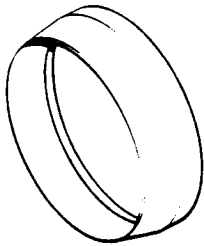

18G 1108 Crankshaft rear oil seal protector sleeve

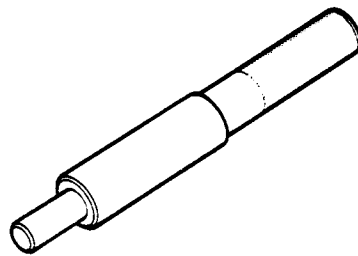

18G 1195 Clutch centralizing tool

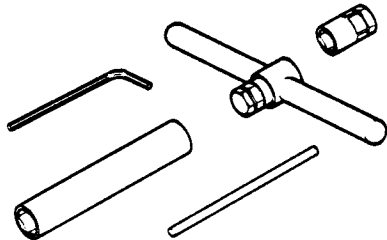

MS 76 Basic handle set

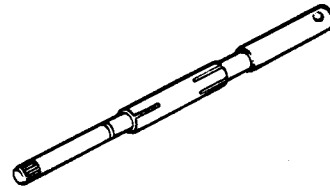

MS 150-8.5 Expandable pilot

MS.621

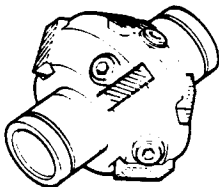

MS 204 Adjustable valve seat cutter

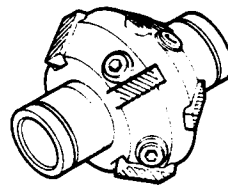

MS 621 Adjustable valve seat cutter

## TORQUE WRENCH SETTINGS

	Nm	lbf.ft.	kgf.m
Cylinder head nuts	102	75	10.4
Rocker bracket nuts	34	25	3.5
Manifold nuts	20	15	2.1
Big end nuts	47	35	4.8
Main bearing set screws	102	75	10.4
Flywheel bolts	54	40	5.5
Timing cover bolts: $\frac{1}{4}$ in	8	6	0.8
$\frac{5}{16}$ in	27	20	2.8
Rear plate bolts: $\frac{5}{16}$ in	27	20	2.8
$\frac{3}{8}$ in	41	30	4.1
Camshaft nut	88	65	9.0
Crankshaft bolt (discard lockwasher)	156	115	16
Idler gear hub bolt	41	30	4.1
Cylinder side cover set screws	5.4	4	0.5
Rocker cover nuts	5.4	4	0.5
Sump bolts	8	6	0.8
Oil filter adaptor	41	30	4.1
Oil pump nuts	22	16	2.2
Oil pressure release valve – domed nut	61	45	6.2
Starter motor bolts	47	35	4.8
Clutch to flywheel	34	25	3.5
Fuel lift pump nuts	16	12	1.7
Injector nozzle nut	68	50	6.9
Injection pump nuts	24	18	2.5
Injection pipe nuts	16	12	1.7
Injection pump driving flange set screws	14	10	1.4
Water pump bolts	23	17	2.3
Water pump pulley set screws	24	18	2.5
Alternator pulley nut	36.5	27	3.7
Thermal transmitter	22	16	2.2
Heater plug to cylinder head	16	12	1.6
Heater plug cable securing nut	5.4	4	0.5

**RECOMMENDED LUBRICANTS**

Multipart Multigrade Super 10W40

**SERVICE SUMMARY**

	MILEAGE			
	1000	6000 18000	12000	24000
RENEW ENGINE OIL AND FILTER	●	●*	●	●
RENEW FUEL FILTER			●	●
CHECK GLOW PLUG OPERATION			●	●
CHECK ALTERNATOR DRIVE BELT TENSION			●	RENEW
CHECK ANTIFREEZE SOLUTION- 33 1/3% (NB 33 1/3% SOLUTION FOR TOP UP)	●		●	RENEW COOLANT
RENEW AIR FILTER ELEMENT			●	●
CHECK/ADJUST VALVE CLEARANCES	●		●	●
CHECK/TOP UP OIL LEVEL IN VACUUM PUMP (IF FITTED)				●
CHECK VACUUM PUMP DRIVE BELT – ADJUST OR RENEW			●	RENEW
RENEW ENGINE OIL FILLER CAP				●
CHECK SECURITY OF VACUUM PUMP ATTACHMENT				●

\* VEHICLES MANUFACTURED PRIOR TO 1980 – OIL AND FILTER MUST BE CHANGED AT 3,000 MILE INTERVALS.

NOTE: VEHICLES SUBJECT TO ARDUOUS STOP START OPERATION SHOULD HAVE OIL AND FILTER CHANGE AT 3000 MILE INTERVALS

**ENGINE TUNING DATA****Engine**

Displacement	1799 cm <sup>3</sup>	109.8in <sup>3</sup>
Injection order	1, 3, 4, 2.	
Compression ratio	22.36 : 1	
Valve rocker clearance (cold) Inlet and exhaust	0.36mm	0.014in

**Fuel Injection Pump**

Make and type	C.A.V. DPA 3247F401
Injection pump timing (static)	18 degrees B.T.D.C.

**Fuel Injectors**

Make and type	C.A.V. Pintaux
Nozzle type	BDN.OSPC.6651
Nozzle holder type	BKB.35SD.5188
Opening pressure	135 atmospheres

**Heater plugs**

Make (prior to VIN258340)	Champion CH62
Make (VIN258340 on)	Bosch
Tip starts to glow	5 seconds
Initial current draw	25 amps at 12 volts
Current draw after 20 seconds	12 amps at 12 volts

## THE FOLLOWING PROCEDURE DETAILS UNIT DISMANTLING AND RE-BUILD WITH THE ENGINE REMOVED FROM THE VEHICLE.

### DISMANTLING

#### CYLINDER HEAD

1. Remove injector pipes, spill return pipes, injection pump oil feed pipe and alternator.
2. Disconnect harness from heater plugs.
3. Remove dipstick, release tube from cylinder head nut.
4. Remove rocker cover and vacuum pump bracket.

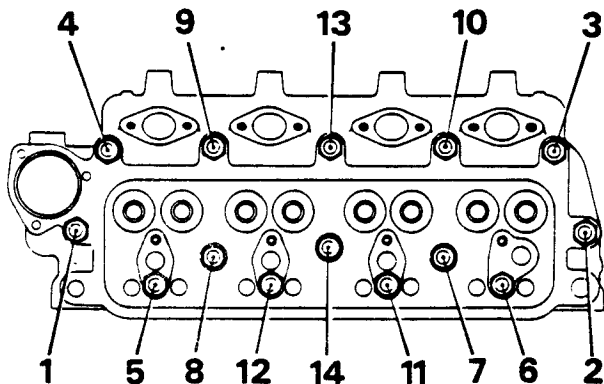

Fig. 1 Cylinder head nut removal sequence

5. Remove cylinder head nuts in sequence shown in Fig. 1. To remove the three nuts beneath the rocker shaft use special tool 18G 694A or a suitable  $1\frac{1}{16}$  in A/F crowfoot socket.
6. Remove rocker shaft assembly, noting locking plate on rear pedestal and shims beneath centre pedestals.
7. Withdraw push rods; retain in fitted order.
8. Lift off cylinder head.

**NOTE:** Combustion chamber inserts may drop out of cylinder head as it is lifted. Identify each insert to its original fitted position before proceeding.

#### SUMP

1. Remove sump securing bolts and washers.
2. Lift off sump and discard the gasket.

#### TIMING GEAR COVER, TIMING CHAIN AND GEARS

1. Remove the fuel injection pump (see section Fuel Injection Pump - Removal).
2. Bend back the front crankshaft pulley lockwasher (if fitted) and, restraining the flywheel, remove the crankshaft pulley bolt. Discard the lockwasher (if fitted) and remove the pulley.

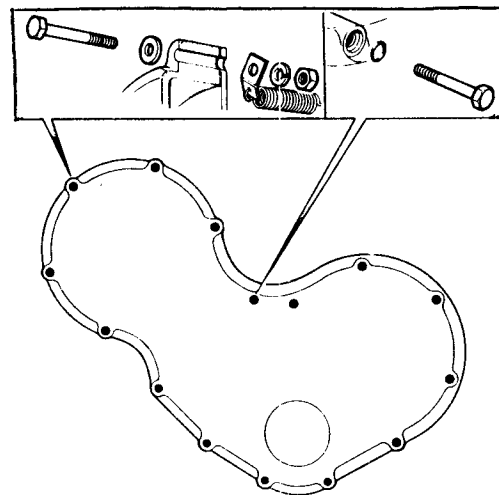

Fig. 2 Timing cover

3. Remove the timing cover nuts and bolts, noting the position of the rubber 'O' ring (if fitted) and throttle return spring bracket. (See Fig.2).
4. Remove the timing cover and discard the gasket.

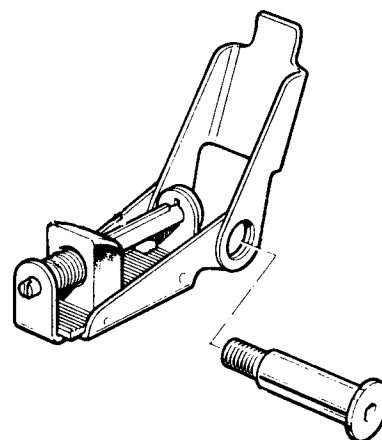
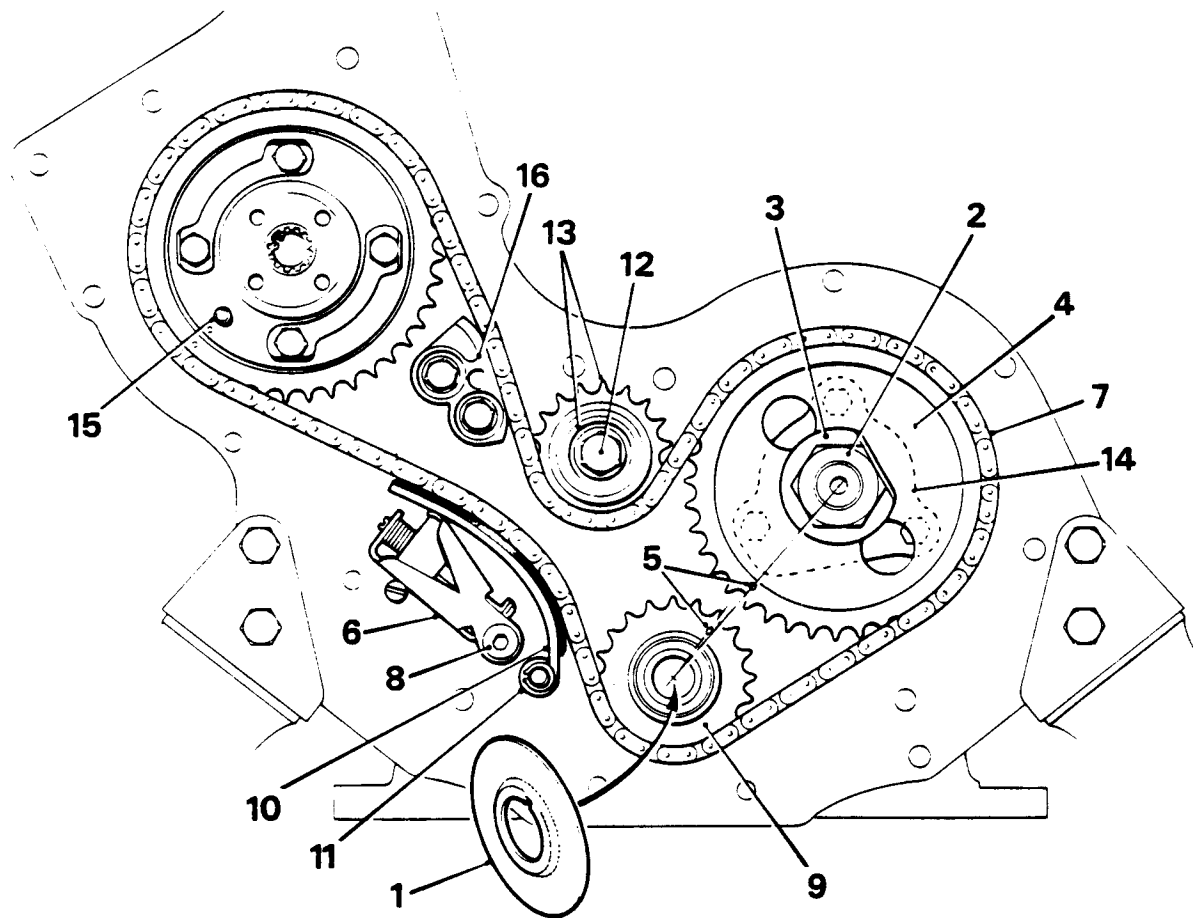
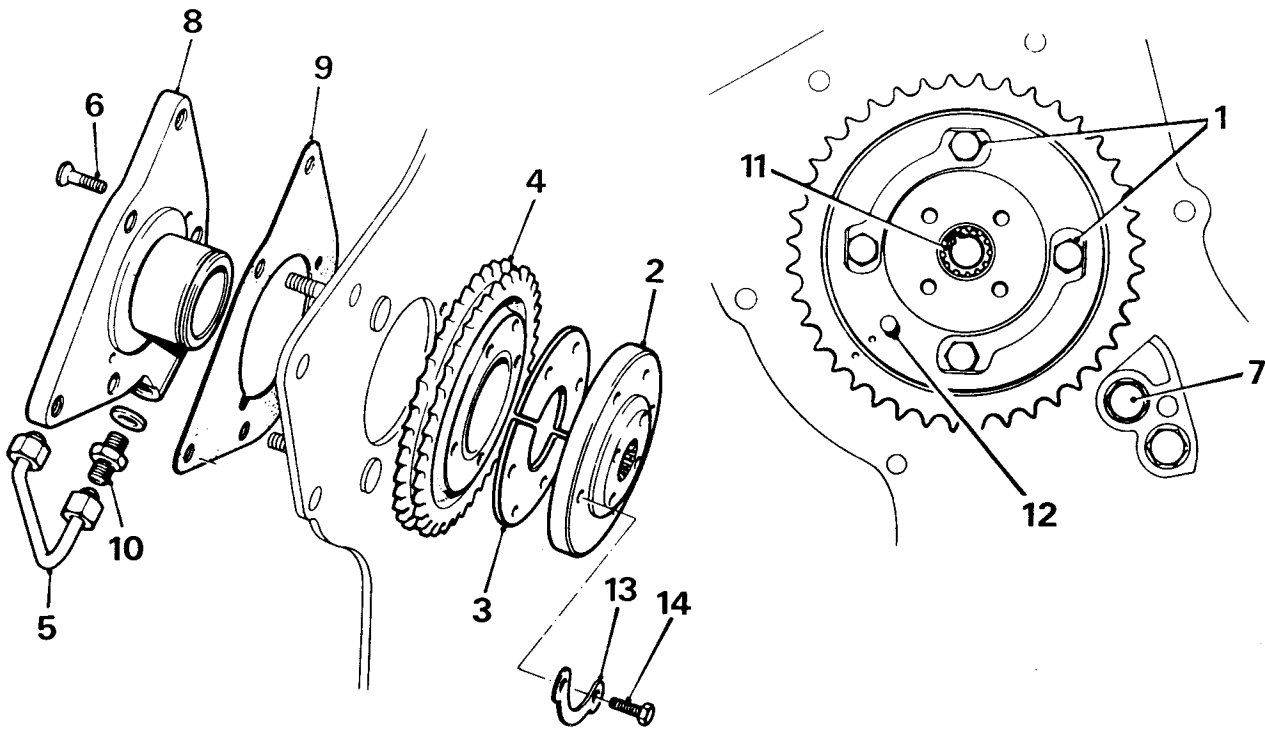

Fig. 3 Timing chain tensioner



**Fig. 4 Timing chain and gears**

- |  |   |
|--|---|
| <ol style="list-style-type: none"> <li>1. Crankshaft oil thrower</li> <li>2. Camshaft gear nut</li> <li>3. Tab washer</li> <li>4. Camshaft gear</li> <li>5. Timing marks</li> <li>6. Timing chain tensioner</li> <li>7. Timing chain</li> <li>8. Chain tensioner securing screw</li> </ol> | <ol style="list-style-type: none"> <li>9. Crankshaft gear</li> <li>10. Chain tensioner pad</li> <li>11. Circlip and pivot pin</li> <li>12. Idler gear bolt</li> <li>13. Idler gear and hub</li> <li>14. Camshaft locating plate</li> <li>15. Injection pump gear timing hole</li> <li>16. Chain vibration damper</li> <li>17. Chain tensioner centre pin</li> </ol> |
|--|---|
- 
5. Identify the fitted position (convex face to the front) of the front crankshaft oil thrower and remove it.
  6. After ensuring the timing marks are identifiable, keep the timing chain tensioner in its running position, and remove the Allen screw retaining the tensioner assembly. Remove the tensioner. (See Fig.3).
  7. Remove the idler gear bolt and withdraw the bolt and gear centre hub.  
**NOTE:** The gear centre hub locates on a roll pin.
  8. Remove the timing chain from the sprockets.  
**NOTE:** If the cylinder head is still fitted to the engine, it is imperative that neither the camshaft nor crankshaft are turned whilst the chain is removed.
  9. Bend back the camshaft gear nut lockwasher, and whilst restraining the camshaft gear, remove the camshaft gear nut. Remove the gear.
  10. Remove crankshaft gear, recover the shim(s) and Woodruff keys.
  11. Bend back lockwashers and remove bolts securing injection pump drive flange. Withdraw flange. Recover two locating half plates.
  12. Withdraw injection pump gear. Remove injection pump hum.
  13. Remove camshaft locating plate and chain vibration damper.
  14. Remove front engine mounting brackets and mounting plate securing bolts. Withdraw the mounting plate and discard the gasket.



**Fig. 5 Injection pump flange, gear and hub**

- |                                |                                |
|--------------------------------|--------------------------------|
| 1. Drive flange securing bolts | 8. Injection pump hub          |
| 2. Drive flange                | 9. Gasket                      |
| 3. Locating half plates        | 10. Union                      |
| 4. Injection pump gear         | 11. Fitted position of circlip |
| 5. Oil feed pipe               | 12. Timing hole                |
| 6. Flange securing screw       | 13. Tab washer                 |
| 7. Chain vibration damper bolt | 14. Drive flange securing bolt |

### Oil Pump and Driveshaft

1. Remove nuts securing oil pump. Withdraw pump and driveshaft assembly.
2. Remove the oil strainer.

### Crankshaft

1. Bend back the flywheel bolt lock tabs. Restrain the flywheel and remove the flywheel bolts. Discard the locktab.
2. Remove the flywheel.
3. Remove the retaining bolts and adaptor plate. Discard the gasket.  
**NOTE:** Adaptor plate is located on two dowels.
4. Suitably identify each big-end bearing cap to its original location.
5. Remove the big end bearing caps and shells. Keep each shell with its respective bearing cap.
6. Suitably identify each main bearing CP to its original location.
7. Working from the centre, remove main bearing cap securing bolts. Remove main bearing caps (using 18G 284 and 18G 284-12 if available).
9. Recover lower halves of main bearing shells keeping each shell with its respective cap.
10. Lift out crankshaft. Recover upper bearing shells and thrust washers noting their fitted positions.



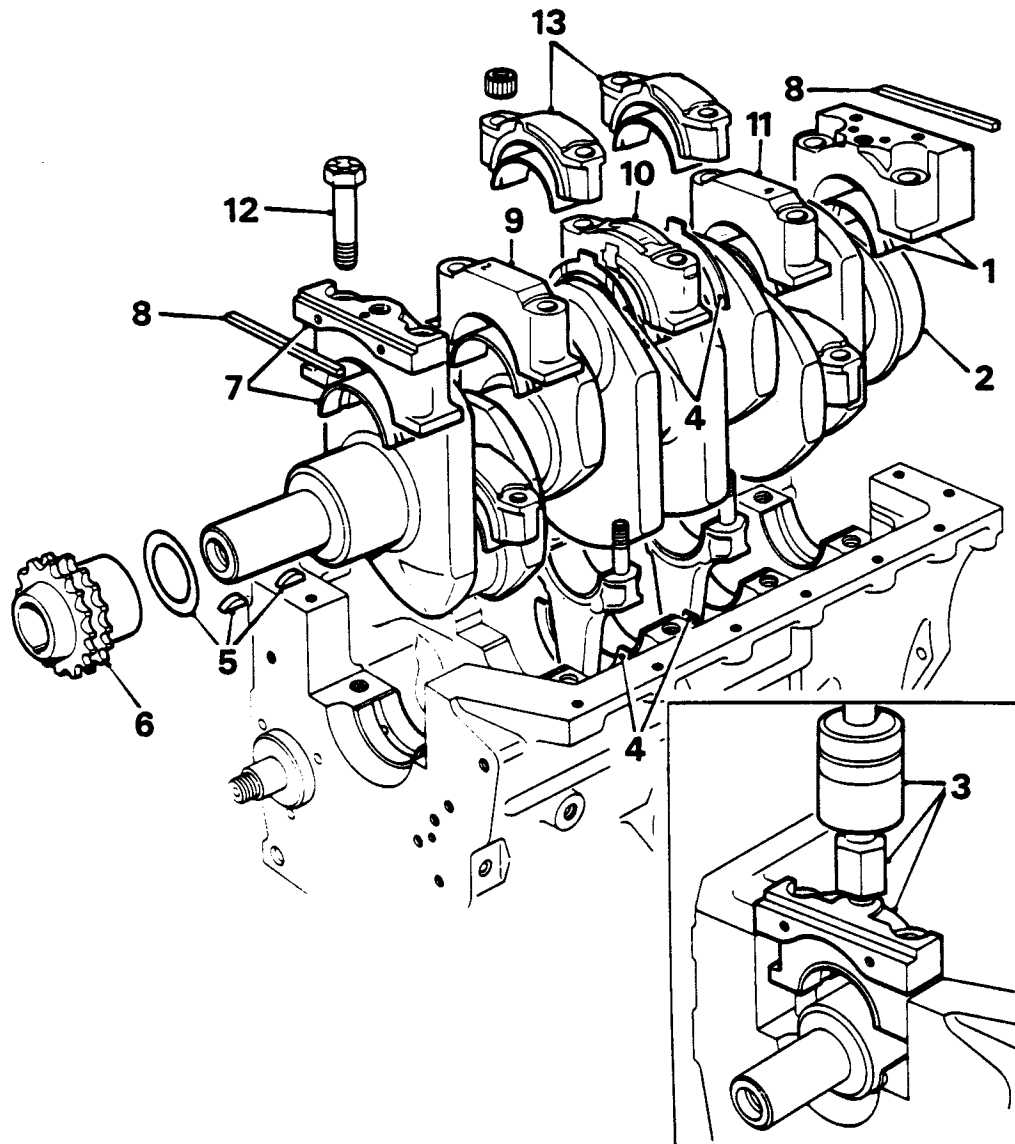

**Fig. 6 Crankshaft and bearing removal**

- |   |   |
|---|---|
| <ol style="list-style-type: none"> <li>1. Rear main bearing cap and shell</li> <li>2. Crankshaft rear journal</li> <li>3. Main bearing cap removal</li> <li>4. Thrust washers</li> <li>5. Woodruff keys and shim(s)</li> <li>6. Crankshaft gear</li> <li>7. Front main bearing cap and shell</li> </ol> | <ol style="list-style-type: none"> <li>8. Cork sealing strips</li> <li>9. No. 2 main bearing cap</li> <li>10. Centre main bearing cap</li> <li>11. No. 4 main bearing cap</li> <li>12. Main bearing bolt</li> <li>13. Big end bearing cap and shells</li> </ol> |
|---|---|

**Connecting Rods and Pistons**

- |   |  |
|---|--|
| <ol style="list-style-type: none"> <li>1. Identify each piston and connecting rod assembly with the respective cylinder bore.</li> <li>2. Remove any excess carbon from the top of the cylinder bore and withdraw the pistons and connecting rod assemblies.</li> </ol> | <ol style="list-style-type: none"> <li>3. Recover upper big end bearing shells identifying each shell with its respective connecting rod.</li> </ol> |
|---|--|

## Camshaft

1. Remove fuel lift pump.
2. Support the cylinder block with its cylinder head gasket face resting on wooden blocks.
3. Rotate camshaft to position all the tappets away from the cams.
4. Withdraw the camshaft and recover the tappets ensuring that they are retained in their correct order for refitting.

## OVERHAUL

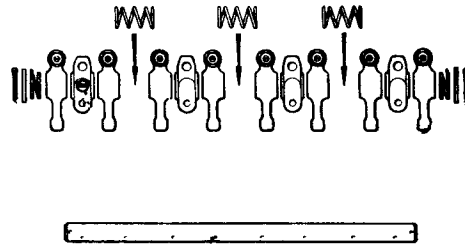

**Fig. 7 Rocker Shaft**

1. Remove split pin from each end of rocker shaft.
2. Suitably identify each rocker arm to its respective fitted position.
3. Remove plain washers, double coil spring washers, rocker arms, springs and pedestals from rocker shaft.  
**NOTE:** Rear pedestal is retained by a set screw located in the largest of two diametrically opposed holes in the rocker shaft.
4. Check rocker shaft for wear.
5. Check rocker to valve stem and adjusting screw to push rod contact faces for wear.
6. Check tappet adjusting screw threads and locknuts for damage.
7. Remove worn rocker arm bushes, noting their original fitted positions (See Fig.8)

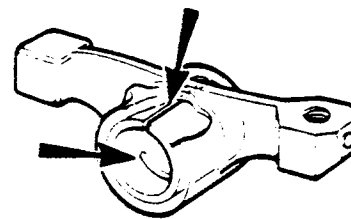
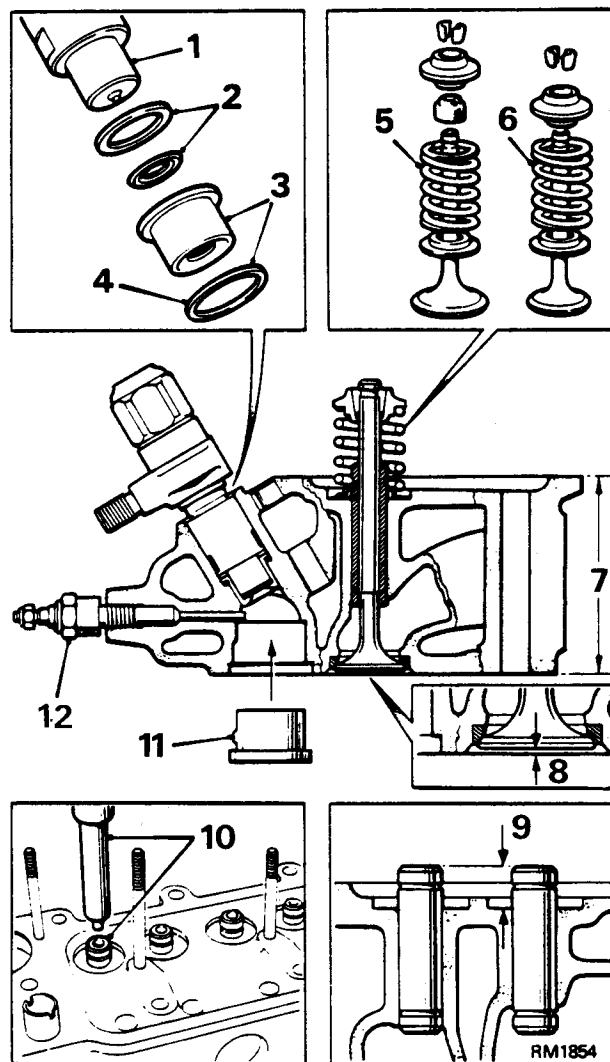

**Fig. 8 Fitted position of rocker shaft bush**

8. Press in new bushes ensuring that the bush joint and oil groove are in the positions shown. Drill a 1.95 (0.076in) (No. 48) drill hole in the bush via the hole in the rocker arm (See Fig.8). Burnish ream the bush to the dimension given in DATA.

9. Ensure that all traces of swarf are removed upon completion.
10. Re-assembly of the rocker shaft assembly is the reverse of operation 1 to 3, noting that all components must be lubricated and new split pins must be used.

### Cylinder Head



**Fig. 9 Cylinder head overhaul**

- |                           |                               |
|---------------------------|-------------------------------|
| 1. Injector               | 7. Cylinder head reface depth |
| 2. Sealing washers        | 8. Valve stand down dimension |
| 3. Heat shield            | 9. Valve guide protrusion     |
| 4. Sealing washer         | 10. Removing a valve guide    |
| 5. Inlet valve assembly   | 11. Combustion chamber insert |
| 6. Exhaust valve assembly | 12. Heater plug               |

1. Remove nuts and washers securing injectors.
2. Remove each injector in turn, discarding the copper and corrugated sealing washers.
3. Remove exhaust manifold and air inlet elbow. Discard the gasket.
4. Remove thermostat housing and thermostat. Discard the gasket.
5. Remove heater plugs.
6. Suitably mark the combustion chamber inserts to ensure refitment in their original locations. Remove inserts using a soft drift through the injector holes and gently tapping out.
7. Remove injector heat shields and sealing washers. Discard the sealing washers.
8. Remove valves and springs using 18G 106A (MS 1519A alternative)  
**NOTE:** 1. Keep valves in their correct order.  
2. Valve stem seals are fitted to the inlet valves only.
9. Check cylinder head face for warp and twist. Reface is necessary. DO NOT exceed figure given in DATA. ]  
**NOTE:** Combustion chamber inserts must be faced flush with cylinder head face.
10. Check valve guides for wear, see DATA. If worn, press guides out TOWARDS the valve seats using a suitable mandrel.
11. Using a suitable mandrel press new guides in FROM THE DIRECTION OF the valve seats, until they protrude by the amount stated in DATA. The dimension is obtained by measuring from the top of the valve guide to the bottom of the valve spring counterbore.
12. Ream new valve guides to the dimension given in DATA using MS150-8.5 or suitable alternative.
13. If necessary, recut valve seats using MS 204 (exhaust). MS 621 (inlet). MS 150-8.5 and MS 76.
14. Check valve springs against figures given in DATA and renew if necessary.
15. Grind in valves and check that valve stand down is within limits given in DATA.
16. Fit valves using new seals on inlet valve stems only. Use 18G 106A (MS 1519A Alternative) to compress valve springs.
17. Fit the injector heat shields using new sealing washers.
18. Using new corrugated steel sealing washers, fit them with their raised convex face uppermost (See Fig.10). Smear a new copper washer with grease and fit to the injector bore as shown. (Figure 10)

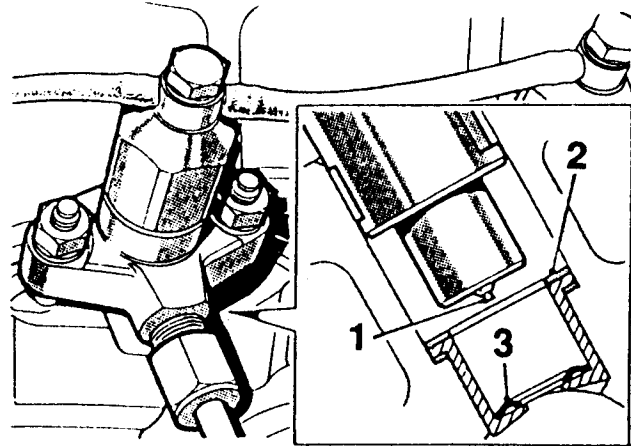

**Fig. 10 Injector seals**

1. Injector
  2. Copper washers
  3. Steel washers
19. Fit the injectors, spring washers and nuts. Tighten the nuts evenly to the correct torque.
  20. Fit the combustion chamber inserts noting the location detent is correctly positioned. Gently drift into position using a soft faced hammer if necessary. Alternatively, if slightly loose, retain the insert with a little grease. Ensure that they are flush with the cylinder head face.
  21. Smear the threads of the heater plugs with high temperature grease (PBC type) and fit the heater plugs, tightening to the correct torque.
  22. Using a new gasket, fit the thermostat and housing.
  23. Using a new gasket, fit the exhaust manifold and air inlet elbow.

### Timing Gears, Chain Tensioner and Chain

1. Examine gear teeth for wear: renew if necessary.
2. Check timing chain tensioner and damper chain contact faces for wear and scoring: renew if necessary.
3. Examine timing chain. Renew chain if links or rivets show signs of wear.

### Crankshaft and Bearings

1. Examine bearing shells, journals and thrust washers for wear, scoring or overheating: renew as necessary.
2. Check crankshaft journal diameters against figures given in DATA. **NOTE:** Crankshaft journals must not be reground, a service exchange crankshaft must be fitted.
3. Ensure that all oilways are clear.

## Crankshaft Spigot Bearing

1. Remove bearing using service tool FR581.
2. Drift in new bearing using 186 1333, ensuring the bearing seal is located to the outside.

## Pistons and Connecting Rods

**NOTE:** Keep pistons, rings and gudgeon pins with their respective connecting rods.

1. Remove piston rings.
2. Remove gudgeon pin circlips using 18G 1004, push out gudgeon pins.
3. Clean carbon from piston crown and ring grooves.
4. If piston crowns are pitted or the skirt is scored, a new piston must be fitted.
5. Check piston ring gaps in cylinder bores against figures given in DATA: renew rings as necessary.

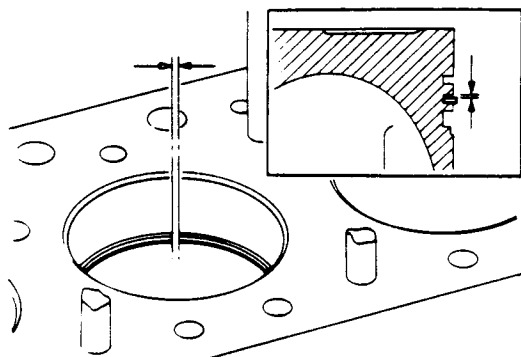

**Fig. 11** Checking piston ring gaps in cylinder bores

6. Check piston ring to groove clearance against figures given in DATA.
7. Check each gudgeon pin clearance in its respective connecting rod against figure given in DATA. If clearance is excessive, renew the connecting rod bush noting that:
  - \* Bush must be positioned with the hole and oil grooves towards top of connecting rod.
  - \* Bush must be finish reamed to the dimension given in DATA.
8. Check connecting rod alignment against figure given in DATA.
 

**NOTE:** Do not attempt to straighten a distorted connecting rod.
9. Fit pistons to connecting rods, using 18G 1004 to fit circlips.
 

**NOTE:** Ensure that the combustion cavities are towards the oil hole sides of the connecting rods.
10. Fit piston rings noting that:

- \* Fit oil control ring expander spring first ensuring that latch pin enters both ends of spring.
- \* Fit oil control ring with gap 180 degrees from the expander latch pin.
- \* Fit compression rings with word 'TOP' uppermost.
- \* Ensure piston ring gaps are evenly spaced and away from thrust side of piston.

## Oil Pump

1. Withdraw pump drive shaft. Remove cover bolts and cover.
 

**NOTE:** Pump cover is located on body with two dowels.
2. Clean all components.
3. Check pump for wear as shown and compare against figures given in DATA.
4. Assemble pump using clean engine oil on all components. Ensure that chamfered end of the outer rotor is fitted at the closed end of the pump body and that tang on drive shaft is located in slot in the inner rotor shaft.

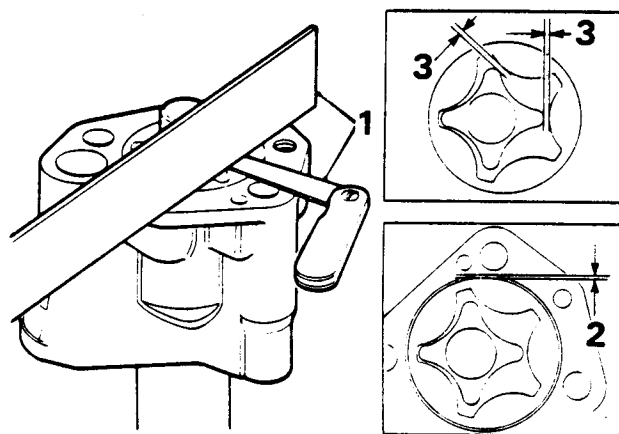

**Fig. 12** Checking oil pump dimensions

1. Checking inner and outer rotor end float
2. Checking out rotor to pump body diametrical clearance
3. Checking rotor lobe clearance

## Oil Pressure Relief Valve

1. Remove plug and washer. Recover spring and extract valve plunger using 18G 69, if available. If 18G 69 is not available, use a suitable piece of wooden dowel to locate inside the valve plunger to assist its extraction.

- If valve plunger is pitted it may be lapped in using grinding paste. Check spring length against figure in DATA and renew if necessary.

**NOTE:**

- \* Do not lap in plunger if engine is not dismantled. A new plunger must be fitted.
  - \* Ensure all traces of grinding paste are removed on completion.
- Refit valve plunger, spring, plug and new sealing washer.

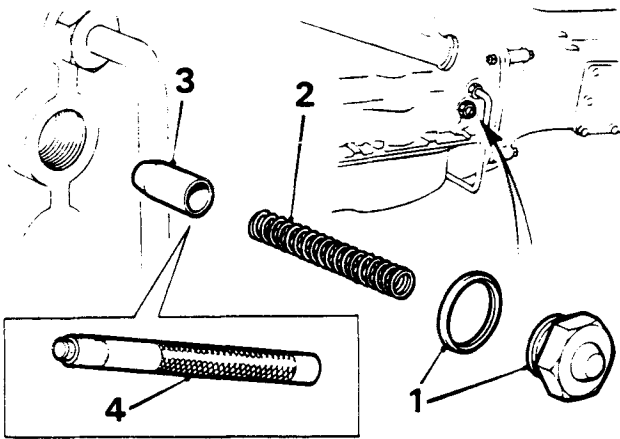

**Fig. 13. Oil pressure relief valve**

- Plug and washer
- Spring
- Valve plunger
- 18G 69

### Camshaft and Bearings

- Check camshaft for wear, see DATA, and renew if necessary.
  - Renew camshaft bearings if worn.
- NOTE:** When fitting new bearings ensure that oil holes in crankcase and bearings are in alignment.

### Tappets

- Remove the tappets and examine for excessive wear. Renew if necessary.
- Inspect the tappet bores in the cylinder block for wear and damage.
- If necessary, the tappet bores in the cylinder block may be bored oversize by 0.010in (0.254mm) from standard. If bored oversize, replacement oversize diameter tappets must be fitted.

## REASSEMBLY

- Ensure all components are thoroughly clean and in satisfactory serviceable condition prior to their assembly.
- During reassembly, components should be adequately lubricated with recommended engine oil.

### Tappets

- Support the cylinder block with its cylinder head gasket face resting on wooden blocks.
- Fit the tappets to the cylinder block with their open ends towards the top of the cylinder block.

### Camshaft

- Fit the camshaft
- Fit the fuel lift pump using a new gasket.

### Crankshaft

- Fit the upper main bearing shells to cylinder block.
  - Fit crankshaft thrust washers either side of centre main bearing ensuring that grooved sides are towards crankshaft. It may be useful to use petroleum jelly to hold them in place.
  - Fit lower main bearing shells to bearing caps and thrust washers to centre main bearing cap with grooved sides towards crankshaft.
  - Fit bearing caps noting that caps number 2 and 4 are stamped with their numbers and cap numbers 2, 3 and 4 are fitted with word 'FRONT' towards front of engine.
  - Using a straight edge, align the front and rear bearing caps with front and rear faces of cylinder block.
  - Tighten main bearing bolts from centre outwards to correct torque and using a Dial gauge against crankshaft rear flange check end float. Fit alternative thrust washers if necessary – see DATA – to achieve the correct figure.
- NOTE:** Both thrust washers must be of equal thickness.
- Fit the original front crankshaft timing gear shims and woodruff keys.

**Pistons and Connecting Rods**

12. Fit big end bearing shells to connecting rods.
13. Fit pistons; use 18G 55A to compress piston rings. Ensure piston ring gaps are correctly positioned.  
**NOTE:** Combustion cavities must face towards right hand side of engine, i.e. opposite side to the camshaft.
14. Fit big end bearing shells to bearing caps; refit caps in correct location and tighten cap nuts to correct torque. **NOTE:** If new pistons or connecting rods have been fitted check piston "stand proud". Rotate crankshaft and measure distance piston stands proud of cylinder block at T.D.C. If stand proud is outside limits given in DATA, fit an alternative piston. It is not necessary for pistons in an engine to be of the same height.

**Oil Pump**

15. Fit oil pump and drive shaft, using a new gasket. Ensure that drive shaft remains engaged with inner rotor shaft.

**Oil Sump**

16. Soak new cork sealing strips in oil and fit to front and rear main bearing caps.
17. Fit the sump using a new gasket. Tighten bolts from centre outwards to the correct torque.

**Front Mounting Plate**

18. Fit injection pump hub to mounting plate using a new gasket. Fit the fuel injection pump gear and locating halfplates to the hub. Fit the drive flange to the gear assembly using new tab washers.
19. Position mounting plate and new gasket on cylinder block. Locate it with chain tensioner securing screw and camshaft locating plate. Tighten the camshaft locating plate bolts to the correct torque.  
**NOTE:** Chain tensioner should be compressed and locked in retracted position.
20. Fit two front mounting bracket bolts.

**Camshaft End-float**

21. Fit camshaft gear using a new lock washer. Do not fully tighten nut at this stage.
22. Using a Dial gauge, check camshaft end-float against figure given in DATA. If necessary, fit new locating plate to achieve the correct figure.
23. Fit crankshaft gear.

**Crankshaft and Camshaft Gear Alignment**

24. Position the crankshaft by pulling to the front of the cylinder block. Place a straight edge across the crankshaft gear teeth and check the alignment of the crankshaft and camshaft gear teeth. The crankshaft gear must be between 0.000 to 0.005in (0.000 to 0.13mm) forward of the camshaft gear. Adjust the shim pack behind the crankshaft gear to achieve this condition.  
**NOTE:** In the event of the alignment between the crankshaft and camshaft gears being incorrect, premature wear of the timing chain and gears will occur.
25. Restrain the camshaft gear and torque tighten the retaining nut. Bend over the lockwasher.
26. Fit injection pump drive oil feed pipe.  
**NOTE:** Check that pipe is unobstructed by clearing it with an air line.
27. Fit timing chain damper.
28. Insert a 5.5mm (7/32in) diameter peg through hole in injection pump gear (see Fig.4) to enter hole in front mounting plate.
29. Align timing marks on crankshaft and camshaft gears. (See Fig.4).
30. Compress timing chain tensioner and rotate centre pin through 180 degrees.  
**NOTE:** Tensioner body, not tensioner pad, must contact front mounting plate.
31. Fit timing chain and position the idler gear less hub. Adjust chain such that idler gear hub may be fitted without there being any slack chain between idler gear, camshaft gear and injection pump gear.
32. Fit idler gear hub ensuring that it is located on the roll pin; fit retaining bolt.
33. Rotate chain tensioner centre pin through 180 degrees to release tensioner.
34. Check that timing marks are still aligned and remove peg from injection pump gear.
35. Fit crankshaft oil thrower with mark 'F' facing towards pulley (Convex face outwards).
36. Fit fuel injection pump. (See section 'Fuel Injection Pump-Refit').

**Timing Cover and Gearbox Adaptor Plate**

37. Fit a new oil seal to timing cover using 18G 134 and 18G 134BD.
38. Lubricate oil seal and fit cover using a new gasket.
39. Centralise timing cover using the crankshaft pulley and fit retaining bolts in the locations shown in Fig.14.

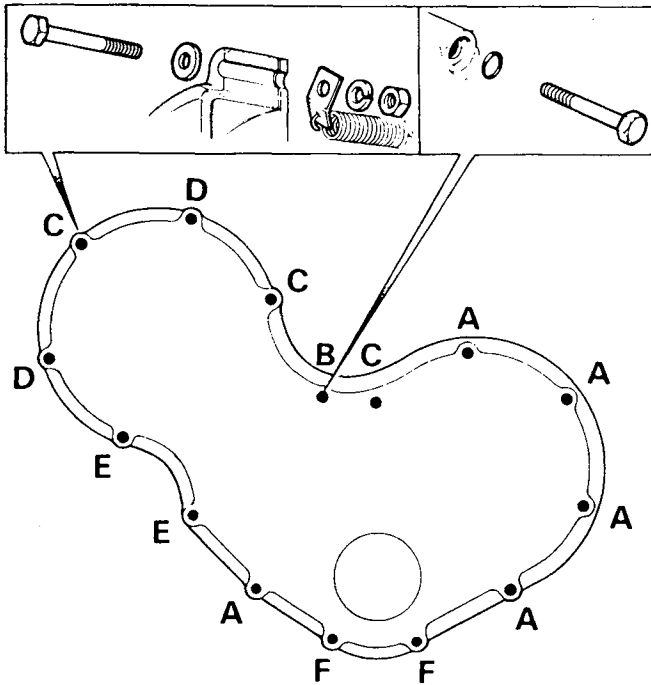
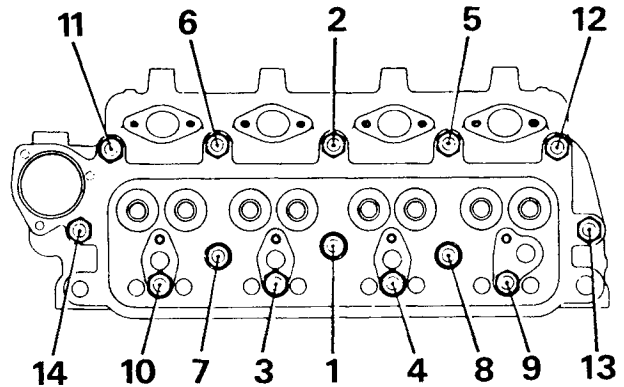

**Fig. 14 - fitting timing cover bolts.**

- | Position | Bolt Size                                       |
|----------|---|
| A        | 7.9 x 44.5mm (5/16 x 1 3/4in)                   |
| B        | 7.9 x 50.0mm (5/16 x 2in)                       |
|          | <b>NOTE:</b> An 'O' ring is fitted on this bolt |
| C        | 7.9 x 50.0mm (5/16 x 2in)                       |
| D        | 7.9 x 57.0mm (5/16 x 2 1/4in)                   |
| E        | 6.35 x 44.5mm (1/4 x 1 3/4in)                   |
| F        | 6.35 x 31.7mm (1/4 x 1 1/4in)                   |
40. Fit crankshaft pulley. Apply Loctite 270 to the crankshaft pulley bolt and fit it.
  41. Tighten bolt to figure given in DATA.
  42. Fit the water pump using a new gasket.
  43. Remove oil seal from gearbox adaptor plate.
  44. Using 18G 134 and 18G 134CQ fit new oil seal.  
**NOTE:** When fitted, seal must be flush with rear face of adaptor plate.
  45. Lubricate the seal and fit adaptor plate using 18G 1108 over the crankshaft to protect the seal. Use new gaskets. Locate the oil seal retainer.  
**NOTE:** Two longest securing bolts are located at top of adaptor plate.
  46. Fit flywheel using a new lockwasher. Tighten the bolts to the correct torque and bend back the lockwasher.
  47. Fit clutch. Centralise clutch using 18G 1195.

## Cylinder Head

48. Fit cylinder head, use a new gasket, word 'TOP' uppermost.  
**NOTE:** Ensure combustion chamber inserts are not displaced.
49. Fit push rods, shims beneath centre pedestals.
50. Fit the rocker shaft, with the locking plate on rear pedestal.



**Fig. 15 Cylinder head nut tightening sequence.**

51. Tighten cylinder head nuts in sequence shown to the correct torque figure. Use 18G 694A or suitable crowfoot socket to tighten the three nuts beneath the rocker shaft.  
**NOTE:** Tighten the nuts in the sequence shown in Fig.15.
52. Tighten the rocker pedestal nuts.
53. Adjust tappet clearances - see DATA.
54. Fit rocker cover: use a new gasket.
55. Fit dipstick tube to cylinder head.
56. Fit new oil filter element and fill with clean engine oil.
57. Fill the cooling system with 33 1/3% antifreeze solution.
58. Fit vacuum pump bracket and pump, fit alternator: tension drive belts.
59. Fit oil feed pipe, heater plug harness, fuel spill and injector pipes.
60. Bleed the fuel system.
61. Run engine and check for leaks.
62. Road test vehicle and allow engine to cool.
63. Re-torque cylinder head nuts. Adjust tappet clearances - see DATA.
64. Fit rocker cover.



## FUEL SYSTEM

### DATA

#### Fuel Injection pump

Type C.A.V.DPA 3247F401  
Injection timing 18 degrees B.T.D.C.  
Roller to roller dimension 50.30mm

#### Fuel lift pump

AC Mechanical

#### Fuel injectors

C.A.V. Pintaux

Nozzle type BDN.OSPC.6651  
Nozzle holder type BKB.35SD.5188  
Opening pressure 135 atmospheres  
Auxiliary hole diameter 0.2mm  
Needle lift 0.70 to 0.75mm  
Nozzle seat angle 59 degrees  
Valve seat angle 60 degrees

#### Main fuel filter

C.A.V.

Type FS 583 6B 130

#### Idle speed

650 to 750 rev/min

#### Flight speed

5000 rev/min

## SPECIAL TOOLS

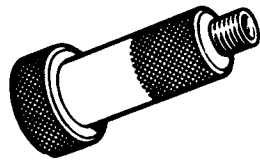

18G 109E Nozzle holder

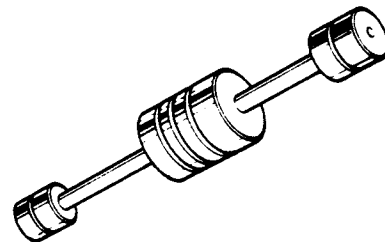

18G 284 Impulse extactor

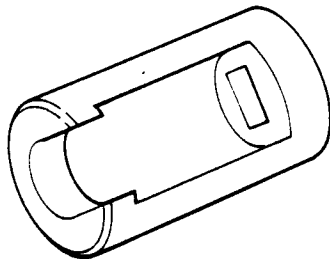

18G 210 Injector nozzle nut socket

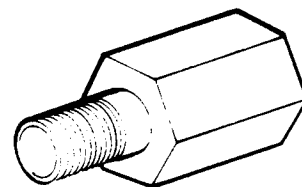

18G 284P Removal adaptor

**DIAGNOSTIC TOOLS**

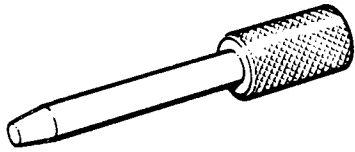

AMK 9990 Timing pin

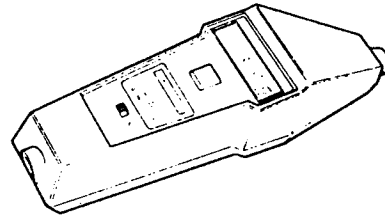

DX 800 Optical tachometer

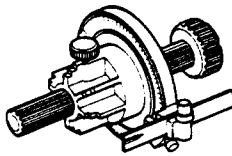

MS67 A Pump Timing Gauge

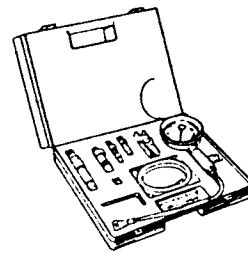

DX 510 Compression tester

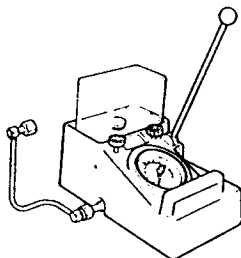

111 (alt. DX 710, Minitest)  
Injector analyser

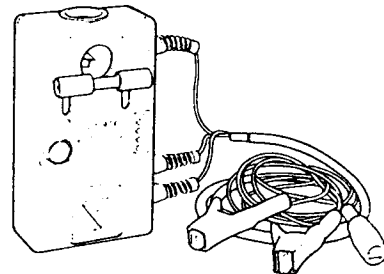

DX 900 Glow plug tester

**TORQUE WRENCH SETTINGS**

	Nm	lbf.ft	kgf.m.
Fuel lift pump nuts	16	12	1.7
Injector nozzle nut	68	50	6.9
Injection pump nuts	24	18	2.5
Injector nuts	16	12	1.7

## FUEL SYSTEM LAYOUT

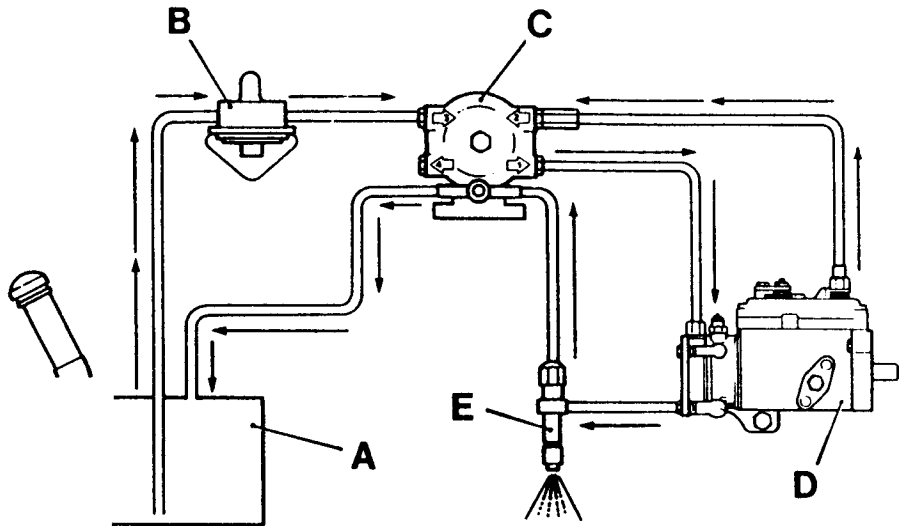

**Fig 1. Fuel system layout**

- |              |                   |
|--------------|-------------------|
| A. Fuel tank | D. Injection pump |
| B. Lift pump | E. Injector       |
| C. Filter    |                   |

## OPERATION

The mechanical fuel lift pump 'B' operated by a lobe on the camshaft, draws fuel from the fuel tank 'A'. This fuel enters the filter 'C' at connection No 3 in the head, passes through the filter element and out through connection No. 1. The filtered fuel is delivered to the injection pump 'D' at approximately  $0.42 \text{ kg/cm}^2$  ( $6 \text{ lb/in}^2$ ) and this pressure is boosted inside the unit by its transfer pump to approximately  $2.5 \text{ kg/cm}^2$  ( $35 \text{ lb/in}^2$ ). This pressure ensures that the fuel circulates inside the injection pump to lubricate all the working parts.

The fuel used to lubricate the pump returns to the filter head at connection No2 via a one-way valve.

A very much higher fuel pressure is required from the injection pump to open the injectors 'E', which occurs at 135-140 atmospheres.

The pump delivers fuel to the injectors in metered quantities dependant on throttle position and engine speed.

Excess fuel from the injectors passes along the spill return to a banjo connection on the top of the filter 'C'; and from the same connection excess fuel in the system returns to the fuel tank 'A'.

### Fuel Filter

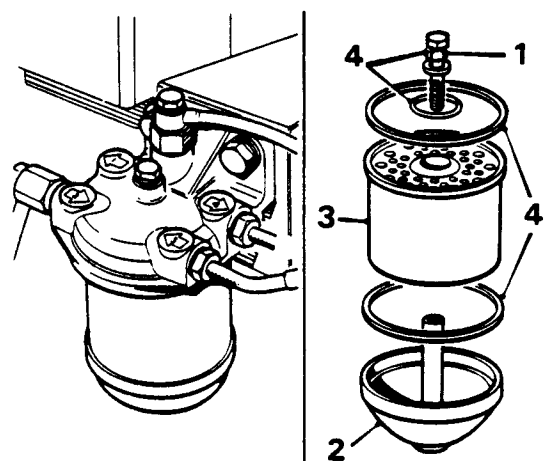

**Fig. 2 Fuel filter element renewal**

- |                |                   |
|----------------|-------------------|
| 1. Centre bolt | 3. Filter element |
| 2. Filter base | 4. Sealing rings  |

## Renew Element

1. If a draincock is fitted to the filter base, drain the fuel from the filter into a suitable container. Tighten the drain cock.
2. Remove centre bolt and detach filter base.
3. Remove element and sealing rings.
4. Smear new sealing rings with clean fuel. Position them in filter base and head.
5. Fit element and bowl.
6. Bleed the fuel system as described in "Bleeding the Fuel System".

## Flight Speed

(Engine maximum governed speed)

### Check and Adjust

1. Run engine until it reaches normal operating temperature. Stop the engine
2. Ensure that accelerator pedal and throttle cable travel is not restricted, and that the pump linkage moves to the full throttle position when the accelerator pedal is fully depressed. Rectify if necessary.
3. Start the engine and depress the accelerator pedal fully.
4. Using a suitable tachometer, check the maximum no-load speed (flight speed) of the engine and compare with the figure given in DATA.
5. If the flight speed is incorrectly set, remove the tamper-proofing cover from the maximum speed stop screw. Adjust the screw until correct running speed is obtained. Tighten the locknut on completion.
6. Refit the tamper proofing cover, new lockwire and seal.

### Engine Idle Speed and Anti-stall Setting.

**NOTE:** If the engine idle speed is adjusted, the anti-stall setting must also be re-set.

1. Ensure the accelerator pedal, cable and fuel injection pump throttle lever operate freely and are able to return fully, un-assisted.
2. Ensure the engine is at normal operating temperature.
3. Remove the wire locking from the anti-stall screw. Slacken the locknut and unscrew the anti-stall screw three full turns.
4. Using a suitable tachometer, with the engine running at idle speed, check the engine idle speed and compare with the figure given in data.

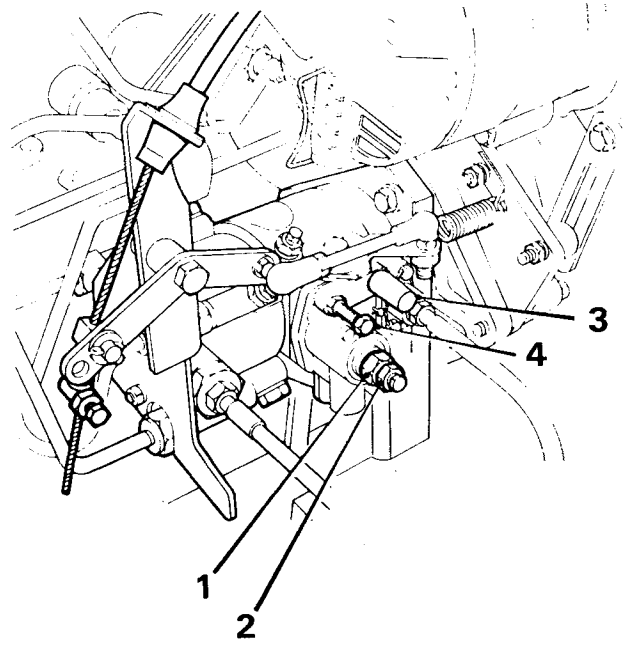

**Fig. 3 Engine Idle Speed Adjustment**

1. Anti-stall screw locknut
2. Anti-stall screw
3. Maximum speed stop screw
4. Idle speed stop screw
5. If the idle speed is incorrect, adjust the idle speed stop screw until idle speed is correct. Tighten the locknut on completion.
6. Screw in the anti-stall screw until engine idle speed is just affected, then unscrew anti-stall screw TWO FLATS. Tighten the locknut on completion.
7. Allow engine to idle and check the exhaust. If smoking is excessive with engine at normal operating temperature, open the throttle. If exhaust smoke does not reduce, refer to fault finding.
8. Wire lock the anti-stall screw and refit the tamper-proofing seal.

## BLEEDING THE FUEL SYSTEM

**WARNING:** Do not attempt to bleed fuel system by towing the vehicle in gear; damage to fuel injection pump will result.

**NOTE:** After renewing fuel filter element it will only be necessary to carry out the first two steps below providing engine has not been turned.

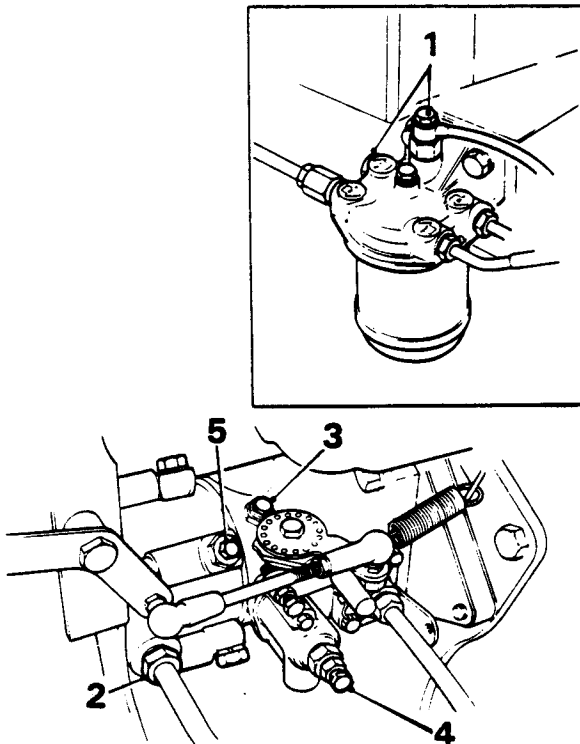

**Fig. 4 Fuel System Bleeding**

1. Fuel filter bleed points
  2. Injection pipe union
  3. Pump body bleed screw
  4. Governor housing bleed screw
  5. High pressure banjo bolt bleed screw
1. Loosen the blanking plug on the fuel filter head and prime the fuel system by operating the fuel lift pump priming lever. Continue to prime the system until air free fuel flows from the plug. Tighten the plug.
  2. Loosen the fuel spill return union on the filter head and prime the fuel system until air free fuel flows from the union. Tighten the union.
  - 3 a) If the fuel injection pump has an electrically operated fuel cut off, switch on the ignition.

- b) If the fuel injection pump has a cable operated fuel cut off, ensure it is in the fully returned (off) position.
4. Loosen the bleed screw fitted to the fuel injection pump body (See Fig.4), and prime the fuel system until air free fuel flows from the bleed screw. Tighten the bleed screw.
5. Whilst restraining the anti-stall screw from turning, loosen the governor housing bleed screw. Prime the fuel system until air free fuel flows from the bleed screw. Tighten the bleed screw whilst restraining the anti-stall screw from turning.
6. a) If the fuel injection pump has an electrically operated fuel cut off, switch off the ignition.  
b) If the fuel injection pump has a cable operated fuel cut off, pull the cable to the fully out (stop) position.
7. Turn the crankshaft clockwise one complete revolution.
8. Repeat operations 3 to 5.
9. Loosen the injector pipe unions at the injector ends and loosen the high pressure banjo bolt bleed screw (see Fig.4).
10. Fully depress the accelerator pedal and crank the engine until air free fuel flows from the high pressure banjo bolt bleed screw. Tighten the bleed screw.  
**CAUTION:** Crank the engine for no longer than ten seconds. Allow ten seconds before operating the starter again.
11. Keep the accelerator pedal fully depressed and crank the engine until fuel is seen at the injector pipe injector unions. Tighten the unions.  
**CAUTION:** Crank the engine for no longer than ten seconds. Allow ten seconds before operating the starter again.
12. With the accelerator pedal fully depressed, crank the engine until it starts.  
**CAUTION:** Crank the engine for no longer than ten seconds. Allow ten seconds before operating the starter again.
13. Ensure the engine runs satisfactorily and there are no leaks in the fuel system.

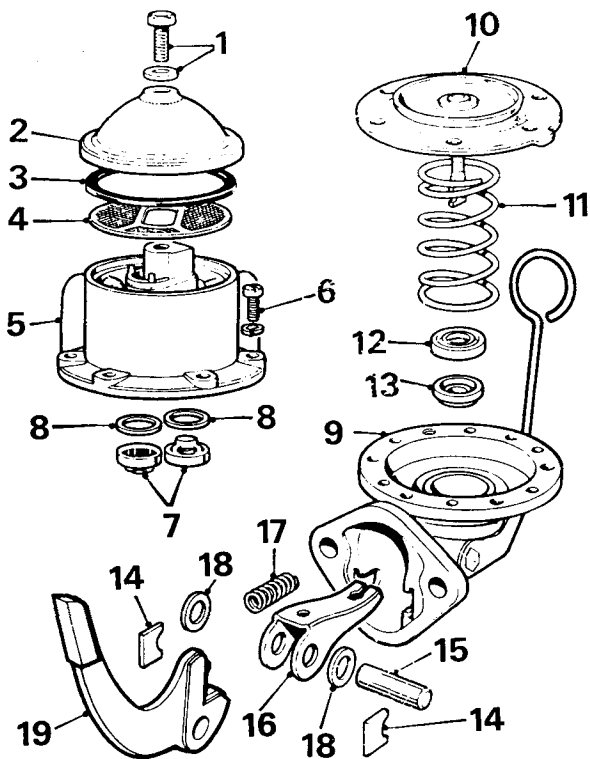

**Fig. 5 Components of Fuel Lift Pump**

- |                        |                     |
|------------------------|---------------------|
| 1. Cover securing bolt | 11. Spring          |
| 2. Cover               | 12. Seal retainer   |
| 3. Sealing ring        | 13. Seal            |
| 4. Filter              | 14. Collets         |
| 5. Pump body           | 15. Rocker shaft    |
| 6. Securing screw      | 16. Rocker arm      |
| 7. Valves              | 17. Spring          |
| 8. Sealing washers     | 18. Plain washers   |
| 9. Pump base           | 19. Operating lever |
| 10. Diaphragm          |                     |

### Dismantling

1. Remove fuel lift pump.
2. Remove pump cover, sealing ring and filter.
3. Scribe an alignment mark across pump body joint flanges.
4. Remove pump body securing screws and separate pump body from base.
5. Note fitted position of valves and lever valves out of recess. Recover sealing washers.
6. Rotate diaphragm through 90 degrees and withdraw plunger, spring, seal retainer and seal.
7. Remove rocker shaft collets, rocker shaft, operating lever, rocker arm spring and plain washers.

### Reassemble

8. Fit rocker arm, operating lever, rocker shaft, spring, plain washers and collets.  
**NOTE:** Spring must locate over 'pip' on operating lever.
9. Fit a new seal and retainer in pump base.
10. Fit diaphragm and spring ensuring rod engages fully with rocker arm.  
**NOTE:** If spring is renewed colour coding of replacement must be same as original.
11. Fit valves sealing washers and valves; stake valves in position.
12. Fit pump body to base.
13. Fit filter, new sealing ring and pump cover. Do not overtighten, cover securing bolt.
14. Using a new gasket, refit fuel pump ensuring operating lever is correctly located on camshaft.
15. Bleed fuel system as described in "Bleeding the fuel system".

### Fuel Injection Pump

#### Remove

1. Disconnect battery, negative terminal first.
- 2 either
  - a) Disconnect the electrical cable from the electrical fuel cut off solenoid.
  - or
  - b) Disconnect the cable from the mechanical stop control.
3. Disconnect accelerator linkage cable(s).
4. Disconnect fuel return and supply pipes from pump.
5. Disconnect high pressure pipes from pump and injectors.
6. Release throttle lever return spring.
7. Remove retaining nuts and washers.
8. Remove the pump and recover the torsion bar. Discard the gasket.

#### Refit

9. Rotate crankshaft until master spline in timing gear is at 12 o'clock position.
10. Insert timing pin AMK 9990 into timing hole in gearbox adaptor plate.  
**NOTE:** Hole is situated below sump flange on right hand side of engine.
11. Maintain light pressure on the timing pin and rotate the crankshaft clockwise until pin engages with hole in flywheel. The master spline should now be at the 8 o'clock position when viewed from the rear.

12. Remove timing pin, DO NOT rotate engine.
13. Position pump drive shaft so that master spline on shaft aligns with master spline on pump hub. Fit a new gasket on pump mounting studs.

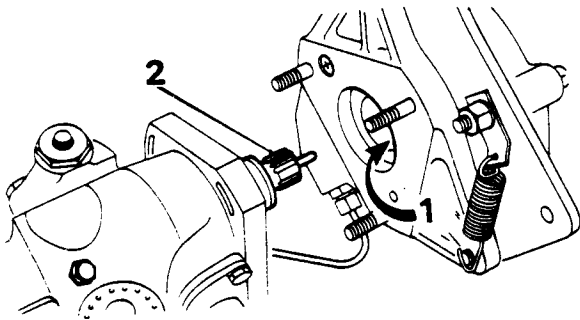

**Fig. 6 Fitting the Fuel Injection Pump**

1. Pump drive hub
2. Injection pump master spline
14. Fit torsion bar to pump drive hub.
15. Push the pump into position until the pump body abuts the pump mounting flange.
16. Fit the spring washers and nuts. Tighten the nuts progressively to ensure the pump is fitted squarely against the flange.
17. Before finally tightening the securing nuts, align the scribed timing mark on the pump flange to the scribed mark or pointer on the pump mounting flange.
18. Tighten the pump securing nuts to the correct torque.
19. Fit throttle return spring and high pressure pipes.
20. Connect fuel return and supply pipes, accelerator cable(s), stop solenoid cable or mechanical stop control cable, and the battery.
21. Bleed the fuel system as described in "Bleeding the fuel system".

### Fuel Injection Pump Timing

In the event of the fuel injection pump timing marks being incorrect, the following procedure must be carried out to re-set the timing mark position.

1. Remove the fuel injection pump (see "Fuel Injection Pump - Remove").
2. Rotate crankshaft until master spline in timing gear is at 12 o'clock position.
3. Insert timing pin AMK 9990 into timing hole in gearbox adaptor plate.  
**NOTE:** Hole is situated below sump flange on right hand side of engine.

4. Maintain light pressure on the timing pin and rotate the crankshaft clockwise until pin engages with hole in flywheel. The master spline should now be at the 8 o'clock position when viewed from the rear.

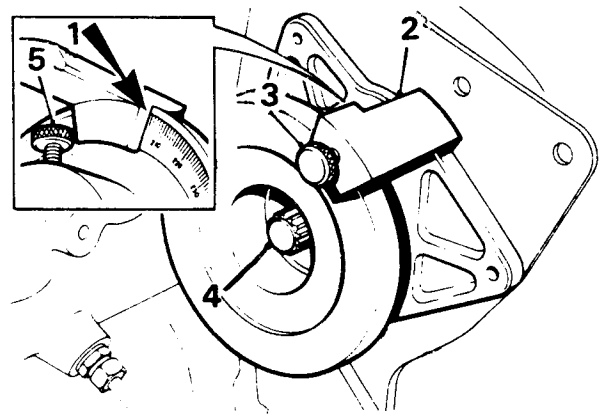

**Fig. 7 Setting fuel Injection pump timing mark using MS67A**

1. 204 degree position
2. Long scribing guide
3. Long scribing guide knurled lock screw
4. Centre bar
5. Centre bar knurled lock screw
5. Assemble the long scribing guide of MS67A to the tool body, set it on the 204° position and lock it with the knurled screw.
6. Locate the assembled tool on the engine, engaging the injection pump drive splines.
7. Slide the body of the tool along the centre bar until the body engages the injection pump gear drive hub. Lock the centre bar with the knurled screw.
8. Apply pressure in a clockwise direction (viewed from the rear) and check that the scribed timing mark or adjustable pointer on the drive gear hub lines up with the scribing guide of the tool.
9. If necessary, delete the old mark and scribe a new mark or adjust the position of the adjustable pointer to align with the scribing guide of the tool.
10. Remove MS67A.
11. Refit the fuel injection pump (see Fuel Injection Pump – Refit).

## INJECTORS

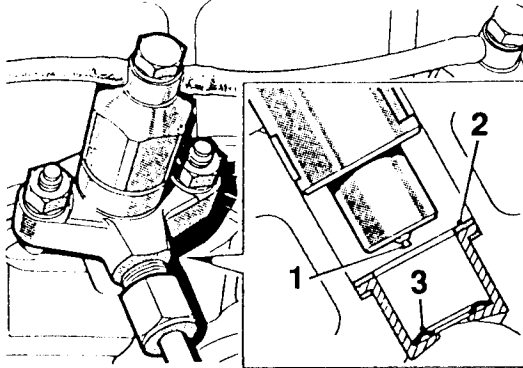

**Fig. 8 Injector seals**

1. Injector
2. Copper washers
3. Steel washers

### Remove

1. Slacken the injector feed pipes at the injection pump and disconnect the pipes at the injectors.
2. Disconnect the spill rail from the injectors.
3. Remove the nuts and washers securing the injectors and withdraw the injectors.
4. Remove the two sealing washers from each injector position.

### Overhaul

5. Remove the cap nut and sealing washer.
6. Unscrew the pressure adjusting screw and withdraw the pressure spring and valve spindle.
7. Unscrew the nozzle nut using 18G 210, and withdraw the nozzle valve and body.  
**NOTE: Retain the components of each injector in sets, do not interchange parts.**
8. Soak the components in Shell Calibration Fluid to loosen carbon deposits, then carefully clean the nozzle and valve. Reverse flush the nozzle using tool 18G 109E.
9. Examine all components for excessive wear or damage; renew any defective parts.
10. Rebuild the injector in the reverse procedure to the dismantling.
11. Test and adjust the injector as follows:-  
**WARNING: The Injection nozzle must not be allowed to point towards the operator when spraying, and the hands must never be allowed to contact the spray which has great penetrating force.**

- a. Fit the injector to the test equipment, tool 111.
- b. Adjust the injector to open at 135 atm. by screwing the pressure adjusting screw clockwise to increase pressure or anti-clockwise to reduce pressure. Check that the auxiliary and main spray patterns are satisfactory.
- c. Increase the injector pressure to open at 160-170 atm. Carry out a timed pressure drop test from 150 atm down to 100 atm. This should be not less than 5 seconds for the original nozzle, or 7 seconds for a new nozzle, and not more than 36 seconds for either with oil at 10° to 21°C (50° to 70°F).
- d. Readjust the injector to open at 135 atm, and allow the pressure to return to zero. Wipe the bottom face of the injector nozzle, then slowly raise the pressure to 125 atm and examine the bottom face. A slight dampness is permissible, but any blob formation or dripping indicates a badly seated valve which must be rectified.

### Refit

12. Using new corrugated steel sealing washers, fit them with their raised convex face uppermost. (See Fig. 8).
13. Apply a light coating of grease to the copper sealing washer and position it in the injector bore. Fit the injector, secure with the nuts and washers and progressively tighten the nuts to the correct torque.
14. Refit the spill rails and injector feed pipes.
15. Start the engine and check for leaks.



**INCORRECT IDLING AND MAX SPEEDS**  
**LOSS OF POWER POOR CONSUMPTION**  
**UNEVEN RUNNING – MISFIRING**  
**EXCESSIVE EXHAUST**  
**DIFFICULT STARTING**

**FUEL INJECTION EQUIPMENT**  
**FAULT DIAGNOSIS**

SYMPTOM				CAUSE	CHECK
			1→	1 No fuel	1 Fuel level
			2→	2 Stop control	2 In run position and linkage free
			3→	3 Starting procedure	3 Is it correct
4→	4→		4→	4 Air in system	4 That system is vented and all joints and unions air tight
5→	5→		5→	5 Fuel restriction	5 Filters and pipes clear
			6→	6 Fuel contamination	6 That fuel is free of water, dirt, ice and wax
			7→	7 Cranking speed	7 Correct Lub. oil. Battery, starter and cable connections
			8→	8 Starting aid	8 Correct functioning. Fuel supply and electrical connections
	9→	9→	9→	9 Injection timing	9 Pump to engine timing
10→	10→		10→	10 Feed pump	10 Pressure
11→	11→		11→	11 Blocked return pipe	11 DPA back leak, return to tank and filter vents are free
12→	12→	12→	12→	12 Poor compression	12 Cyl. comp. Air intake clear. Injector seats. Valve clearances & timing
			13→	13 Exhaust system	13 Unrestricted
14→	14→	14→	14→	14 Fuel atomisation	14 Injectors – type, setting, condition, sealing and evenly tightened down
			15→	15 Fuel tank vent	15 Vent unrestricted
			16→	16 Firing order	16 HP pipes fitted in correct order
			17→	17 HP pipe restriction	17 HP pipe bores not kinked or reduced at nipples
18→	18→	18→	18→	18 HP leaks	18 HP pipe joint tightness
	19→			19 LP leaks	19 Fuel pipes for leaks
20→				20 Idling speed incorrect	20 Engine idling speed setting
21→	21→			21 Max speed incorrect	21 Engine maximum no load setting
22→	22→			22 Accelerator linkage	22 Lever loose on pump, reaches stops. Linkage wear. Pedal stop setting
			23→	23 Engine mounting	23 Mountings are tight
			24→	24 Vibration	24 Vibration not transmitted from elsewhere
25→				25 Overloading	25 Vehicle payload
25→				26 Brakes	26 Brakes not binding
			27→	27 F I pump mounting	27 F I pump drive and mounting bolts tight
28→	28→	28→	28→	28 F I pump	28 If all else fails remove F I pump and send for specialist check

**CYLINDER KNOCK – UNEVEN RUNNING – MISFIRE  
LOSS OF POWER EXCESSIVE CONSUMPTION  
ENGINE OVERHEATING  
BLACK SMOKE  
POOR STARTING**

**INJECTOR  
FAULT DIAGNOSIS**

SYMPTOM				CAUSE	CHECK
+	+			Injector not sealing in cylinder head	For cleanliness and sealing washers if specified
+	+	+	+	Two sealing washers under injector	Number of washers and if specified
+	+			High pressure pipe joint leaks	Pipe unions for leaks
	+			Back leak pipe joint leaks	Unions for leaks
+				High pressure pipe restricted	High pressure pipe bores
+	+	+	+	Injector sticking	Fixing nuts or bolts are accurately torqued with correct washer
+	+	+	+	Incorrect injectors fitted	Manufacturer's specification
+	+	+	+	Injector faulty	Check injector on a nozzle setting outfit

**BACK LEAKAGE  
OPENING PRESSURE  
ATOMISATION**

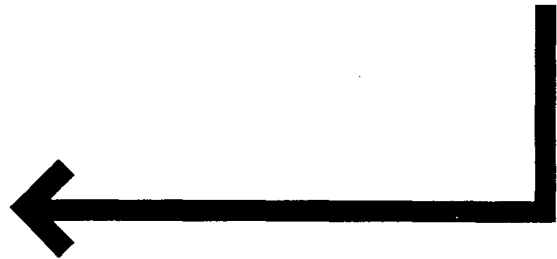

**SEAT TIGHTNESS**

SYMPTOM				CAUSE	CHECK
+				Pressure face leak	Nozzle cap nut torque and pressure faces clean and undamaged
+				Nozzle valve scored or having excessive clearance	Valve stem and nozzle body visually
	+	+		Incorrect setting	Opening pressure and reset if necessary
	+	+	+	Nozzle siezed or sticking	For foreign matter, distortion or damage
	+	+		Spray holes blocked	Holes are free of carbon
+	+	+	+	Valve not seating	Nozzle valve and body for carbon pitting or damage
	+	+		Broken or distorted spring	Spring visually and replace if necessary
	+	+		Auxilliary hole blocked	Hole is free of carbon
		+		Pintle broken or damaged	Spindle ends for wear and replace if necessary
	+	+	+	Nozzle cap nut overtightened	Cap nut torque. See setting overleaf

**REMOVING INJECTORS** Always ensure that injectors are not knocked during removal particularly on pintaux nozzles as the valve tips can easily be damaged. Impact extractors are available from your CAV agent and are very effective on stubborn injectors.

**FITTING INJECTORS** Ensure injector/cylinder head bore and seat are clean. Check manufacturer's specification is observed for fitment of sealing washer and heat shield. Tighten fixing bolts or nuts evenly to the correct torque.

**IF NOZZLE BODY OR VALVE IS WORN OR DAMAGED THE NOZZLE MUST BE REPLACED OR SENT FOR SPECIALIST REPAIR.**

## HEATER PLUG SYSTEM

### Introduction

Since the K2 model launch, two systems have been used on vehicles fitted with the 1.8 Diesel engine. They are not interchangeable with one another.

### K2 VEHICLES PRIOR TO VIN 258340

#### Starting Procedure Engine Cold

Turn the key to position 'II' to switch on the heater plugs; the orange warning light will glow until the heater plugs are hot.

The time lapse before the heater plugs are hot will normally be 10-15 second.

When the heater plugs are hot, operate the starter. Depress the accelerator pedal fully.

Check that the red no charge and oil pressure warning lights are extinguished when the engine is running.

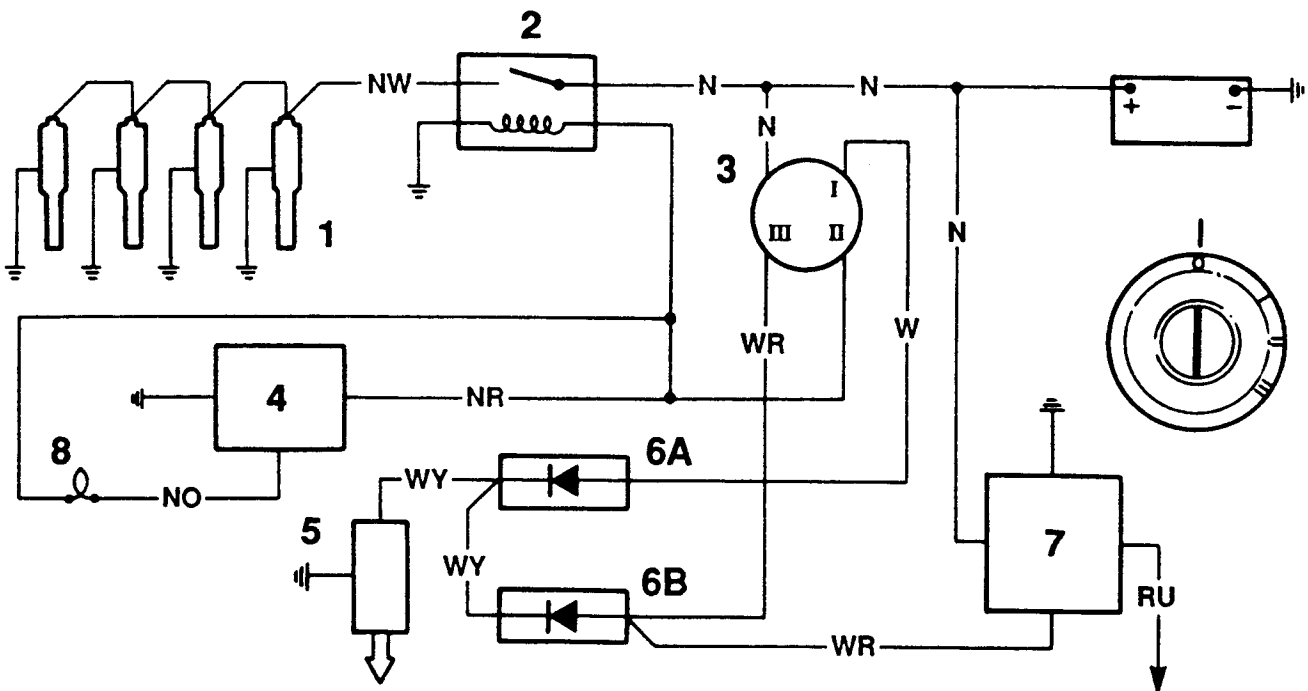

Fig. 1 Heater plug circuit.

- 1 – Heater plugs
- 2 – Heater plug relay
- 3 – Ignition switch
- 4 – Heater plug warning light unit
- 5 – Fuel cut-off solenoid
- 6 – Blocking diodes
- 7 – Starter relay
- 8 – Heater plug dash light

#### Wiring colour codes

- N – Brown
- NO – Brown/Orange
- NR – Brown/Red
- NU – Brown/Blue
- NW – Brown/White
- W – White
- WR – White/Red
- WY – White/Yellow

## System Components

The components of the heater plug system are as follows:

### 1. The Heater Plugs

The heater plugs are located in the engine cylinder head and they require a time of approximately 15 seconds to reach normal temperature. As will be seen from the wiring diagram, the heater plugs are connected in parallel, so if one heater plug fails open circuit the other three will continue to operate.

### 2. Heater Plug Relay.

A "Black Box" located on the near side front bulkhead, having four wires attached to it. (see wiring diagram).

This relay is switched by the driver operation of the ignition switch key, and, when energised, switches on the heater plugs.

### 3. Ignition Switch

Doubling as the steering column lock and "Ignition" switch, this unit is key operated by the driver.

The switch has four positions as follows:-

#### POSITION 0

Steering locked - All ancillary circuits switched off.

#### POSITION 1

Steering unlocked - Normal engine run position - Auxiliary circuits switched on.

#### POSITION II

Key must be held against spring loading - in this position heater plugs are on at all times.

#### POSITION III

Key must be held against spring loading - Engine start position - the key, when released will return to position I.

### 4. Heater Plug Warning Light Unit

A "Black Box" located on the nearside front bulkhead, having three wires attached to it. (see wiring diagram).

This unit is basically a timer to indicate to the driver when the heater plugs are hot enough to enable the engine to start. It does this by illuminating the heater plug dash light when the ignition switch is turned to position II. Holding the key in this position, after approximately fifteen seconds, the heater plug dash light will be switched off by the heater plug warning light unit. The heater plugs will not be switched off by this unit, only the dash light, so if the ignition switch is held in position II after the dash light has gone out, the heater plugs will still be operating.

### 5. Fuel Cut-off Solenoid

The fuel cut-off solenoid is situated in the transfer pump housing of the fuel injection pump, the engine can run only when the unit is energised. When the ignition switch is turned off, spring pressure returns a plunger, which blocks the fuel passage between the fuel injection pump transfer pump and the metering valve, thereby stopping the engine.

### 6. Blocking Diodes

Two diodes, shown on the wiring diagram at 6A and 6B are taped to the wiring harness below the heater plug relay and heater plug warning light unit. One diode, 6A, is used to energise the fuel cut-off solenoid in ignition switch positions I and II, the other diode, 6B, is used to energise the fuel cut-off solenoid whilst the engine is cranking.

### 7. Starter Relay

The starter relay is located on the nearside bulkhead between the heater plug relay and heater plug warning light unit. The starter relay is a bright anodised colour.

It is energised when the ignition switch is in position III, this relay in turn energises the starter motor solenoid.

### 8. Heater Plug Dash Light

The heater plug dash light is located in the fascia, and is operated by the heater plug warning light unit. It is fitted with an orange lens with a coiled wire symbol.

**System Operation**

A brown wire, permanent live feed, goes from the vehicle battery positive terminal to the ignition switch, heater plug relay and starter relay.

The following diagrams will assist in understanding the system operation. The heavy lines indicate live wires.

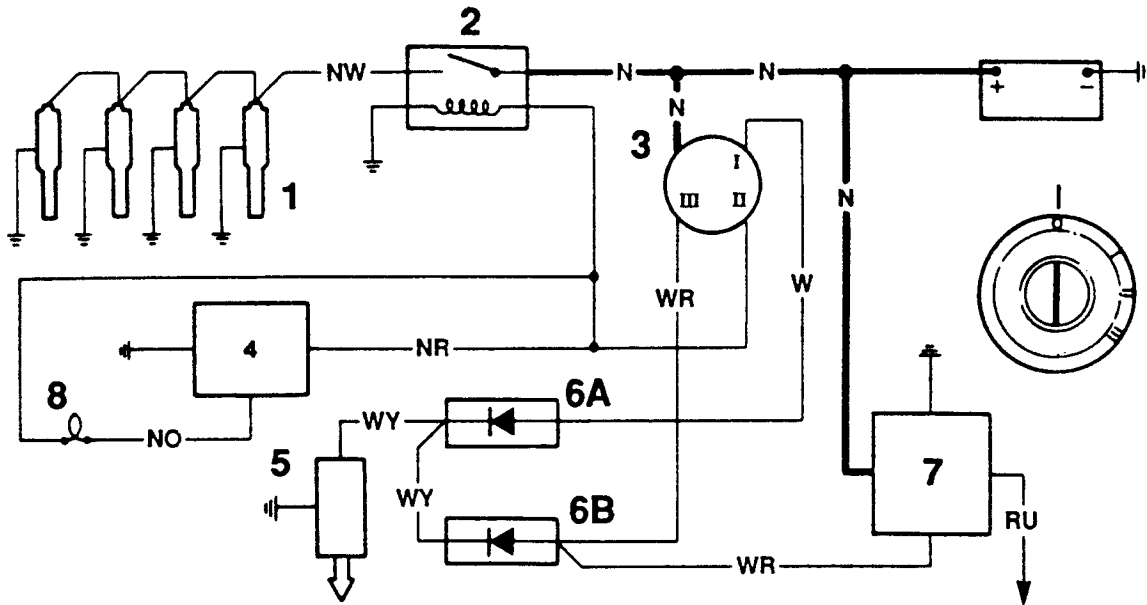

**Fig. 2**

**IGNITION SWITCH POSITION 0** (see Fig.2)  
Steering locked, nothing is energised from the ignition switch.

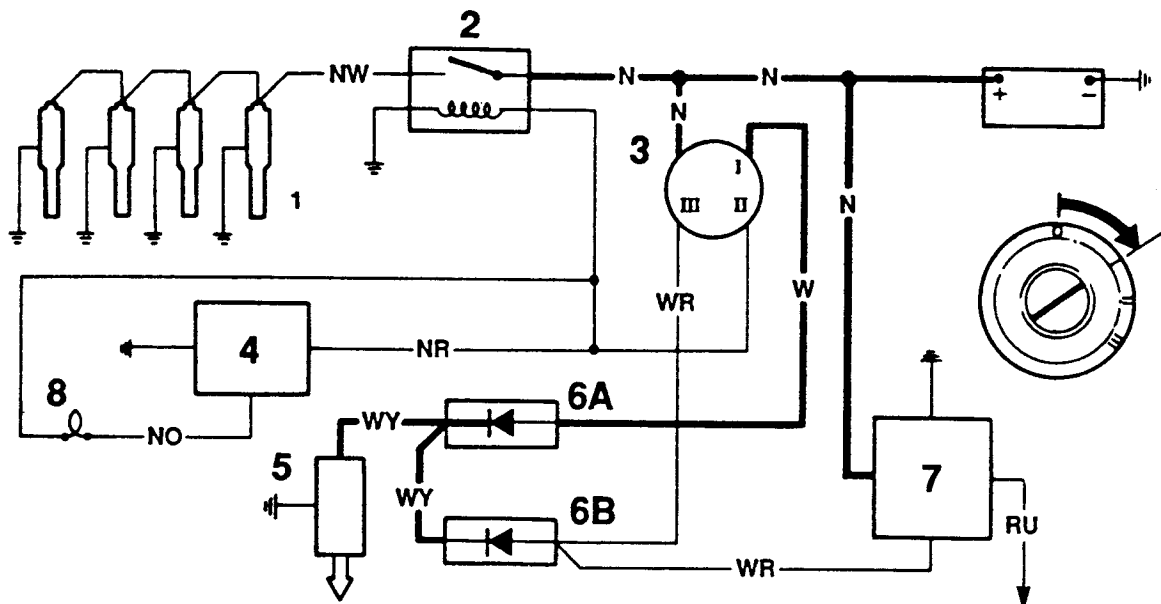

**Fig. 3**

**IGNITION SWITCH POSITION 1** (see Fig.3)  
Steering unlocked, normal engine run position. In position I (shown on the switch in the wiring diagram), the white wire becomes live, feeding

to diode 6A, through this diode to the fuel cut-off solenoid, 5, down the white/yellow wire linking diodes 6A and 6B is also live, but diode

6B prevents alive feed passing to the starter relay via the white/red wire. (If diode 6B fails

closed circuit, the starter motors will operate all the time the ignition switch is in position I).

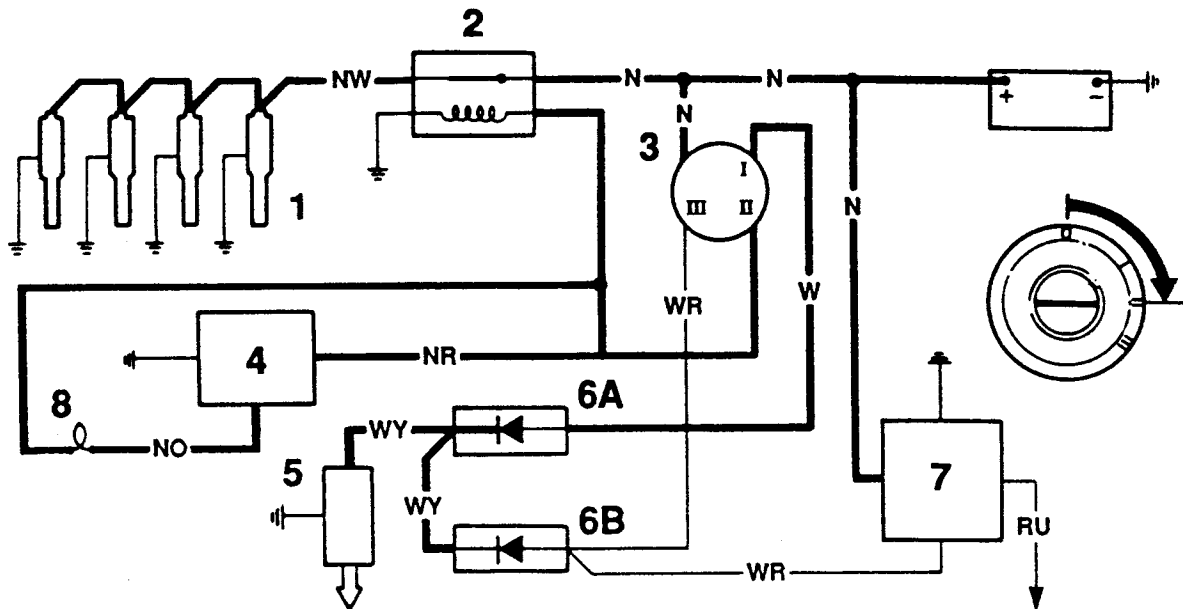

Fig. 4

**IGNITION SWITCH POSITION II – Heater plugs on (see Fig.4)**

The ignition switch must be held against a spring loading. The fuel cut-off solenoid is energised as before (see previous diagram).

In addition, the heater plugs are now energised by feeding from position II on the ignition switch to the heater plug relay (2) down the Brown/Red wire. This activates the relay, the contacts close, and the heater plugs are fed from the relay by the Brown/White wire.

At the same time in position II, the heater plug warning light unit (4) is switched on by a feed from the Brown/Red wire. This unit in turn switches on the heater plug dash light (8). After a period of approximately fifteen seconds the heater plug dash light is switched off by the heater plug warning light unit. All the time the ignition switch is held in position II, even after the heater plug dash light has gone out, the heater plugs are still operating.

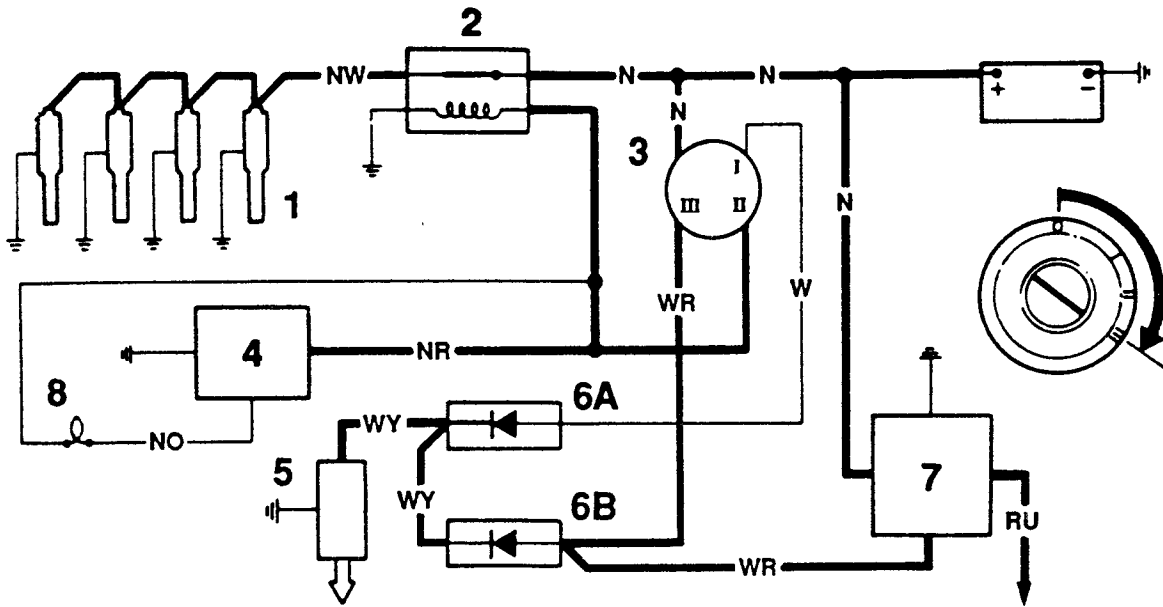

**Fig. 5 IGNITION SWITCH POSITION III – Cranking (See Fig.5)**

In this position, the circuit in position I is now switched off, by virtue of the ignition switch design. Consequently, the fuel cut-off solenoid cannot be energised through blocking diode 6A. Instead, from position III on the ignition switch, a live feed comes down the White/Red wire to diode 6B, feeding to the fuel cut-off solenoid down the White/Yellow wire. Diode 6A prevents the white wire to terminal I of the ignition switch becoming live.

A feed is also taken from diode 6B, a White/Red wire, to the starter relay (7) which energises the starter by closing the contacts and feeding from the Brown wire to the starter through the Brown/Blue wire. In position III the heater plugs are operating as before (see Fig.4). Upon releasing the key, it will return by spring action to position I.

## HEATER PLUGS

VEHICLES AFTER VIN 258340

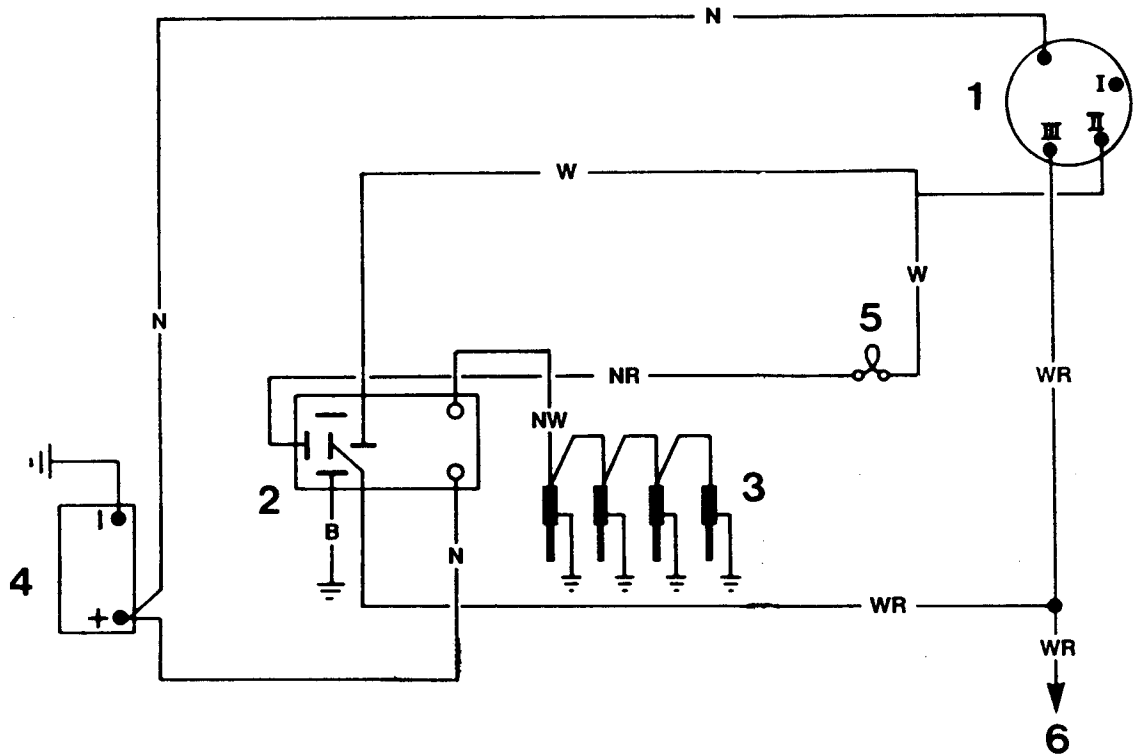

### Key to wiring diagram

- |                            |                              |
|----------------------------|------------------------------|
| 1. Ignition switch         | 4. Battery                   |
| 2. Heater plug control box | 5. Heater plug warning light |
| 3. Heater plugs            | 6. To starter solenoid relay |

### Wiring colour code

- N Brown  
 W White  
 Y Yellow  
 B Black  
 O Orange  
 R Red

### System Operation

#### Ignition switch position 'O'

There is a current supply from the battery to the ignition switch (1), and the heater plug controller (2).

#### Ignition switch to position 'II' (before cranking)

The heater plug controller (2) contains an ambient temperature sensor. If the ambient temperature is low, the sensor will allow the heater plug controller to be energised and switch on its internal relay to allow current to

pass to the heater plugs (3). The heater plug warning light (5) will illuminate.

After a maximum period of approximately 7 to 11 seconds the heater plug warning light will go out, telling the driver that there has been sufficient 'pre-heat' time and the engine is ready to start. The 7 to 11 second time factor will be progressively less depending on ambient temperature at the time of cranking, and if the engine is hot the light will flash on for less than one second.



After the heater plug warning light has gone out, the heater plug controller will, irrespective of ambient temperature, hold its internal relay on for a further 9 seconds only. This is to ensure that the heater plugs are not left on indefinitely if the ignition key remains in position II.

**Ignition switch position 'III' (cranking)**  
Current passes to the starter solenoid (6) to crank the engine. Current is also supplied to the heater plug controller via the white/red (WR) wire to ensure its internal relay remains energised. This ensures that the heater plugs will remain in operation during cranking.

**Ignition switch position 'II' (engine running)**  
Under cold ambient conditions the heater plug controller will continue to energise its internal relay for approximately 10 seconds, to ensure smooth engine running. This is known as the post-heat period.

As with pre-heat, the post-heat period becomes less as ambient temperature increases until, with a hot engine, the post-heat period is approximately 1 second maximum.

### **Heater plug testing**

The heater plugs must be tested off the engine using the Dieseltune DX900 tester.

### **Testing off the engine**

Push the heater plug into the clamp at the end of the tester. Connect the tester leads as follows:

- Red lead to battery positive
  - Black lead to battery negative
  - Yellow lead to heater plug centre terminal
- Depress the 'TEST' button; note the initial current draw and how long the current takes to stabilise, by observing the LED's which illuminate at 5 second intervals. Also note whether the heater plug glows at the tip first; if it doesn't, then it must be renewed. Repeat and record results on all heater plugs. Check the results with the figures given in "Engine tuning data".

### **Heater plug relay and control box test**

Connect the red lead to the heater plug feed wire from the main harness, leaving the other two wires connected as in previous tests. Depress and hold the 'TEST' button; turn on the master key and note the time taken for the dial needle to drop to zero. Use the LED timing scale as in previous tests.

### **Installation**

The heater plug should be installed in the cylinder head using a high temperature (1000°C) anti-seize compound applied to the cone seat and thread, and tightened to 20 Nm. **NOTE:** The heater plug has a taper seat and therefore the tightening torque is important.



**Marketing and Sales  
Vans**

Technical Service  
1 Cornwall Street  
Birmingham B3 2DT

Tel: (021) 233 0011  
Fax: (021) 233 8505