

Service Workbook

AUTOMATIC TRANSMISSION - 400

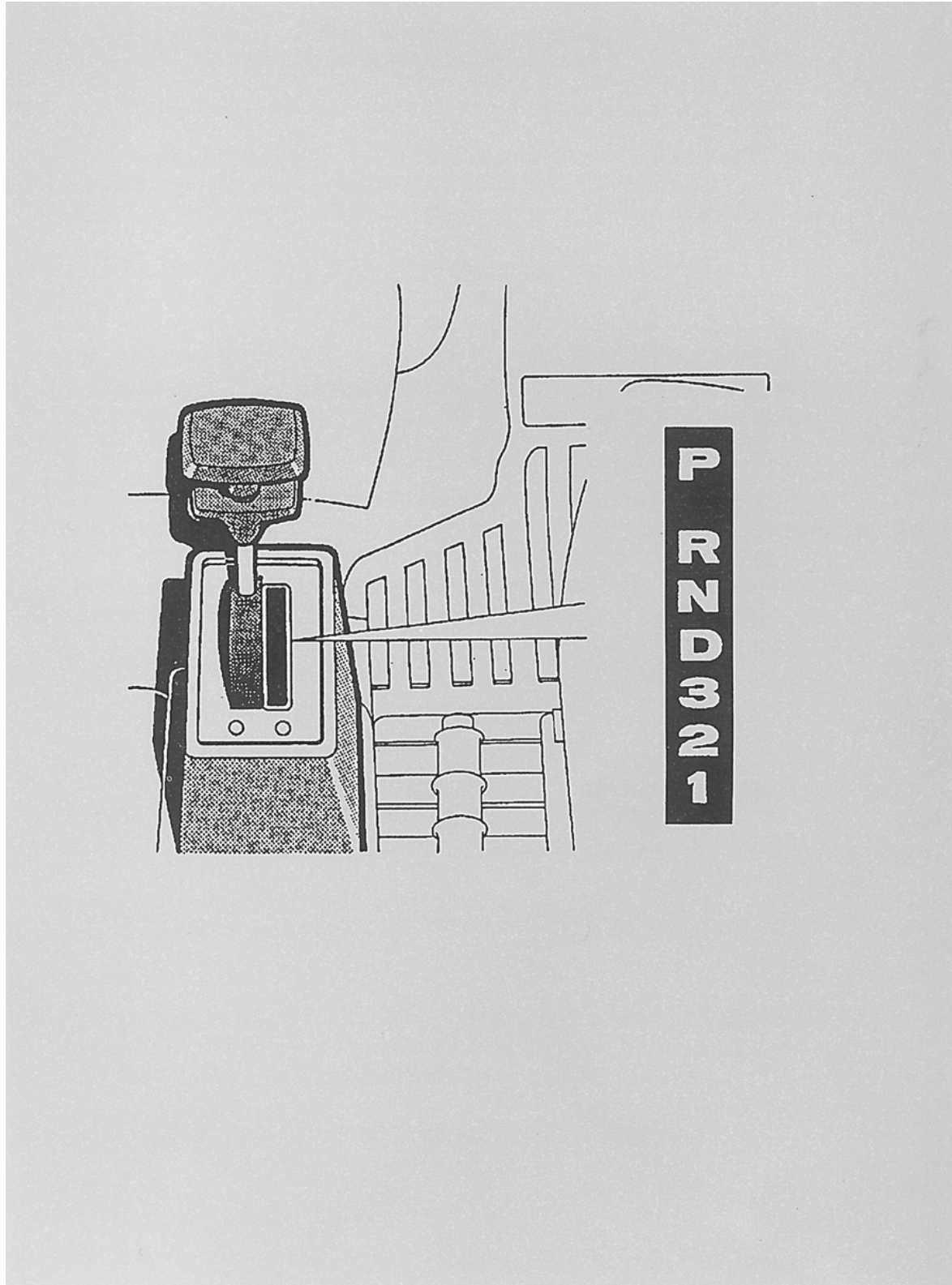

AUTOMATIC TRANSMISSIONS

Service Workbook

This Service Workbook covers the A-727, A-518 and ZF transmissions fitted to 300 and 400 models. It is primarily designed to assist skilled technicians in the efficient maintenance of these transmissions, but can also be used as a reference workbook for training purposes.

This Service Workbook should always be consulted prior to servicing or repair work.

SPECIFICATION

Leyland DAF (the Company) reserves the right to change the procedures, material, specification, dimensions or design of the vehicles shown, described or referred to herein at any time and without prior notice in accordance with the Company's policy of constant product improvement.

Every reasonable effort is made to ensure that the Company's publications are accurate, but nothing shown, described or referred to herein should be regarded as an infallible guide to the procedures, materials, specifications, dimensions, design or availability of any particular vehicle, nor does this publication constitute an offer for the sale of any particular vehicle. No liability can be accepted by the Company or any Distributor or Dealer for any mechanical malfunction, damage, loss, injury or death caused by the use of incorrect or misrepresented information, omissions or errors that may have arisen during the preparation of this workbook.

Purchasers are advised that the specification details set out in this publication apply to a range of vehicles and not to any particular vehicle. For the specification of any particular vehicle, purchasers should consult their Leyland DAF Vans Distributor or Dealer. Please note that Leyland DAF Vans Distributors and Dealers are not agents of the Company, and have no right or authority whatsoever to bind the Company in any way, or to assume on its behalf any obligation expressed or implied.

COPYRIGHT

© Leyland DAF 1992

All rights reserved. No part of this publication may be reproduced, stored in a retrieval system or transmitted, in any form, whether electronic, or mechanical, or by photocopying, recording or other means without prior permission in writing of Leyland DAF.

Published by Leyland DAF Vans, from whom further copies may be obtained.

LEYLAND
DAF

SECTION 1

TORQUEFLITE A-727 and A-518

Pages 5 to 13

SECTION 2

ZF 4 HP 22

Pages 15 to 22

SECTION 1**TORQUEFLITE A-727 and A-518****CONTENTS**

	Page
Description	6
Data	7
Driving the vehicle	7
Gear selector	7
Starting the engine	7
Selector positions and driving the vehicle	8
Maintenance	9
Oil level check	9
Fluid and filter change	9
Selector position check	10
Adjustments	11
Selector linkage	11
Kickdown band	11
Low - Reverse band	11
Throttle pressure control cable	12
Stall testing	13

DESCRIPTION

A-727

Fitted to 300 models with BN52 diesel engine.

The transmission combines a torque converter with a fully automatic gear system. Three forward speeds and reverse are provided by two planetary gear sets, controlled by two multiple disc clutches, a one-way clutch, two servos and brake bands. Automatic operation of the clutches and servos is provided hydraulically, dependent on road speed and throttle operation.

A-518

Fitted to 400 models with EN55 and ET70 engines.

This transmission is a four speed unit, and is a development of the A-727 transmission. 1st, 2nd and 3rd gears and reverse gear are as for the A-727; 4th gear is provided by fitting a 0.69 ratio overdrive unit to the output shaft. This overdrive is controlled electronically by an E.C.U. which receives signals from two sensors – a potentiometer (fig.1) mounted on the fuel injection pump to sense throttle position, and a sensor (fig.2) in the speedometer drive cable and mounted on the chassis to record road speed.

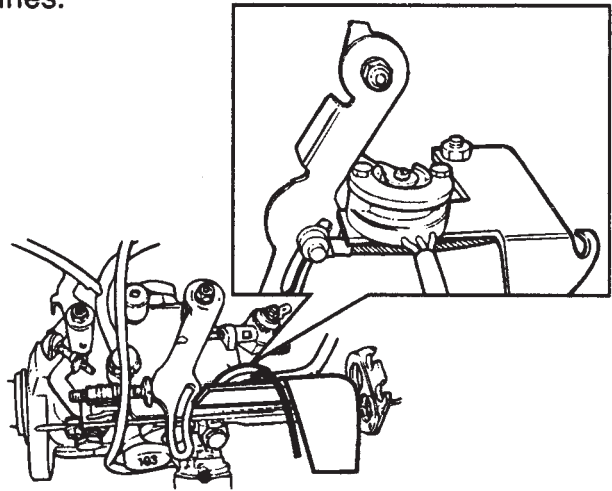

Fig.1 Throttle sensor

The E.C.U.(fig.3) is located in the fascia under the ashtray, and is protected by a 7.5 amp fuse in either the A8 or C1 location in the fuse box depending on vehicle type. A sticker inside the fuse box cover indicates which position is used.

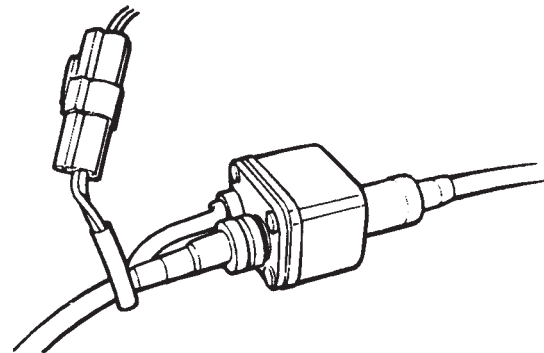

Fig.2 Speed sensor

Another feature of the A-518 is the inclusion of a high stall lock-up unit in the torque converter. This lock-up is a hydraulically operated disc clutch, electronically controlled, which provides a mechanical link between the impeller and the turbine when specified road speed and throttle position criteria are met, and thereby eliminate any slippage loss in the torque converter when engaged.

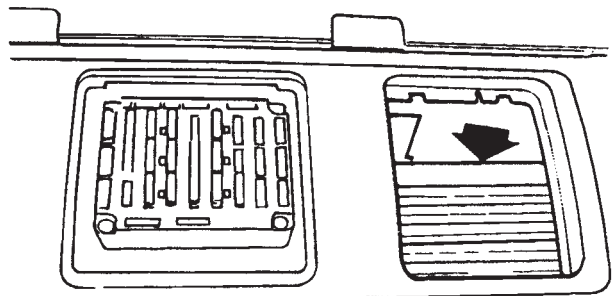

Fig.3 E.C.U.

DATA

	A-727	A-518
Gears	Three forward speeds and reverse	Four forward speeds and reverse
Oil specification/type	Dexron II Automatic Transmission Fluid	
Capacity - drain and refill *	3.4 litres (6 pts) (nominal)	4.6 litres (8 pts) (nominal)
Gear ratios	First	2.45
	Second	1.45
	Third	1.00
	Fourth	0.69
	Reverse	2.20
Control system	Hydraulic	Electro-Hydraulic
Governor type	Hydraulic	Hydraulic

* New gearboxes and torque converters are supplied part filled, and fluid levels should be checked as described on page 9.

Gearchange speeds

Upshifts		Minimum throttle	10 to 13 mph (16 to 21 kph)
1 to 2	Minimum throttle		
	Full throttle		24 to 26 mph (38 to 42 kph)
2 to 3	Minimum throttle		18 to 25 mph (29 to 40 kph)
	Full throttle		36 to 39 mph (58 to 61 kph)
3 to 4	Full throttle (A-518)		61 mph (98 kph)

TORQUEFLITE

DRIVING THE VEHICLE

Gear Selector

The selector lever has six positions:

- P** - Park
- R** - Reverse
- N** - Neutral
- D** - Drive
- 2** - Second
- 1** - First

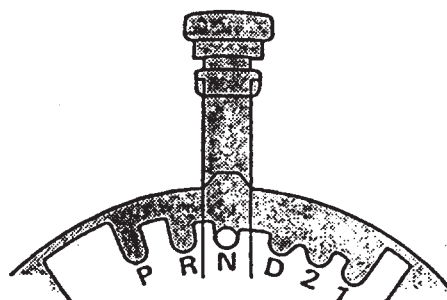

Fig.4 Gear selector positions

A collar under the selector lever knob must be lifted to engage 'P', 'R' or '1'.

WARNING: The vehicle should be stationary with the handbrake or footbrake applied fully before selecting any of the forward or reverse drive ranges.

CAUTION: Do not engage 'R' or 'P' when the vehicle is in motion.

Starting The Engine

The engine will only start in P or N.

When starting in N, apply the hand or footbrake first.

Selector Positions and Driving the Vehicle

'P'

A mechanical parking lock is applied by moving the selector past a gate to the **P** position.

CAUTION: Do NOT attempt to select **P** while the vehicle is in motion; it must be brought to a complete halt before engaging **P**.

'R'

Do not select **R** while the vehicle is moving forwards.

'N'

In **N** (neutral), the engine can be started and run; the mechanical parking lock is disengaged and therefore the foot or handbrake should be applied.

'D'

D (Drive) is used for all normal driving conditions; from rest the transmission will start in **1** (low) gear and then change up and down automatically through all four forward gears (three forward gears on A-727 transmission). The change points will vary depending on road speed and throttle position.

For maximum acceleration when **D** is selected, depress the accelerator fully (kick down). This will result in **1** (low) gear being engaged at speeds up to 24 to 26 mph (38 - 42 kph), and **2** (intermediate) gear being engaged at speeds up to 36 to 38 mph (58 to 61 kph). When the accelerator pedal is released from the fully depressed position, the normal automatic up and down changing will resume.

NOTE: 4 speed gearbox – It is not possible to select **3** directly; 3rd and 4th gear will only be selected with the lever in the **D** position.

'2'

In **2** (intermediate) the transmission will change up and down automatically between **1** and **2** only, it will not change into 3rd or 4th gear (3rd gear on A-727) until **D** is selected.

CAUTION: Do not engage **2** from **D** at speeds above 36 mph (58 kph).

The **2** position should be selected when driving in hilly terrain, to avoid unnecessary labouring of the engine when driving uphill, and to give moderate engine braking downhill.

'1'

The **1** position provides operation in **1** (low) gear only.

If **1** is selected from **2** or **D** when the vehicle is moving, first gear will only engage if the road speed is very low or if the accelerator pedal is fully depressed (kickdown). In the latter case, low gear will be obtained at all speeds up to approximately 20 mph (32 kph).

Once **1** (low) gear has been engaged, no automatic upchanges occur and care should be taken not to run the engine at maximum governed speed for prolonged periods.

1 (low) gear should be used when driving in very hilly terrain, particularly when towing a trailer, to avoid the engine labouring when driving uphill and provide engine braking downhill.

When driving downhill, care should be taken to ensure that the engine does not exceed maximum governed speed.

MAINTENANCE

- | | |
|--------------------|--|
| Every week | - Check transmission fluid level. |
| Every 12,000 miles | - Renew transmission fluid and filter. |
| | - Adjust both brake bands. |
| | - Check selector positions |

NOTE: Under arduous conditions this maintenance requirement should be reduced to 8,000 miles.

Oil level check

Before checking the level the transmission fluid should be at normal operating temperature, and the vehicle positioned on level ground; then proceed as follows:

Apply the hand and footbrake, start the engine, allow it to run at idle speed, slowly select all gears and then select **N** (neutral).

Withdraw the dipstick from the filler tube and wipe the blade with a piece of clean paper or a lint-free cloth. Re-insert the dipstick fully, withdraw it immediately and check the fluid level indication.

There are two marks 'ADD' and 'FULL' and, at normal operating temperature, the level should be at the 'FULL' mark. If low, add fluid in small quantities at a time, and re-check at intervals until the level is correct.

- NOTE:**
- The correct reading will ONLY be obtained when the fluid is at normal operating temperature.
 - The level must NOT be checked in **P**.

CAUTION: Do NOT overfill above the 'FULL' mark.

Ensure that dipstick/filler cap is replaced correctly to avoid ingress of dirt.

Fluid and Filter Change

1. Raise the vehicle on a hoist. Place a container with a large opening and a suitable capacity under the transmission sump.
2. **WARNING: The transmission fluid will be hot if the vehicle has been driven recently.**
Remove the drain plug and drain the fluid.
3. Loosen the sump bolts and lightly tap the sump at one corner to break the seal. Then remove the sump and empty any remaining fluid. Discard the sump gasket.

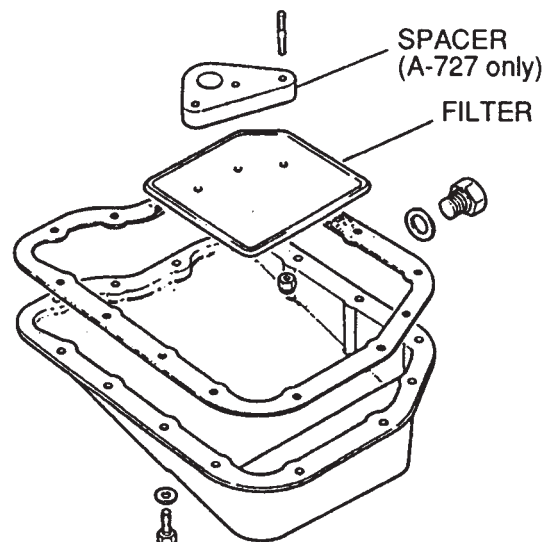

Fig.5 Sump (Spacer not fitted in A-518 transmission)

4. Release the three securing screws to remove and discard the filter. Recover the spacer located above the filter (not fitted on A-518 transmission).
5. Clean all components and examine for signs of damage. Clean the magnet located in the sump.
NOTE: Total cleanliness must be observed at all times.
6. Adjust the low-reverse band. (See 'Band Adjustments')
7. Fit the spacer (A-727 transmissions only) and a new filter, and tighten the retaining screws to 4 Nm (3 lbf ft.).
8. Check that the magnet is correctly located over the bump in the front, right hand corner of the sump.
Fit the sump using a new gasket. Apply Loctite to the sump securing bolts before fitting them, and torque tighten to 8 Nm (6 lbf ft.).
9. Fill the transmission with of the recommended fluid.
A-727 (3 speed) – 3,4 litres (6 pints)
A-518 (4 speed) – 4.6 litres (8 pints)
10. Start the engine and allow to idle for at least two minutes. Then, with the hand and footbrakes applied, move the selector slowly through each of its six positions, pausing momentarily at each position, and ending in 'N'.
11. Check the fluid level with the dipstick and add sufficient fluid to bring the level to the '**ADD**' mark. Continue to run the engine until the gearbox oil has reached normal operating temperature and re-check the fluid level.
The level should then be between the '**ADD**' and '**FULL**' marks when the vehicle is on level ground. Top up if necessary.

Selector Position Check.

With the engine stationary, move the selector forward until it clicks positively into the 'P' position. Turn the master key to see if the starter will operate. If it does, the 'P' position is correct.

Slowly move the selector rearwards towards 'N'. and check that the lever clicks positively into the 'N' position. Check again to see if the starter will operate.

If the starter operates correctly in both 'P' and 'N', the selector cable is correctly adjusted. If not, adjust the cable as described in 'Selector Linkage Adjustment'.

ADJUSTMENTS

Selector Linkage

The adjustment is made by altering the length of the cable between the selector and the selector lever on the transmission as follows:

1. Disconnect the selector cable yoke at the selector lever on the transmission.
2. Position the selector in the 'N' position.
3. Place the transmission in neutral by first moving the selector lever fully forward, then moving it three detents to the rear.
4. Adjust the cable length at the disconnected yoke until the clevis pin hole in the yoke aligns with the rearmost hole in the selector lever. Fit the yoke and tighten the lock nut.
5. Re-check the selector position.

Kickdown Band (Front)

The kickdown band adjusting screw is located on the left side of the transmission housing.

1. Slacken the kickdown band adjuster lock nut by approximately five turns. Check that the adjuster can turn freely in the casing.
2. Torque tighten the kickdown band adjuster to 8 Nm (6 lbf ft.). Slacken the adjuster by two and one half turns. Tighten the lock nut while holding the adjuster from turning.

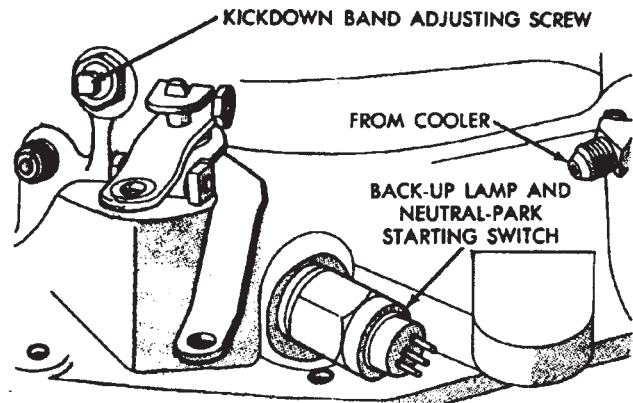

Fig.6 Kickdown band adjustment

Low-Reverse Band (Rear)

This band adjuster is internal and adjustment is made after removing the sump.

1. Remove the sump (see 'Oil and Filter Change' for details).
2. Slacken the low-reverse band adjuster lock nut by approximately five turns. Check that the adjuster can turn freely in the lever.
3. Torque tighten the low-reverse band adjuster to 8 Nm (6 lbf ft.). Slacken the adjuster by two turns. Tighten the lock nut while holding the adjuster from turning.

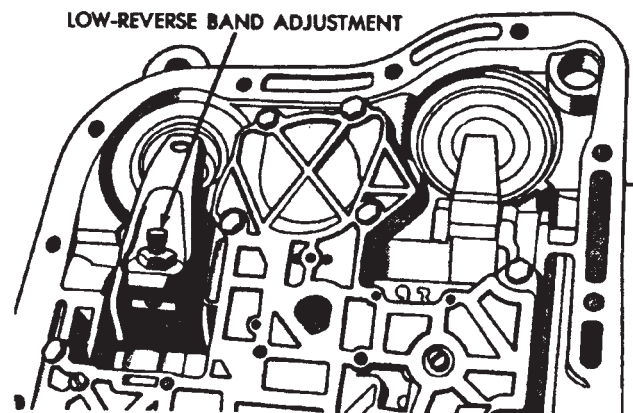

Fig.7 Low-Reverse band adjustment

4. Refit the sump using a new gasket, refill with the correct specification oil, check the level, (see 'Oil and Filter Change' for all procedures).

Throttle Pressure Control Cable

Correct control cable length is essential to proper transmission operation; an incorrect adjustment can cause faulty shift speeds, shift quality and down shift sensitivity. The check / adjustment is made as follows:

1. Fit a pressure gauge to the rear servo apply pressure port, situated at the right rear of the transmission main case.
2. Chock the road wheels, apply hand and footbrakes and start the engine.
3. With the engine idling, select 'R' and note the pressure reading; it should read 150 - 160 psi.

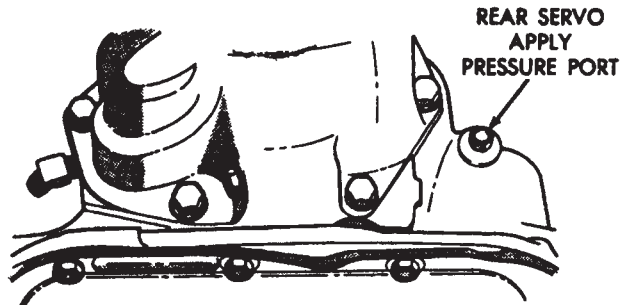

Fig.8 Pressure gauge attachment point

4. Check that the hand and footbrakes remain applied, select 'R' and depress the accelerator fully (**CAUTION: for not more than 5 seconds**) and note the pressure reading again. It should read 260 - 270 psi.
CAUTION: If more than one test is required, run the engine at 1000 rpm in 'N' for 20 seconds to cool the transmission fluid between tests.
5. If the pressures are incorrect, adjustment is made by altering the length of the pressure control cable. This can be done at either end of the cable, at the fuel injection pump or at the transmission.
Shortening of the inner cable will raise the pressure, and lengthening will lower the pressure.
6. After making the adjustment, carry out both pressure checks again to ensure correct readings.

STALL TESTING

Procedure

1. Connect an accurate tachometer to the engine.
2. Ensure that the transmission fluid is the correct type and to the correct level.
3. Chock all the road wheels securely and apply the hand and foot brakes.
4. Start the engine, select 'D' and depress the throttle fully for **NOT MORE THAN 5 SECONDS**. Note the maximum engine rpm reached on the tachometer.

CAUTION: If more than one test is required, run the engine at 1000 rpm in 'N' for 20 seconds to cool the transmission fluid between tests.

Analysis

Good Condition - stall test speed 2,000 ± 100 rpm. BN52 and EN55 engines
 2,275 ± 100 rpm. ET70 engine

If the engine (see 'Engine Performance' below), torque converter and transmission are in good condition, the engine speed should reach but not exceed the speed given above.

Seized Stator - stall test speed 2,000 ± 100 rpm. BN52 and EN55 engines
 2,275 ± 100 rpm. ET70 engine

This stall test will achieve the same engine speed as for a torque converter in good condition. However on road test, low speed acceleration will be correct, but higher road speed performance will be poor, top speed will be low and overheating will occur.

Slipping Stator - stall test speed 1,000 rpm max.

The stall test engine rpm will be very low, maximum 1,000 rpm. On road test. acceleration will be poor but higher road speed performance and top speed will be correct.

Engine Performance - stall test speed 1,000 - 2,000 rpm.

The actual engine speed achieved by a stall test is very much dependent on engine condition. An engine in poor condition or with faulty fuel injection equipment will reach a stall test speed of 1,000 to 2,000 rpm, assuming the torque converter and gearbox are in good condition.

Transmission condition - stall test speed exceeds 2,000 rpm.

If during the stall test the engine speed exceeds 2,000 rpm and continues to rise, this indicates that a clutch or brake band is slipping.

NO FURTHER TESTING SHOULD BE CARRIED OUT UNTIL THE SLIP IS RECTIFIED.

SECTION 2

ZF 4 HP 22

CONTENTS	Page
Data	16
Driving the vehicle	17
Gear selector	17
Selector operation	17
Gearchanging	18
Maintenance	19
Fluid level check	19
Fluid and filter screen change	20
Adjustments	21
Selector lever cable	21
Kickdown cable	21
Stall testing	22

DATA

Type	-	ZF 4 HP 22	1043 010 317
Gears	-	Four forward speeds and reverse.	
Capacity	- new	-	9,10 litres (16 pints)
	- drain and refill	-	5,50 litres (9.70 pints)
Fluids	-	BP	Autran DX II
	-	Castrol	TQ Dexron II
	-	Elf	Elfmatic G2
	-	Esso	Esso Automatic Transmission fluid Dexron
	-	Fina	Fina Dexron
	-	Mobil	Mobil ATF 220
	-	Shell	Shell ATF II
	-	Texaco	Texamatic 9226
		Total	Total Dexron
Gearchange speeds			
Upshifts	1 to 2	Minimum throttle	9 to 10 mph (14 - 16 kph)
		Full throttle	24 to 28 mph (39 - 46 kph)
		Kick down	29 to 34 mph (47 - 54 kph)
	2 to 3	Minimum throttle	19 to 23 mph (31 - 37 kph)
		Full throttle	44 to 49 mph (71 - 79 kph)
		Kick down	48 to 53 mph (78 - 85 kph)
	3 to 4	Minimum throttle	28 to 31 mph (45 - 50 kph)
		Full throttle	61 to 71 mph (99 - 114 kph)
		Kick down	69 to 78 mph (111 - 126 kph)
Downshifts (Hand selection)			
	4 to 3	All speeds	
	3 to 2	50 to 57 mph (81 - 92 kph)	
	2 to 1	27 to 32 mph (43 - 51 kph)	
Torque converter lock up	In (acceleration)	38 to 41 mph (61 - 66 kph)	
	Out (deceleration)	37 to 40 mph (59 - 64 kph)	

DRIVING THE VEHICLE

Gear Selector

The selector housing is marked with the symbols **P, R, N, D, 3, 2** and **1** which indicate the following functions:

- P** Park
- R** Reverse
- N** Neutral
- D** Drive
- 3** First, second and third gears only
- 2** First and second gears only
- 1** First gear only with engine braking

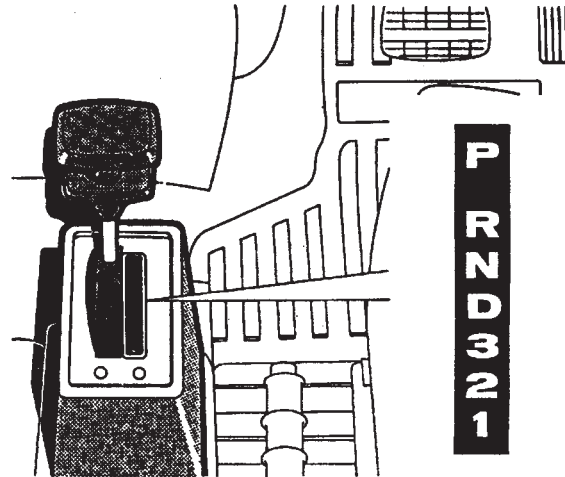

Fig.1 Gear selector

Selector Operation

The selector movement is restricted to facilitate selection. Those positions normally used in sequence are grouped together to prevent inadvertent engagement of **N, R, P** or **1**.

The selector is spring-loaded and moves in an indented gate as illustrated. Movement across the indents is effected by lifting the sliding collar (fig.2, A) below the knob, thereby releasing a spring loaded catch to allow the selector to move and engage the desired gear.

The selector will move freely between **D** and **3**, with an additional stage of interlock protecting the **P** position from the **R** position.

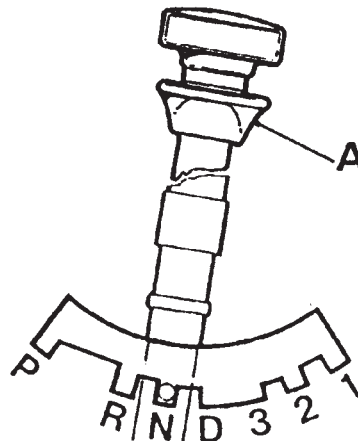

Fig.2 Gear selector positions

WARNING: The vehicle should be stationary with the handbrake or footbrake applied fully before selecting any of the forward or reverse drive ranges.

CAUTION: Do not engage R or P when the vehicle is in motion.

Gearchanging

Fig.3 Accelerator Pedal Positions

- A Idle
- B Part throttle
- C Full throttle (at kickdown cam)
- D Kick down

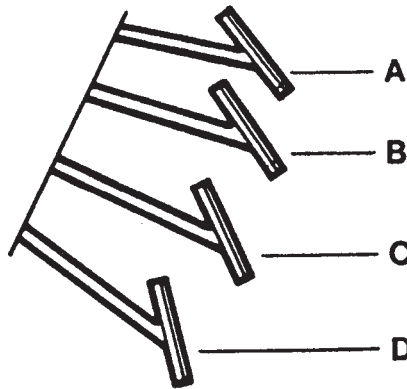

'D' Drive Range

The **D** position provides full automatic up and down changes through all forward gears, depending on vehicle speed and accelerator position.

Use **D** for all normal driving on good roads. The gearchange points have been chosen to give best fuel economy during normal driving with moderate accelerator positions.

For maximum acceleration when **D** is selected, the accelerator pedal can be pushed fully down (kick down). This will automatically result in first gear being engaged at speeds up to 34 mph (54 kph) and second gear being engaged at speeds up to 53 mph (85 kph). If the accelerator pedal is kept fully down, third gear will be the highest gear engaged.

When the accelerator pedal is released from the kick down position, fourth gear will be engaged and the normal automatic up and down changes will resume.

When in **D**, downshifts to lower gears can be obtained by pushing the accelerator pedal partly down. The speed at which downshifts occur is dependent on throttle position and on road speed.

Above speeds of approximately 40 mph (64 kph), provided the vehicle is in 4th gear an automatic system locks the torque converter, eliminating slip in **D** only, as a further aid to fuel economy.

'3'

The **3** position provides automatic up and down changes between first, second and third gears only.

For maximum acceleration when in **3**, the accelerator can be pushed fully down (kick down) which will result in first or second gears being engaged, depending on road speed. When the accelerator is released from the kick down position, normal automatic changes between first, second and third gears will resume.

If **3** is selected from **D** with the vehicle in 4th gear, third gear will be engaged.

CAUTION: Do not engage '3' at speeds above 78 mph (126 kph).

'2'

The **2** position provides automatic up and down shifts between first and second gears only. For maximum acceleration when in **2** the accelerator can be depressed fully (kick down), which will result in first gear being engaged depending on road speed. When the accelerator is released from the fully depressed position, normal automatic changes between first and second gear will resume.

Position 2 can be selected at any road speed but, if the road speed is too high for second gear, third will be engaged and immediately followed by second when the road speed has fallen to an appropriate level.

CAUTION: Do not engage '2' at speeds above 53 mph (85 kph).

Once second gear has been engaged, no upshift will occur until 3 or D is selected.

CAUTION: Care should be taken not to over-rev the engine in this condition.

The 3 or 2 position should be selected when driving in hilly terrain to avoid unnecessary labouring of the engine when driving uphill. 2 will give moderate engine braking downhill.

'1'

The 1 position provides operation only in first gear. If 1 is selected from 2, 3 or D with the vehicle moving, first gear will only engage if the road speed is very low, unless the accelerator pedal is fully depressed (kick down). In this case, first gear will be obtained at all speeds up to approximately 34 mph.

CAUTION: Once 1 has been engaged no automatic upshift will occur, and care should be taken not to over-rev the engine.

The 1 position should be used when driving in very hilly terrain, particularly when towing a trailer, to avoid the engine labouring when driving uphill, and provide the necessary engine braking downhill.

MAINTENANCE

Fluid Level Check

The dipstick (fig.4, 1) is marked with maximum and minimum levels (fig.4, 2).

To check the level, the fluid should be cold, the vehicle on level ground and the hand and footbrake applied. Start the engine, allow it to run at idle speed, slowly select all gears and then select N (neutral).

Withdraw the dipstick from the filler tube and wipe the blade with a piece of clean paper or a lint-free cloth. Re-insert the dipstick fully, withdraw it immediately and check the fluid level indication. This must be between the maximum and minimum marks on the dipstick.

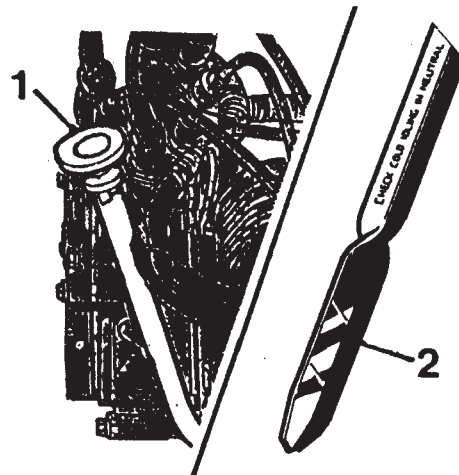

Fig.4 Dipstick

For consistent results repeat the level check.

If necessary top up via the combined filler tube / dipstick (1) using the correct grade of fluid. Do NOT overfill. After checking the fluid level, ensure that the dipstick is resealed correctly to prevent dirt or water from entering the transmission.

CAUTION: To check from a dry fill, the gearbox must be part filled before starting.

Fluid and Filter Screen Change

Intervals

Change fluid and filter screen every 24,000 miles.

Change Procedure

WARNING: The sump and the transmission fluid will be hot if the vehicle has been driven recently.

1. Position the vehicle on a hoist, open the bonnet and remove the transmission dipstick to aid drainage.
2. Raise the vehicle to a convenient working height, position a suitable drainage container of at least 10 litres (2.2 gallons) capacity under the transmission drain plug (1). Remove the drain plug and discard its sealing washer; allow the fluid to drain completely.
3. Release the large nut (2) securing the filler tube to the sump and detach the tube.

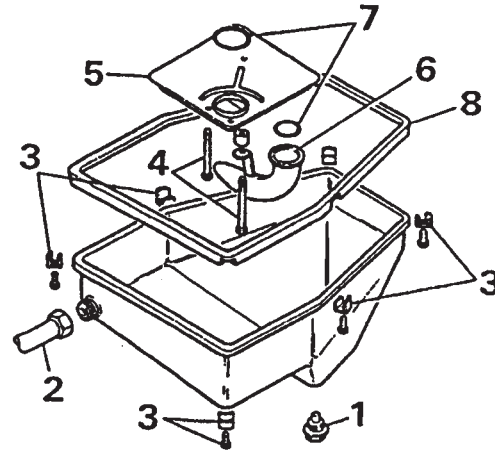

Fig.5 Sump

4. Release the six bolts, washers and clamps (3) retaining the sump and remove the sump. Discard the gasket (8) if damaged.
 5. Remove the three screws and washers (4) securing the fluid screen (5) to the valve body and remove the screen. Separate the screen from the suction tube (6) and discard the screen and 'O' rings (7).
 6. Clean all components and examine for signs of damage.
- NOTE:** Total cleanliness must be observed at all times.
7. Fit two new 'O' rings to the new fluid screen using petroleum jelly to hold in position.
 8. Fit the suction tube to the fluid screen and fit the screen, tightening the three securing screws to a torque of 8 Nm (6 lbf ft).
 9. Fit a new gasket to the sump and refit the sump using all securing screws and clamps. Torque tighten the four corner clamps first, followed by the two centre clamps to 8 Nm (6 lbf ft).
 10. Reconnect the filler tube to the sump and tighten the large nut to a torque of 35 to 42 Nm (25 - 30 lbf ft.).
 11. Clean and refit the drain plug with a new sealing washer, and torque tighten to 25 Nm (18 lbf ft).
 12. Refill the transmission through the filler / dipstick tube with 5,50 litres (9.70 pints) of the correct grade of fluid.
 13. Start the engine, and check and top up the fluid level as described in 'Fluid Level Check'.

ADJUSTMENTS

Fig.6 Selector Lever Cable

1. Selector lever on transmission
2. Trunnion

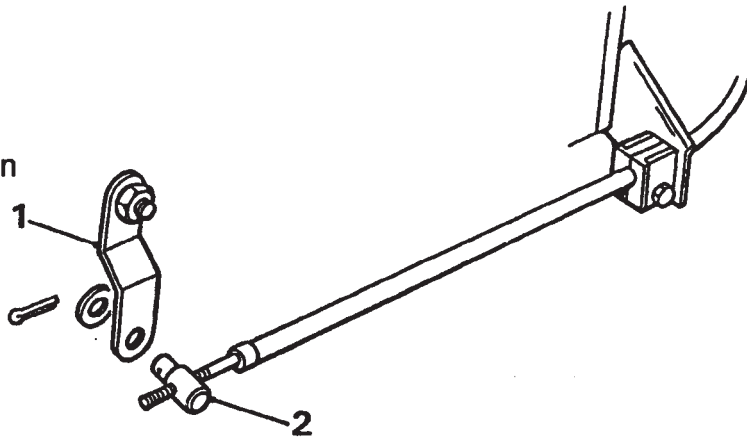

Selector Lever Cable

1. Remove the split pin and washer securing the cable trunnion (fig.6, 2) to the selector lever (fig.6, 1) on the transmission, and disconnect the trunnion from the lever.
2. Select neutral on the transmission by moving the selector lever fully forward, then moving it rearwards by two detents.
3. Select neutral at the selector in the cab.
4. Turn the trunnion clockwise or anti-clockwise until it will fit exactly into its location in the selector lever (i.e. without having to move the lever backwards or forwards). Check that the trunnion is free to turn in the selector lever then secure with the washer and a new split pin.
5. Apply hand and footbrakes, start the engine and allow to idle. Move the selector to each position in turn and check for a positive engagement of the appropriate gear.

Kickdown Cable

The kickdown inner cable is attached to the carburettor linkage, and the outer cable (1) is attached to a bracket on the left hand rocker cover. The length of the cable can be adjusted at this point by altering the position of the two lock nuts (2).

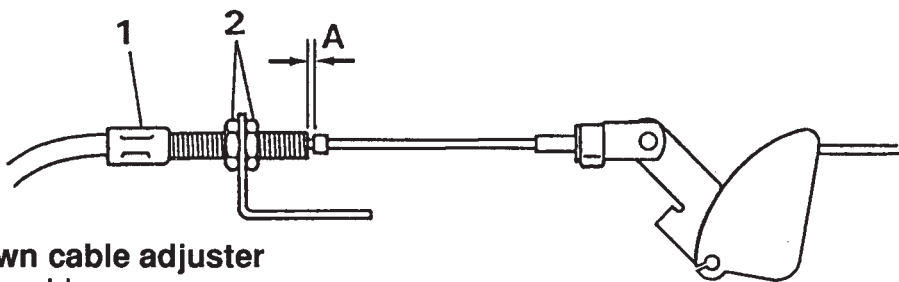

Fig.7 Kickdown cable adjuster

1. Outer cable
2. Lock nuts

1. Start the engine and run at idle speed.
2. Measure the crimp gap 'A' (fig.7); it should be 0,50 to 1,00 mm (0.020 to 0.040 in.).
3. If incorrect, slacken and adjust the lock nuts until the correct gap is achieved. Hold the outer cable while tightening the locknuts.
4. Re-check the crimp gap and re-adjust if necessary.

NOTE: If the crimp is correctly positioned on the inner cable and the cable assembly is routed correctly, gap 'A' should be 0,39 to 0,40 mm (0.0154 - 0.0157 in) when the accelerator is at the full throttle position (i.e. the resistance of the kick down cam can be felt).

ZF

STALL TESTING

Procedure

1. Connect an accurate tachometer to the engine.
2. Ensure that the transmission fluid is the correct type and to the correct level.
3. Chock all the road wheels securely and apply the hand and foot brakes.
4. Start the engine, select 'D' and depress the throttle fully for **NOT MORE THAN 5 SECONDS**. Note the maximum engine rpm reached on the tachometer.

CAUTION: If more than one test is required, allow 2 minute intervals between tests. After three tests, leave to cool for half an hour.

Analysis

Good Condition - stall test speed 2,000 rpm approx.

If the engine (see 'Engine Performance' below), torque converter and transmission are in good condition, the engine speed should reach but not exceed approximately 2,000 rpm.

Seized Stator - stall test speed 2,000 rpm approx. \pm 100 rpm.

The stall test will achieve the same engine speed (approximately 2,000 rpm). On road test, low speed acceleration will be correct, but higher road speed performance will be poor and top speed will be low.

Slipping Stator - stall test speed 1,000 rpm max.

The stall test engine rpm will be very low, maximum 1,000 rpm. On road test. acceleration will be poor but higher road speed performance and top speed will be correct.

Engine Performance - stall test speed 1,000 - 2,000 rpm.

The actual engine speed achieved by a stall test is very much dependent on engine condition. An engine in poor condition or badly tuned will reach a stall test speed of 1,000 to 2,000 rpm, assuming the torque converter and transmission are in good condition.

Transmission condition - stall test speed exceeds 2,000 rpm.

If during the stall test the engine speed exceeds 2,000 rpm and continues to rise, this indicates that a clutch is slipping.

NO FURTHER TESTING SHOULD BE CARRIED OUT UNTIL THE SLIP IS RECTIFIED.

