

# Service Workbook

## **XUD9A Engine**

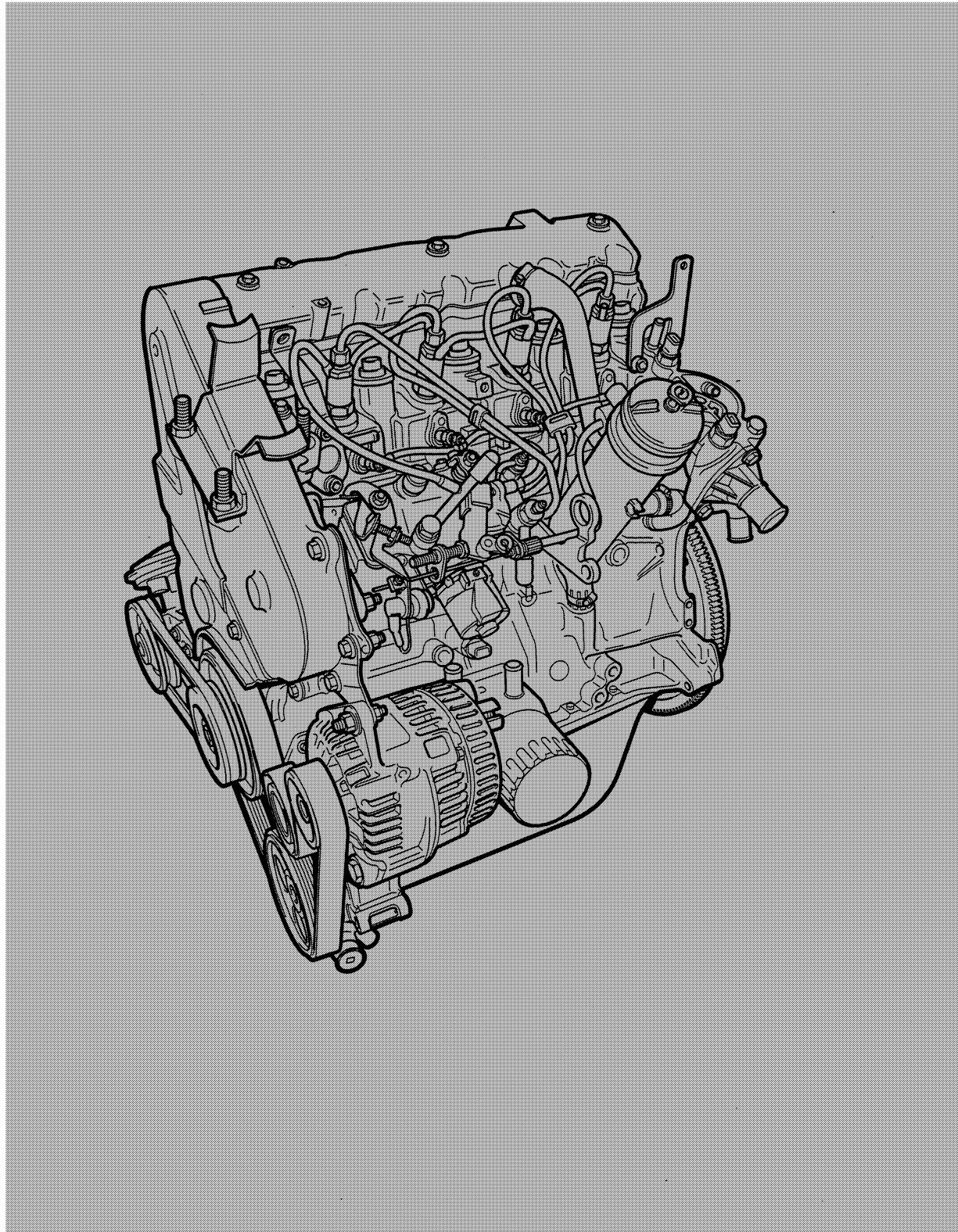



# XUD9A DIESEL ENGINE

## Service Workbook

This Service Workbook covers the XUD9A Diesel engine fitted to LDV vehicles. It is primarily designed to assist skilled technicians in the efficient repair and maintenance of this engine, but can also be used as a reference workbook for training purposes.

This Service Workbook should always be consulted prior to servicing or repair work.

### **SPECIFICATION**

LDV (the Company) reserves the right to change the procedures, material, specification, dimensions or design of the vehicles shown, described or referred to herein at any time and without prior notice in accordance with the Company's policy of constant product improvement.

Every reasonable effort is made to ensure that the Company's publications are accurate, but nothing shown, described or referred to herein should be regarded as an infallible guide to the procedures, materials, specifications, dimensions, design or availability of any particular vehicle, nor does this publication constitute an offer for the sale of any particular vehicle. No liability can be accepted by the Company or any Distributor or Dealer for any malfunction, damage, loss, injury, or death caused by the use of incorrect or misinterpreted information, omissions or errors that may have arisen during the preparation of this workbook.

Purchasers are advised that the specification details set out in this publication apply to a range of vehicles and not to any particular vehicle. For the specification of any particular vehicle, purchasers should consult their LDV Distributor or Dealer. Please note that LDV Distributors and Dealers are not agents of the Company, and have no right or authority whatsoever to bind the Company in any way, or to assume on its behalf any obligation expressed or implied.

### **COPYRIGHT**

© LDV 1994

All rights reserved. No part of this publication may be reproduced, stored in a retrieval system or transmitted, in any form, whether electronic, or mechanical, or by photocopying, recording or other means without prior permission in writing of LDV.

Published by LDV, from whom further copies may be obtained through your normal literature ordering procedure.

### **LDV Training & Publications**

Common Lane  
Washwood Heath  
Birmingham  
B8 2UP



## CONTENTS

	Page
Introduction and General Precautions .....	7
Technical data .....	9
Lubricants and Sealants .....	13
Service summary .....	15
Special tools .....	16
Torque wrench settings .....	19
Engine illustrations .....	20
<b>Engine:</b> – remove and refit .....	25
External drive belts – remove, refit, adjust .....	27
Alternator drive belt (models with power assisted steering) .....	27
Alternator drive belt (models without power assisted steering) .....	27
Vacuum pump drive belt .....	28
<b>Timing case:</b>	
Timing belt – remove .....	29
Crankshaft pulley and front oil seal – remove and refit .....	31
Timing belt – refit .....	32
<b>Cylinder head:</b>	
Camshaft pulley and oil seal – remove and refit .....	35
Tappet clearances check .....	39
– adjust .....	41
Cylinder head Remove .....	47
– Dismantling .....	50
– Inspection / overhaul .....	51
– Re-assembly .....	54
– Refit .....	56
<b>Flywheel:</b>	
Clutch – remove and refit .....	61
Crankshaft rear oil seal and spigot bearing – remove and refit .....	61
<b>Crankcase:</b>	
Dismantling .....	65
Inspection and overhaul	
– Cylinder block .....	67
– Crankshaft .....	67
– Pistons & connecting rods .....	68
Re-build .....	69

TORQUE WRENCH  
SETTINGS

ENGINE  
REMOVE / REFIT

TIMING CASE

CYLINDER HEAD

FLYWHEEL

CRANKCASE



LUBRICATION  
SYSTEM

FUEL SYSTEM

COOLING  
SYSTEM

HEATER PLUG  
SYSTEM

**Lubrication system:**  
Oil circulation ..... 77  
Oil pump – Inspection ..... 77

**Fuel system:**  
System operation ..... 78  
Injection pump adjustments  
    – Throttle cable ..... 79  
    – Idle speed ..... 80  
    – Automatic fast idle ..... 81  
    – Anti-stall ..... 82  
Injection pump timing – check and adjust ..... 83  
Injection pump – remove and refit ..... 87  
Injectors – remove, test and refit ..... 91  
Bleeding ..... 91

**Cooling system:**  
Coolant circulation ..... 93  
Coolant drain and refill ..... 93  
Cooling fans – testing ..... 93  
Water pump – remove and refit ..... 93  
Thermostat – remove and refit ..... 94

**Heater plug system:**  
System components ..... 96  
System operation ..... 97  
Heater plug testing ..... 97



## INTRODUCTION

**WARNINGS** and **CAUTIONS** are given throughout this Service Workbook in the following form:

**WARNING:** Procedures which must be followed precisely to avoid the possibility of personal injury

**CAUTION:** This calls attention to procedures which must be followed to avoid damage to components.

**NOTE:** This calls attention to methods which make a job easier to perform.

## REFERENCES

References to the left or right hand side in this Service Workbook are made when viewing the vehicle from the rear, unless instructed otherwise.

To reduce repetition, operations covered in this Service Workbook do not always include reference to testing the vehicle after repair. It is essential that work is inspected and tested after completion and, if necessary, a road test of the vehicle is carried out particularly where safety related items are concerned.

## GENERAL PRECAUTIONS

1. When disconnecting the vehicle battery, always disconnect the earth return (negative) cable first, and then the positive cable. On twin battery installations, disconnect both earth return (negative) cables first, and then the positive cables. When reconnecting the battery(s), connect the positive cable(s) first, then the negative cable(s).
2. Absolute cleanliness is essential when working on fuel injection components.
3. Always plug fuel injection system connectors when disconnected to avoid the possibility of dirt ingress.
4. Always turn the engine in a clockwise direction unless instructed otherwise.
5. The mating faces of all pulleys contained within the timing case must be assembled clean and dry.
6. Correct storage and handling of timing belts is most important, and the following points must be observed:
  - Timing belts must be stored flat and circular; never hang on a peg.
  - Do not crimp or bend to a diameter of less than 25 mm (1 in.).
  - A timing belt is constructed with a reinforcement of fibre running circumferentially inside it. Do not attempt to lever a belt on or off its pulleys as this may damage the fibres; use finger pressure only.
  - Before removing a belt which is to be re-used, identify its direction of rotation for refitment.
  - A belt must be renewed if contaminated with oil, fuel or other detrimental fluids. The pulleys must be cleaned if the belt has been contaminated, and the cause of the contamination identified and rectified.
  - Timing belt pulleys have a smooth finish to prolong belt life. Prior to fitting a belt, ensure the pulleys have no burrs or rough surfaces.



- Correct tensioning procedures are essential to ensure full service life of the belt.
  - During the time a timing belt is removed, to prevent damage to components it is important that neither crankshaft nor camshaft are turned unless instructed to do so.
7. Care must be taken when working underbonnet to avoid rotating pulleys and drive belts.
  8. Use only the approved LDV anti-freeze.

## **REPAIRS AND REPLACEMENTS**

When replacement parts are required, it is essential that only genuine LDV parts are used.



## DATA

### Engine

Type	10 CUA1, 4 cylinder in line	
Bore	83 mm	
Stroke	88 mm	
Capacity	1905 cm <sup>3</sup>	116.25 in <sup>3</sup>
Injection order (No.1 cylinder at flywheel end)	1 – 3 – 4 – 2	
Compression ratio	23 : 1	
Compression pressure (minimum)	25 – 30 bar	367 – 441 psi
Maximum compression pressure variation	5 bar	73.5 psi
Idle speed (minimum)	800 ± 50 RPM	
Anti-stall speed	900 ± 50 RPM	
Fast idle speed	950 ± 75 RPM	
Speed at maximum torque	2000 RPM	
Maximum governed speed	4600 RPM	
No load speed (maximum)	5100 RPM	

### Cylinder Head

Nominal height	157,40 – 157,75 mm		6.1968 – 6.2106 in.	
Max. permissible bow	0,07 mm		0.003 in.	
Max. permissible gasket face machining	0,40 mm		0.016 in.	
Valve guide bore	13,98 – 14,05 mm		0.5504 – 0.5531 in.	
– for 1st oversize guide	14,21 – 14,24 mm		0.5594 – 0.5606 in.	
– for 2nd oversize guide	14,51 – 14,54 mm		0.5713 – 0.5724 in.	
Inlet valve seat bore	40,00 – 40,20 mm		1.5748 – 1.5827 in.	
– for oversize insert	40,475 – 40,525 mm		1.5935 – 1.5955 in.	
Exhaust valve seat bore	34,00 – 34,20 mm		1.3389 – 1.3465 in.	
– for oversize insert	34,475 – 34,525 mm		1.3573 – 1.3592 in.	
Swirl chamber seat bore	diameter	32,00 – 32,20 mm	diameter	1.2598 – 1.2677 in.
	depth	3,90 – 4,00 mm	depth	0.1535 – 0.1575 in.
– for 1st oversize	diameter	32,40 mm	diameter	1.2756 in.
	depth	4,10 mm	depth	0.1614 in.
– for 2nd oversize	diameter	32,60 mm	diameter	1.2835 in.
	depth	4,20 mm	depth	0.1654 in.

### Camshaft

End float	0,025 – 0,114 mm	0.001 – 0.0045 in.
-----------	------------------	--------------------

### Valve Seats

Inlet valve seat angle	45°	
– Seat width (maximum)	2,45 mm	0.1 in.
– External diameter	40,19 – 40,36 mm	1.5823 – 1.589 in.
– Oversize	40,636 – 40.661 mm	1.5998 – 1.6008 in.
Exhaust valve seat angle	45°	
– Seat width (maximum)	3,00 mm	0.12 in.
– External diameter	34,14 – 34,34 mm	1.3441 – 1.352 in.
– Oversize	34,612 – 34,637 mm	1.3627 – 1.3637 in.



### Valve Guides

Internal diameter		8,02 – 8,22 mm	0.3157 – 0.3236 in.
External diameter		14,02 – 14,13 mm	0.552 – 0.5563 in.
– 1st oversize		14,279 – 14,29 mm	0.5622 – 0.5626 in.
– 2nd oversize		14,579 – 14,59 mm	0.5739 – 0.5744 in.
Fitted height above cylinder head face		36 – 37 mm	1.42 – 1.46 in.

### Inlet Valves

Seat angle		45°	
Maximum permissible refacing of seat		0,2 mm	0.008 in.
Stem diameter		8,005 mm	0.3152 in.
Head diameter		38,50 mm	1.5157 in.
Valve recession in head		0,5 – 1,05 mm	0.02 – 0.04 in.
Tappet clearance		0,15 ± 0,04 mm	0.006 ± 0.0015 in.

### Exhaust Valves

Seat angle		45°	
Maximum permissible refacing of seat		None	
Stem diameter		7,985 mm	0.3144 in.
Head diameter		33 mm	1.3 in.
Valve recession in head		0,9 – 1,45 mm	0.035 – 0.06 in.
Tappet clearance		0,30 ± 0,04 mm	0.012 ± 0.0015 in.

### Valve springs

Outside diameter		29 mm	1.14 in.
Free length		57 mm	2.24 in.
Underload length:			
304 – 336 N	(68 – 75 lbf)	42.4 mm	1.67 in.
522,5 – 577,5 N	(117 – 130 lbf)	33 mm	1.3 in.

### Swirl chamber

External diameter		32,05 – 32,25 mm	1.2618 – 1.2697 in.
Flange thickness		4,00 – 4,10 mm	0.1575 – 0.1614 in.
– for 1st oversize	diameter	32,45 mm	1.2776 in.
	flange thickness	4,20 mm	0.1654 in.
– for 2nd oversize	diameter	32,65 mm	1.2854 in.
	flange thickness	4,30 mm	0.1693 in.

### Cylinder block

Cylinder bore diameters			
Standard size Identification	None	83,00 – 83,018 mm	3.2677 – 3.2684 in.
	A1	83,03 – 83,048 mm	3.2689 – 3.2696 in.
Oversize	R1	83,20 – 83,218 mm	3.2756 – 3.2763 in.
	R2	83,50 – 83,518 mm	3.2874 – 3.2881 in.
	R3	83,80 – 83,818 mm	3.2992 – 3.2999 in.





## Pistons

### Piston diameters

Standard size	Identification	None	82,93 ± 0,009 mm	3.2649 ± 0.0003 in.
		A1	82,96 ± 0,009 mm	3.2661 ± 0.0003 in.
Oversizes		R1	83,13 ± 0,009 mm	3.2728 ± 0.0003 in.
		R2	83,43 ± 0,009 mm	3.2846 ± 0.0003 in.
		R3	83,73 ± 0,009 mm	3.2964 ± 0.0003 in.
Piston ring gaps	Top ring		0,20 – 0,40 mm	0.008 – 0.016 in.
	2nd ring		0,15 – 0,35 mm	0.006 – 0.014 in.
	Oil control ring		0,10 – 0,30 mm	0.004 – 0.012 in.
Gudgeon pin	diameter		25.00 mm	0.9842 in.

## Connecting Rods

Big end bearing oversize	+ 0,15 mm	+ 0.006 in.
Small end bush internal dia. (after reaming)	25,007 – 25,02 mm	0.9845 – 0.9850 in.

## Crankshaft

Main journal diameter	59,981 – 60,00 mm	2.3614 – 2.3622 in.	
Main journal dia. (for undersize bearings)	59,681 – 59,70 mm	2.3496 – 2.3504 in.	
Big end crankpin diameter	49,984 – 50,00 mm	1.9679 – 1.9685 in.	
Big end crankpin dia. (for undersize bearings)	49,684 – 49,70 mm	1.9561 – 1.9567 in.	
Crankshaft end–float	0,07 – 0,32 mm	0.003 – 0.012 in.	
No.2 main journal width	1st oversize	26,60 ± 0,05 mm	1.0472 ± 0.002 in.
	2nd oversize	26,80 ± 0,05 mm	1.0551 ± 0.002 in.
	3rd oversize	26,90 ± 0,05 mm	1.0591 ± 0.002 in.
	3rd oversize	27,00 ± 0,05 mm	1.063 ± 0.002 in.
End float thrust washer thickness	1st oversize	2,305 ± 0,025 mm	0.9075 ± 0.001 in.
	2nd oversize	2,405 ± 0,025 mm	0.0947 ± 0.001 in.
	3rd oversize	2,455 ± 0,025 mm	0.0967 ± 0.001 in.
	3rd oversize	2,505 ± 0,025 mm	0.0986 ± 0.001 in.
Rear oil seal contact surface diameter	89,913 – 90,00 mm	3.5399 – 3.5433 in.	
Minimum diameter after machining	89,713 – 89,80 mm	3.532 – 3.5354 in.	

## Flywheel

Maximum permissible radial run–out	0,15 mm	0.006 in.
Maximum permissible axial run–out	0,10 mm	0.004 in.

## Fuel System

Fuel injection pump	Lucas CAV rotary	
Type	DPC 8443B952B	
Static timing	See figure on pump	
Dynamic timing	12°	BTDC AT IDLE (ENGINE HOT)
Fuel injectors	Lucas CAV	
Type	LCR	
Body	LCR 3735201D	
Nozzle	LCRRDNOSDC6887D	
Injection pressure	125 ± 5 bar	1812.5 ± 75 psi



### Heater plugs

Make	Bosch
Voltage	11 volts
Tip starts to glow	3 seconds
Initial current draw	25 amps
Current draw after 20 seconds	12 amps

### Vacuum pump

Make	Saginaw
Minimum vacuum	560 mm Hg at idle speed for 2 minutes

### Lubrication System

Filter	Full flow, disposable		
Oil pressure	– at 800 RPM	1.6 bar	23 psi
	– at 4000 RPM	3,5 bar	50 psi
Warning light switch pressure	0,5 bar		7 psi
Oil cooler	Water cooled, Modine		

### Cooling System

Pressure cap setting	1 bar
Thermostat opening temperature	83°C

### Clutch

Type	Single dry plate	
Clutch plate diameter	215 mm	8.46 in



## LUBRICANTS

MULTIPART Multigrade Super 15W 40

Engine refill and filter change	5,2 litres	(9.15 pints)
Dipstick 'MIN' and 'MAX'	1 litre	(1.78 pints)

Oils must conform to specification CCMC PD2 or RES.22.OL PD2.

## COOLANT

Capacity	10.6 litres	(18.66 pints)
----------	-------------	---------------

Only approved anti-freeze must be used for this engine, and the correct coolant proportions are 50% anti-freeze, 50% water.

1 litre	Part no. BBU 9320
5 litres	BBU 9319

## SEALANTS

Crankshaft front oil seal housing	Loctite 518	Part no. BBU 8377
Contact area of rear main bearing cap.	Loctite 518	BBU 8377
Cam cover, front / rear inboard contact areas.	Loctite 518	BBU 8377
Contact area, front / rear camshaft caps	Loctite 518	BBU 8377
Crankshaft damper bolt	Loctite 270	ACU 1557
Oil cooler securing bolt	Loctite 270	ACU 1557
Cylinder head bolt threads	Molycote G Rapid	
Sump	Rhodoseal 5661	100 ml - BBU 9422 350 ml - BBU 9423



**SERVICE SUMMARY**

	<b>MILEAGE</b>				
	<b>1,000</b>	<b>6,000</b>	<b>12,000</b>	<b>24,000</b>	<b>48,000</b>
<b>RENEW ENGINE OIL &amp; FILTER</b>	●	●	●	●	●
<b>DRAIN WATER FROM FUEL FILTER</b>	●	●			
<b>RENEW FUEL FILTER</b>			●	●	●
<b>VISUALLY CHECK ALTERNATOR/ POWER STEERING &amp; VACUUM PUMP BELTS FOR CONDITION &amp; TENSION</b>			●	●	<b>RENEW BOTH BELTS</b>
<b>CHECK CONDITION OF TIMING BELT</b>			●	●	<b>RENEW BELT</b>
<b>CHECK COOLANT LEVEL &amp; INSPECT HOSES/CONNECTIONS FOR LEAKS. CHECK ANTI-FREEZE SOLUTION STRENGTH (50%)</b>			●	<b>RENEW COOLANT</b>	<b>RENEW COOLANT</b>
<b>CHECK COOLING FAN OPERATION</b>	●	●	●	●	●
<b>RENEW AIR FILTER</b>				●	●
<b>VISUALLY CHECK CRANKCASE BREATHER SYSTEM FOR LEAKS, HOSES FOR SECURITY &amp; CONDITION</b>			●	●	●



## SPECIAL TOOLS

18G 1627A

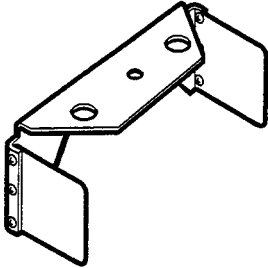

• Crankshaft cap oil seal replacer

18G 1628A

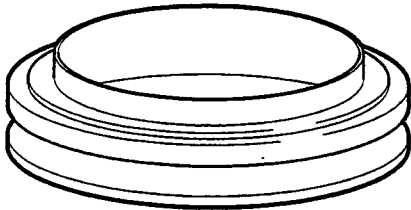

• Crankshaft rear main oil seal replacer

LDV 101

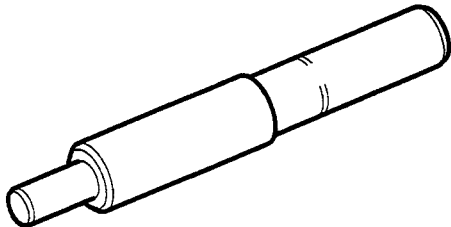

• Clutch centraliser

LDV 102

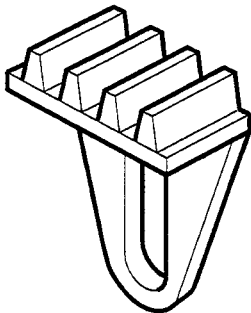

• Flywheel locking tool

LDV 103

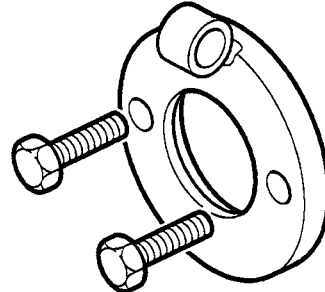

• Fuel injection pump pulley remover

LDV 104

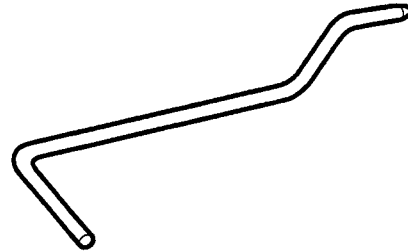

• Flywheel timing pin

0480028 (18G 1508)

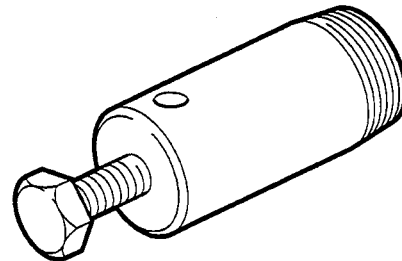

Seal remover

0480039 (FR 1509)

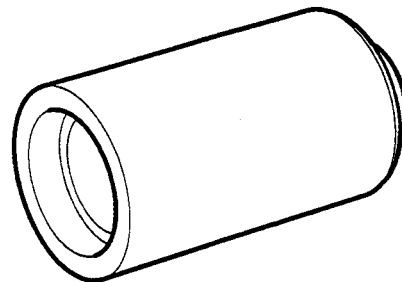

Seal replacer

• NEW TOOLS INTRODUCED FOR THIS ENGINE

0480054 (18G 1205)

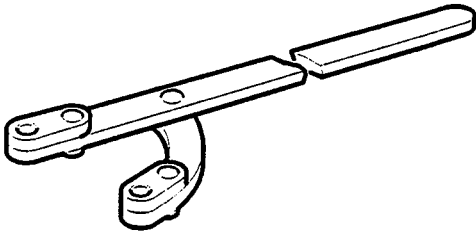

Flange holder

1210504 (18G 1507)

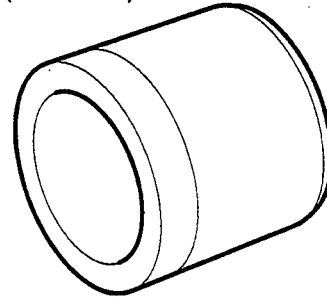

Seal replacer

0480059 (MS 1501)

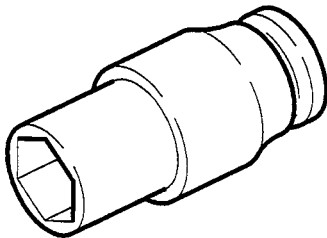

Injector socket

1210507 (18G 1519A)

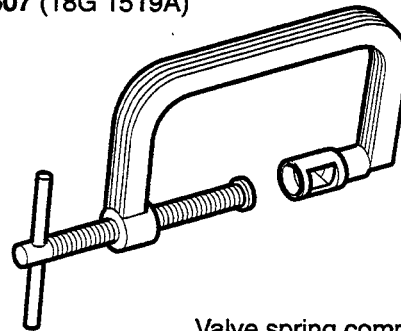

Valve spring compressor

0480066

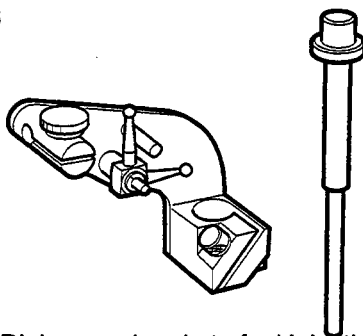

Dial gauge bracket, fuel injection pump

0480080 (LST 122)

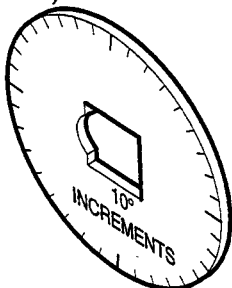

Angular torque gauge



## DIAGNOSTIC TOOLS

0484976 (DX 710)

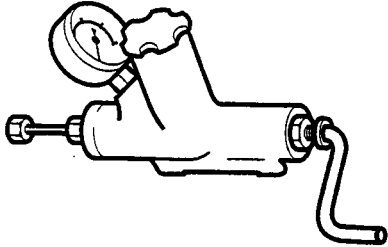

Injector tester

1210515 (DX 900)

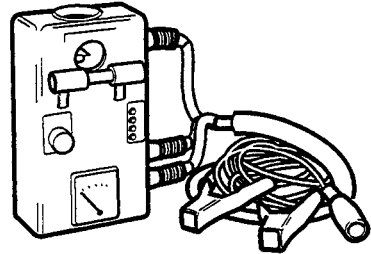

Heater plug tester

1210513 (DX 511)

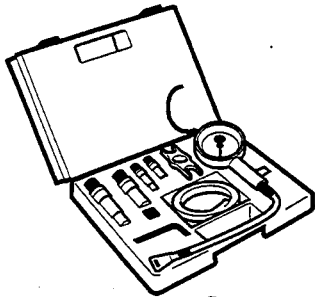

Compression tester

1210524 (DX 801)

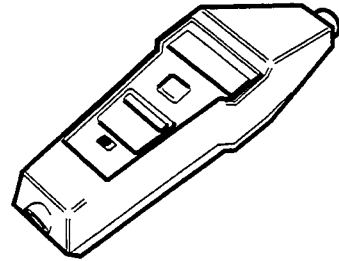

Optical tachometer



## TORQUE WRENCH SETTINGS

Component			Nm	Lbf ft
Air box to manifold bolts			10	7
Camshaft bearing cap nuts			17,5	13
Camshaft cover bolts			10	7
Camshaft pulley nut			40	30
Clutch securing bolts			25	18
Conn. rod big end nuts	1st stage	pre-tighten	20 ± 2	15 ± 1.5
	2nd stage	tighten	70° ± 5°	70° ± 5°
	3rd stage	check	50 ± 10	37 ± 7
Crankshaft front oil seal housing bolts			15	11
Crankshaft main bearing cap bolts			70	52
Crankshaft damper			40+ 60°	30+60°
Cylinder head bolts	1st stage	pre-tighten	15-20	11-15
	2nd stage	tighten	55-65	40-48
	3rd stage	tighten	180°	180°
Exhaust manifold			20	15
Flywheel bolts			50	37
Fuel injection pump pulley nut			50	37
Glow plugs			22	16
Injectors			90	66
Inlet manifold bolts			22.5	17
Oil cooler fixing			57.5	42
Oil drain plug			25	18
Oil pump bolts			20	15
Starter motor securing bolts			35	26
Sump bolts			20	15
Timing belt tensioner			15	11
Water pump			15	11



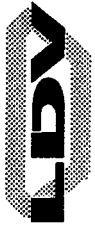

EXTERNAL COMPONENTS

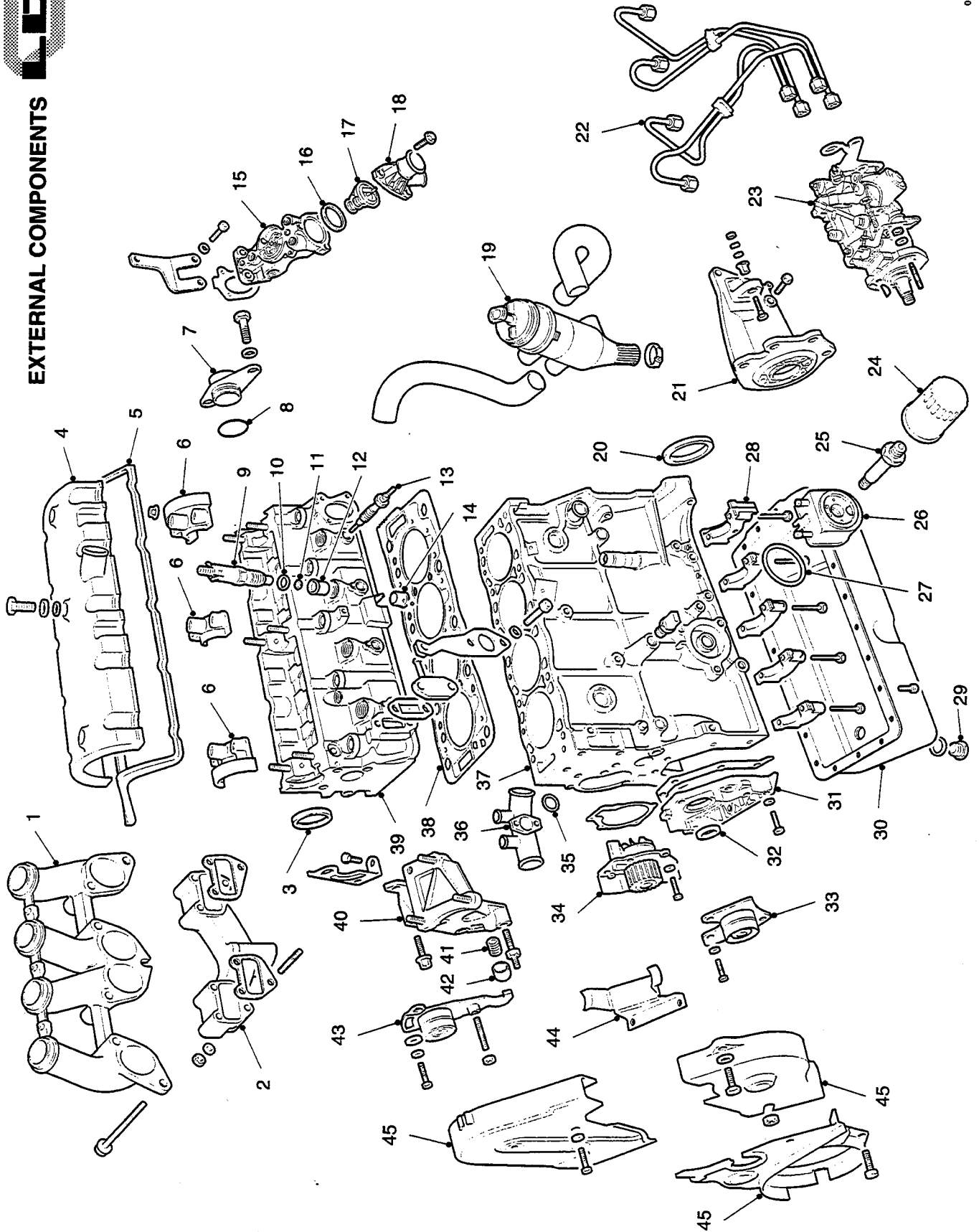

## EXTERNAL COMPONENTS

- |     |                                 |                           |  |
|-----|---------------------------------|---------------------------|--|
| 1.  | Inlet manifold                  |                           |  |
| 2.  | Exhaust manifold                |                           |  |
| 3.  | Camshaft oil seal               |                           |  |
| 4.  | Camshaft cover                  |                           |  |
| 5.  | Seal                            |                           |  |
| 6.  | Camshaft bearing caps           |                           |  |
| 7.  | Rear cover                      |                           |  |
| 8.  | 'O' ring                        |                           |  |
| 9.  | Injector                        |                           |  |
| 10. | Copper washer                   |                           |  |
| 11. | Heat shield washer              |                           |  |
| 12. | Injector shroud                 |                           |  |
| 13. | Heater plug                     |                           |  |
| 14. | Swirl chamber                   |                           |  |
| 15. | Thermostat housing              |                           |  |
| 16. | Seal                            |                           |  |
| 17. | Thermostat                      |                           |  |
| 18. | Thermostat cover                |                           |  |
| 19. | Oil filler                      |                           |  |
| 20. | Crankshaft rear oil seal        |                           |  |
| 21. | Injection pump mounting bracket |                           |  |
| 22. | Injector pipes                  |                           |  |
| 23. | Fuel injection pump             |                           |  |
| 24. | Oil filter                      |                           |  |
| 25. | Oil cooler fixing               |                           |  |
| 26. | Oil cooler                      |                           |  |
| 27. | Sealing ring                    |                           |  |
| 28. | Main bearing cap                |                           |  |
| 29. | Drain plug                      |                           |  |
| 30. | Sump                            |                           |  |
| 31. |                                 | Oil seal housing          |  |
| 32. |                                 | Oil seal                  |  |
| 33. |                                 | Idler                     |  |
| 34. |                                 | Water pump                |  |
| 35. |                                 | 'O' ring                  |  |
| 36. |                                 | Coolant manifold          |  |
| 37. |                                 | Cylinder block            |  |
| 38. |                                 | Cylinder head gasket      |  |
| 39. |                                 | Cylinder head             |  |
| 40. |                                 | Tensioner plunger housing |  |
| 41. |                                 | Tensioner spring          |  |
| 42. |                                 | Tensioner plunger         |  |
| 43. |                                 | Tensioner                 |  |
| 44. |                                 | Belt inspection plate     |  |
| 45. |                                 | Timing covers             |  |



## INTERNAL COMPONENTS

- |     |                               |                          |  |
|-----|-------------------------------|--------------------------|--|
| 1.  | Timing belt                   |                          |  |
| 2.  | Bolt                          |                          |  |
| 3.  | Washer                        |                          |  |
| 4.  | Camshaft pulley               |                          |  |
| 5.  | Oil seal                      |                          |  |
| 6.  | Key                           |                          |  |
| 7.  | Camshaft                      |                          |  |
| 8.  | Tappet                        |                          |  |
| 9.  | Shim                          |                          |  |
| 10. | Valve collets                 |                          |  |
| 11. | Spring cap                    |                          |  |
| 12. | Oil seal                      |                          |  |
| 13. | Spring                        |                          |  |
| 14. | Spring seat                   |                          |  |
| 15. | Fuel injection pump pulley    |                          |  |
| 16. | Nut                           |                          |  |
| 17. | Valve guide                   |                          |  |
| 18. | Exhaust valve seat            |                          |  |
| 19. | Exhaust valve                 |                          |  |
| 20. | Inlet valve                   |                          |  |
| 21. | Inlet valve seat              |                          |  |
| 22. | Bolt                          |                          |  |
| 23. | Washer                        |                          |  |
| 24. | Vacuum pump pulley            |                          |  |
| 25. | Crankshaft damper pulley      |                          |  |
| 26. | Crankshaft timing belt pulley |                          |  |
| 27. | Oil pump drive sprocket       |                          |  |
| 28. | Keys                          |                          |  |
| 29. | Oil pump drive chain          |                          |  |
| 30. | Oil pump                      |                          |  |
| 31. | Thrust washers—lower half     |                          |  |
| 32. | Main shell bearing            |                          |  |
| 33. |                               | Big end bearing cap      |  |
| 34. |                               | Big end shell bearing    |  |
| 35. |                               | Spigot bush              |  |
| 36. |                               | Dowel pin                |  |
| 37. |                               | Flywheel                 |  |
| 38. |                               | Thrust washer—upper half |  |
| 39. |                               | Crankshaft               |  |
| 40. |                               | Connecting rod           |  |
| 41. |                               | Small end bush           |  |
| 42. |                               | Snap ring                |  |
| 43. |                               | Gudgeon pin              |  |
| 44. |                               | Oil control ring         |  |
| 45. |                               | Compression ring         |  |
| 46. |                               | Compression ring         |  |

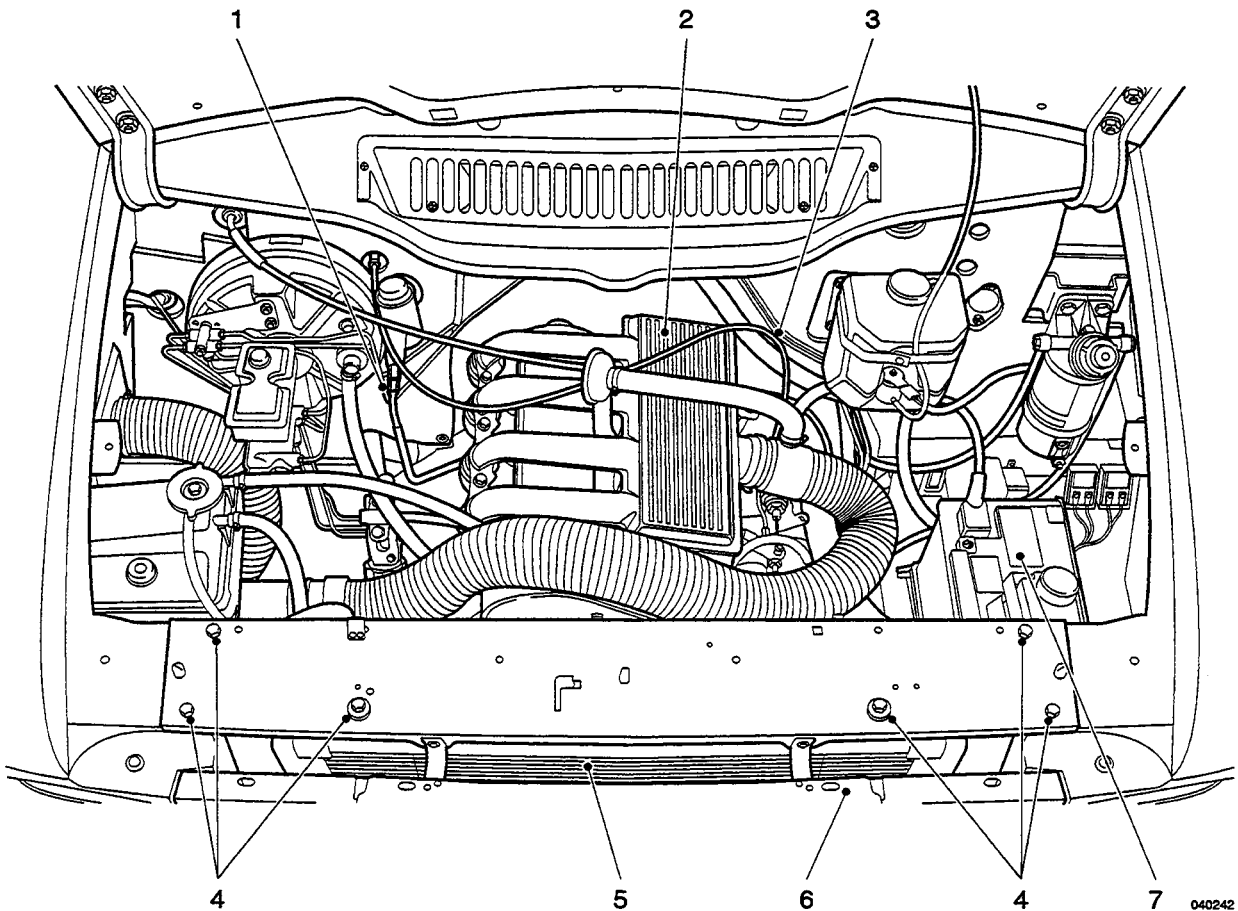

**Fig.1 XUD9A engine compartment**

- |                            |                    |
|----------------------------|--------------------|
| 1. Clutch pipe             | 5. Radiator        |
| 2. Air box                 | 6. Radiator grille |
| 3. Throttle cable          | 7. Battery         |
| 4. Bonnet closing platform |                    |

**ENGINE REMOVE AND REFIT**

**Remove**

1. Disconnect the battery(s), negative terminal(s) first.
2. **WARNING: USE CAUTION IF THE COOLANT IS HOT.**  
Drain the cooling system, by removing the bottom radiator hose at the coolant manifold
3. Remove the air box and intake air duct.
4. Remove:
  - Bonnet.
  - Radiator grille
  - Bonnet locking platform.
5. Disconnect coolant hoses as necessary.
6. Remove the radiator and fan assembly.
7. Disconnect:
  - Clutch pipe from master cylinder.
  - Engine earth strap at the body.
  - Throttle cable.
  - All electrical connections to the engine.
  - Fuel lines connected to the engine; plug all connections.



8. Under the vehicle Disconnect:
  - Propeller shaft at gearbox flange (mark flange for re-alignment).
  - Speedometer drive at gearbox.
  - Reverse lamp cables.
9. Remove the gearchange mechanism.
10. Support the rear of the gearbox and remove the gearbox crossmember.
11. **WARNING: USE CAUTION IF THE EXHAUST PIPE IS HOT.**  
Detach the exhaust downpipe from the manifold and from the bellhousing bracket.
12. Remove the vacuum pump, and the power assisted steering pump (if fitted).
13. Attach lifting equipment and take the weight of the engine.
14. Remove the engine crossmember.
15. Suitably support the rear of the gearbox and manoeuvre the engine and gearbox assembly out of the vehicle.
16. **WARNING: THE GEARBOX MOUNTING PLATE IS HEAVY AND IS LOCATED TO THE CYLINDER BLOCK ON DOWEL PINS WHEN THE GEARBOX IS REMOVED. DO NOT ALLOW THE PLATE TO BE DISPLACED INADVERTENTLY.**  
Remove the gearbox and remove the gearbox mounting plate, or temporarily secure it with a suitable bolt.

## Refit

Refitting is the reverse of the removal procedure, but note the following points:

- Align the marks made during removal and engage the propeller shaft on the gearbox flange bolts before raising the gearbox to fit the crossmember.
- Apply Loctite 270 to the propeller shaft flange bolt threads.
- Bleed the fuel system.
- Bleed the clutch hydraulics.
- Adjust the throttle cable as necessary (see section 'Fuel Injection Pump Adjustments').
- Refill with coolant (50% anti-freeze) to the correct level.
- Check the oil level and top up as necessary.
- When fitted, start the engine and run until normal operating temperature is reached. Check for leaks.

**WARNING: PLACE A THICK CLOTH OVER THE CAP AND EXPANSION TANK BEFORE ATTEMPTING TO REMOVE THE CAP SLOWLY, TO AVOID THE POSSIBILITY OF SCALDING IF THE ENGINE IS HOT.**

Check the coolant level and top up as necessary.

## EXTERNAL DRIVE BELTS

Remove, Refit, Adjust

**WARNING: DO NOT ATTEMPT TO CHECK BELT TENSION OR MAKE BELT ADJUSTMENTS WITH THE ENGINE RUNNING. SERIOUS INJURY COULD RESULT.**

### ALTERNATOR DRIVE BELT

Models with power assisted steering

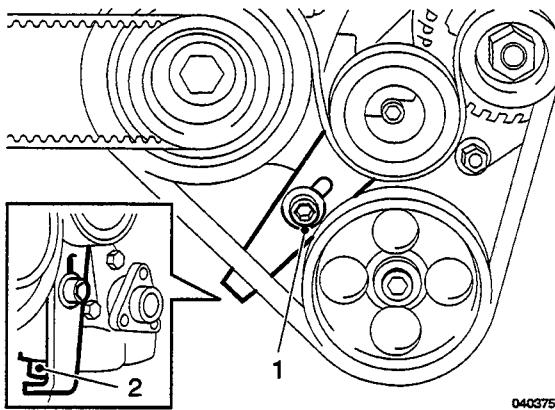

**Fig.1 Belt tension adjustment**

1. Security bolt
  2. Tensioner bolt
1. Slacken the belt tensioner security bolt. Release belt tension by slackening the tensioner bolt.
  2. Remove the belt. If not due for renewal, examine for wear, damage, cracks etc. and renew if necessary.
  3. Fit the belt.
  4. Tighten the tensioner bolt until the belt deflection is 6 mm (1/4 in.) at the mid point of the longest run. Tighten the security bolt.
  5. **CAUTION: It is essential that drive belts are correctly fitted.**  
If a new belt has been fitted, start the engine and run at 1,000 rpm for 5 minutes. Then stop the engine and check the belt tension, re-adjusting if necessary.

Models without power assisted steering

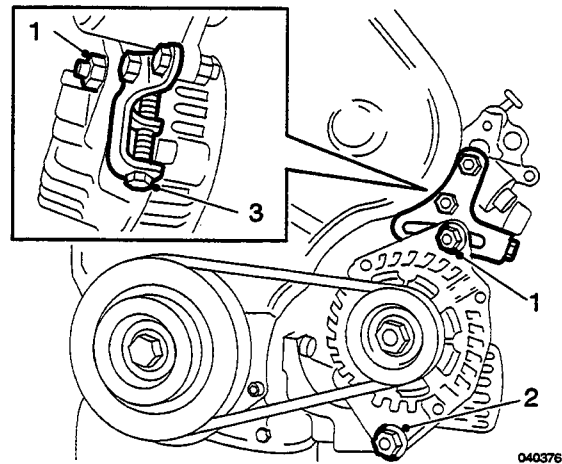

**Fig.2 Belt tension adjustment**

1. Tensioner bracket securing nut
  2. Alternator pivot bolt
  3. Tensioner bolt
1. Slacken the belt tensioner bracket securing nut and the alternator pivot bolt.
  2. Release belt tension by slackening the tensioner bolt, and remove the belt.
  3. If not due for renewal, examine the belt for wear, damage, cracks etc. and renew if necessary.
  4. Fit the belt.
  5. Tighten the tensioner bolt until the belt deflection is 6 mm (1/4 in.) at the mid point of the belt run, then tighten the alternator pivot bolt and the tensioner bracket securing nut.
  6. **CAUTION: It is essential that drive belts are correctly fitted.**  
If a new belt has been fitted, start the engine and run at 1,000 rpm for 5 minutes. Then stop the engine and check the belt tension, re-adjusting if necessary.

**ENGINE  
REMOVE/REFIT**



## VACUUM PUMP DRIVE BELT

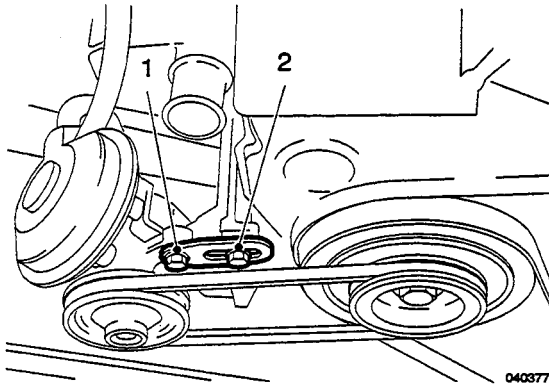

ENGINE  
REMOVE / REFIT

**Fig.3 Belt tension adjustment**

1. Tensioner bracket securing nut
  2. Tensioner adjustment bolt
1. Slacken the belt tensioner bracket securing nut and the adjustment bolt.
  2. Push the vacuum pump inwards and remove the drive belt.
  3. If not due for renewal, examine the belt for wear, damage, cracks etc. and renew if necessary.
  4. Fit the belt.
  5. Pivot the pump outwards, and tighten the adjuster nut and securing bolt when there is a belt deflection of 6 mm (1/4 in.) at the mid point of the belt run.
  6. **CAUTION: It is essential that drive belts are correctly fitted.**  
If a new belt has been fitted, start the engine and run at 1,000 rpm for 5 minutes. Then stop the engine and check the belt tension, re-adjusting if necessary.



## TIMING CASE

### TIMING BELT REMOVE & REFIT

Tools required: 0480066, LDV 102, LDV 104.

#### TIMING BELT – Remove

The timing belt can be removed with the engine in situ after first carrying out the following operations.

**NOTE:** Components at the front of the engine (e.g. pulleys, crankshaft front oil seal, water pump etc.) can be accessed after removing the timing belt.

1. Disconnect the battery(s), negative (earth) terminal(s) first.
2. Detach the intake air duct.
3. Drain the coolant, and disconnect radiator hoses and cables to fans.
4. Remove the radiator grille, bonnet locking platform and radiator complete with fans.
5. Remove the external drive belts.
6. Restrain the crankshaft from turning (flywheel locking tool LDV 102 can be used for this purpose), and remove the crankshaft damper. Remove the flywheel locking tool.

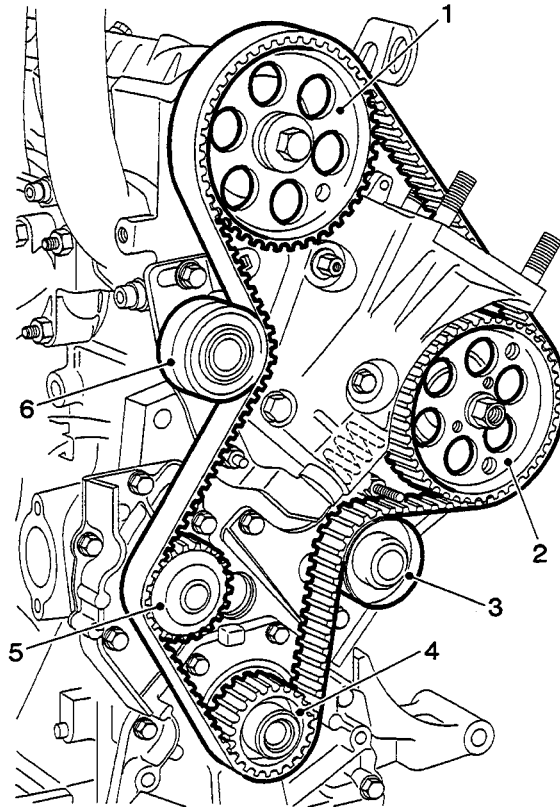

040244

TIMING CASE

**Fig.1 Timing pulleys**

1. Camshaft pulley
  2. Fuel injection pump pulley
  3. Idler roller
  4. Crankshaft pulley
  5. Water pump pulley
  6. Timing belt tensioner roller
7. Remove the timing belt inspection plate and the 3-part timing covers.

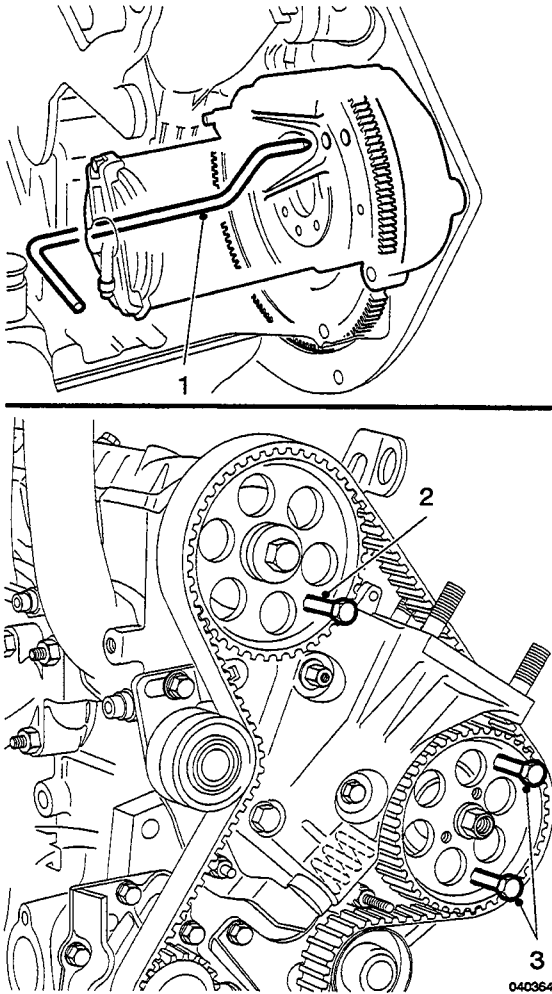

**Fig.2 Fitting timing pin and timing bolts**

1. Flywheel timing pin LDV 104.
  2. Camshaft timing bolt.
  3. Injection pump timing bolts.
8. Turn the crankshaft clockwise until no.4 cylinder (front of engine) is at TDC firing position. Fit the timing pin LDV 104 in the flywheel location. Fit suitable length M8 bolts in the camshaft pulley and fuel injection pump pulley timing holes, finger tight only.

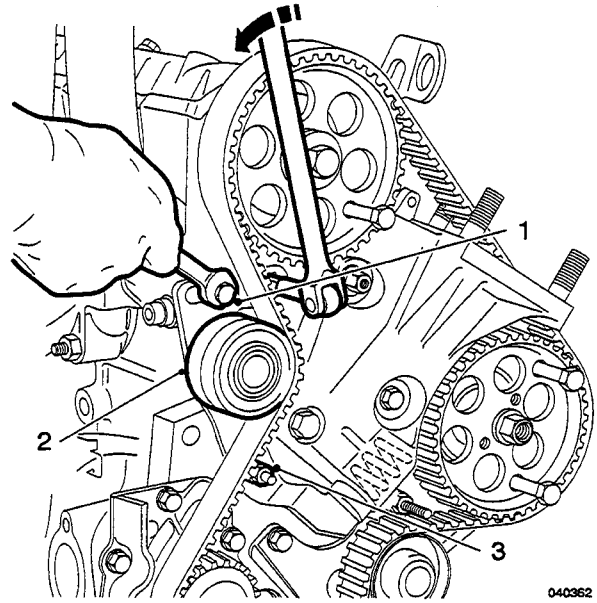

**Fig.3 Releasing timing belt tension**

1. Tensioner securing bolt
  2. Tensioner roller
  3. Tensioner securing nut
9. Slacken the belt tensioner securing nut and bolt. Release the belt tension by pulling the tensioner roller fully away from the belt against spring pressure, and tighten the securing bolt.

**NOTE:** A square drive hole is provided in the tensioner bracket to facilitate this.

**10. CAUTION:**

1. Unless instructed, do not turn the camshaft or crankshaft when the timing belt is not fitted.
2. If the belt is contaminated it must be changed and all pulleys cleaned.
3. Do not contaminate the pulleys when handling them.

If the timing belt is to be re-used, mark its direction of rotation with chalk then remove the belt.

**NOTE:** The camshaft pulley, fuel injection pump pulley, tensioner, plunger housing, idler assembly and the water pump can now be removed if required.

11. Examine all pulleys for wear, damage and contamination. Clean or renew as necessary.

To refit and tension the timing belt, check the fuel injection timing and re-build the engine, see section 'Timing Belt Refit'.

### CAMSHAFT PULLEY

**NOTE:** The camshaft pulley and oil seal can be removed / refitted at this stage if desired, but for specific procedures see section 'Cylinder head'.

### FUEL INJECTION PUMP PULLEY

**NOTE:** The fuel injection pump pulley can be removed / refitted at this stage if desired, but for specific procedures see section 'Fuel Injection Pump Remove and Refit'.

### CRANKSHAFT PULLEY AND FRONT OIL SEAL

#### Remove and Refit

**Tools required:** 0480066, LDV 102, LDV 104, 1210504 (18G 1507).

Remove the timing belt (see section 'Timing Belt Remove').

12. Remove the crankshaft pulley, and recover the loose key.

**NOTE:** On chassis cab vehicles, if this work is being carried out in situ, it may first be necessary to disconnect the engine mountings and lift the engine to provide sufficient clearance for the pulley to be removed.

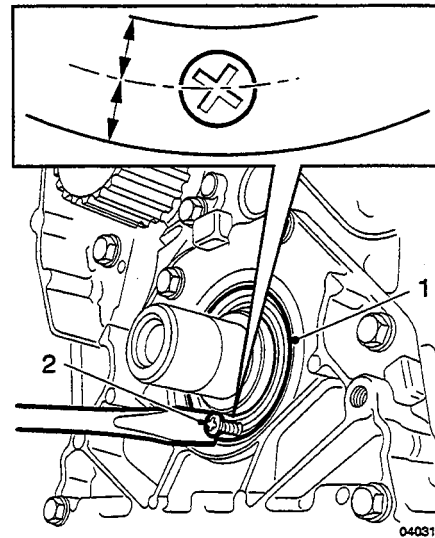

**Fig.4 Removing crankshaft front oil seal**

1. Oil seal
2. Self tapping screw

13. Extract the oil seal as follows:
 

**CAUTION: Do not allow the drill to penetrate too far and cause damage to the oil pump drive chain or its sprocket.**

  - Carefully drill a 3 mm hole in the position illustrated.
  - Fit a suitable self-tapping screw in the hole to a depth of no more than 6 mm (1/4 in.), and use it to prise out the seal as illustrated.
  - Clean out any swarf or dirt.

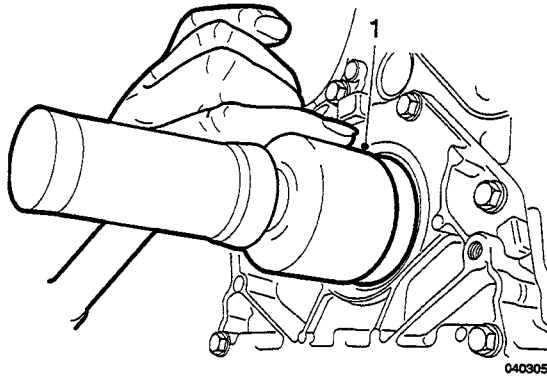

**Fig.5 Fitting crankshaft oil seal**

1. 1210504 (18G 1507)

14. Lubricate the lip of the new seal, then position with its garter spring towards the rear of the engine. Use tool 1210504 (18G 1507) to tap the seal into place until it is flush with the front face of the housing.
15. Fit the crankshaft pulley with its key.  
Fit and tension the timing belt, check the fuel injection pump timing and rebuild the engine (see section 'Timing Belt Refit').

**TIMING CASE**

**TIMING BELT – Refit**

16. If removed, fit:
  - Idler roller assembly
  - Water pump (use new gasket)
  - Tensioner plunger housing; check that plunger has free movement in housing.
  - Tensioner with its plunger and spring.
17. If previously disturbed, tighten the tensioner nut and bolt with the plunger spring fully compressed.
18. Check that the crankshaft remains at TDC (flywheel timing pin fitted), and that the camshaft and fuel injection pump are in their timing position (timing bolts fitted).

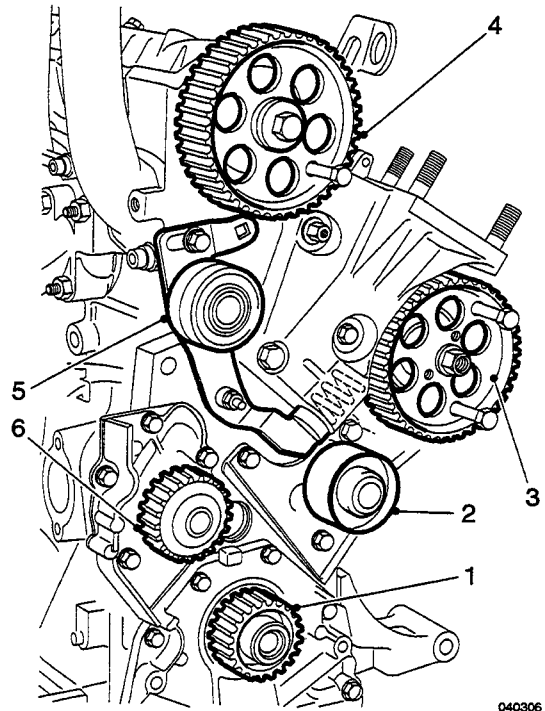

**Fig.6 Timing pulleys**

1. Crankshaft pulley
  2. Idler roller
  3. Fuel injection pump pulley
  4. Camshaft pulley
  5. Tensioner assembly
  6. Water pump pulley
19. Check the direction-of-rotation mark made during removal if re-fitting the old timing belt. If fitting a new belt, ensure that the printing on the belt can be read from the front. To fit the belt start at the crankshaft pulley, and then fit it round the other pulleys in the following sequence, keeping its run taut.
    - Crankshaft pulley
    - Idler roller
    - Fuel injection pump pulley
    - Camshaft pulley
    - Tensioner roller
    - Water pump pulley.
  20. Remove the timing bolts and the flywheel timing pin LDV 104.

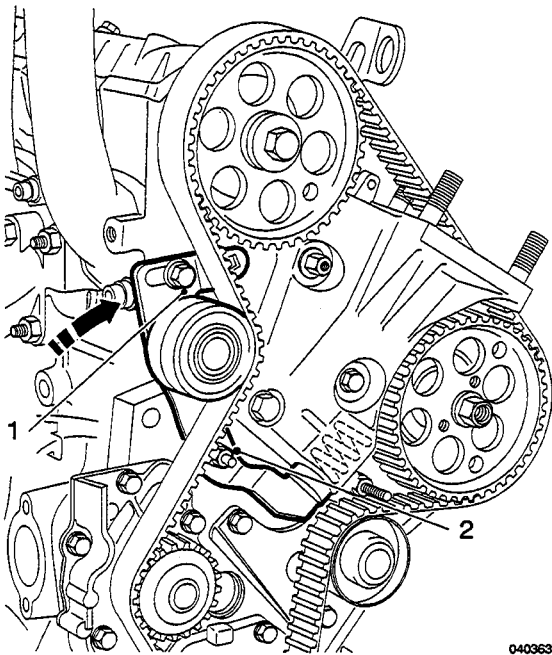

040363

**Fig.7 Timing belt adjuster**

1. Tensioner bolt
2. Tensioner nut

21. Slacken the tensioner securing bolt and nut by two turns, and allow the spring and plunger to self-tension the timing belt.

Temporarily tighten the bolt and nut.

22. Fit the lower timing cover. Fit the crankshaft damper, and tighten its securing bolt finger tight.

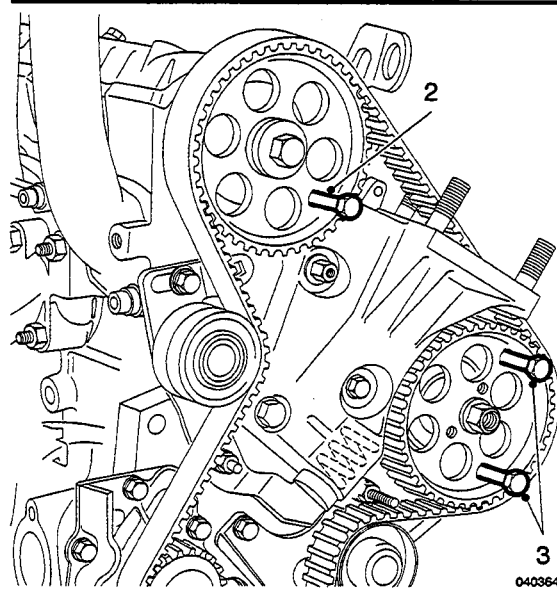
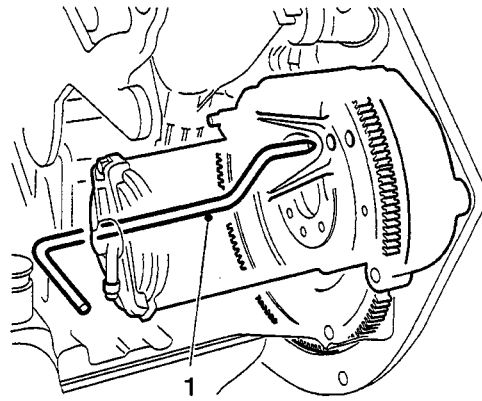

040364

**Fig.8 Fitting timing pin and timing bolts**

1. Flywheel timing pin LDV 104.
2. Camshaft timing bolt.
3. Injection pump timing bolts.

23. Turn the crankshaft clockwise 7 complete turns, then continue turning until the flywheel timing pin LDV 104 can be fitted, together with the camshaft and injection pump timing bolts.

**NOTE:** If it is not possible to fit all the timing pins / bolts, the timing belt fitting procedure has not been carried out correctly and must be repeated.

**NOTE:** Do not turn the crankshaft anti-clockwise.

24. Slacken the tensioner nut and bolt by two turns, and allow the spring and plunger to re-tension the timing belt. Then tighten the bolt and the nut to the correct torque.

25. Remove the camshaft and fuel injection pump timing bolts, and the flywheel timing pin LDV 104.

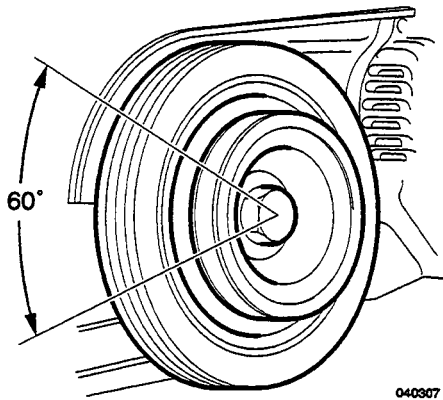

**Fig.9 Tightening crankshaft damper**

26. Secure the crankshaft damper as follows:

- Fit the flywheel locking tool LDV 102.
- Carefully degrease and clean the bolt threads, bolt head, bearing faces of washer and the threaded hole in the crankshaft.
- Coat bolt threads with Loctite 270.
- Torque tighten bolt to 40 Nm (30 lbf ft).
- Tighten bolt a further 60°.
- Remove the flywheel locking tool.

27. Check the fuel injection pump timing as described in the section 'Fuel System'.

**NOTE:** This requirement only applies at this stage if the timing is being checked statically. If the timing is to be checked dynamically, it will have been set in such a position to start the engine, and the check can then be made with the engine running.

28. Fit the upper timing covers and the belt inspection plate.
29. Fit the external drive belts and adjust to the correct tension.

*If the engine is in the vehicle, carry out the following operations:*

30. Fit the radiator, re-connect all hoses and fan cables.
31. Fit the bonnet locking platform and radiator grille.
32. Fit the intake air duct.
33. Refill with coolant (50% anti-freeze) to the correct level.
34. Check the oil level and top up as necessary.
35. Re-connect the batteries, positive terminals first.
36. Start the engine and run until normal operating temperature is reached. Check the coolant level and top up as necessary.

**WARNING: PLACE A THICK CLOTH OVER THE CAP AND EXPANSION TANK BEFORE ATTEMPTING TO REMOVE THE CAP SLOWLY, TO AVOID THE POSSIBILITY OF SCALDING IF THE ENGINE IS HOT.**

37. Check / adjust the fuel injection pump timing dynamically (if not already checked statically).

## CYLINDER HEAD

### CAMSHAFT PULLEY AND OIL SEAL

#### Remove and Refit

**NOTE:** The camshaft front oil seal is directly behind the camshaft pulley and can be renewed after removing the pulley as follows.

#### Camshaft Pulley Remove

**Tools required:** 0480054 (18G 1205), LDV 104.

*The camshaft pulley and front oil seal can be removed / renewed in situ, but the following operations must be carried out first.*

1. Disconnect the battery(s), negative (earth) terminal(s) first.
2. Detach the intake air duct.
3. Remove the timing belt inspection plate and the two upper timing belt covers.

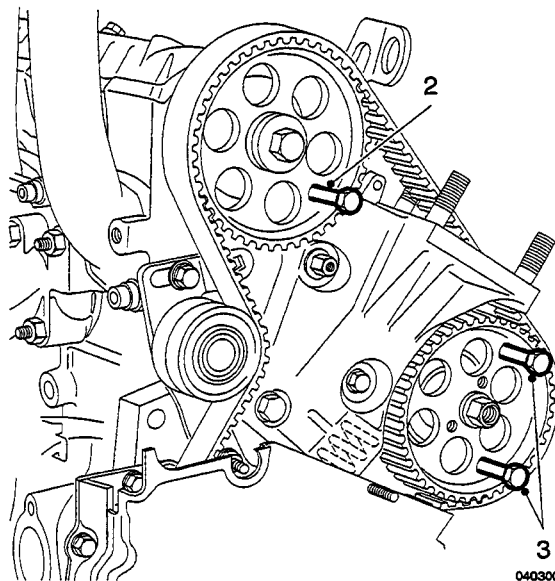
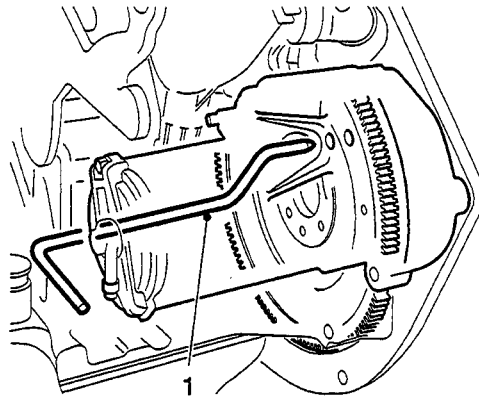

**Fig.1 Fitting timing pin and timing bolts**

1. Flywheel timing pin LDV 104
2. Camshaft timing bolt
3. Injection pump timing bolts
4. Turn the crankshaft clockwise until no.4 cylinder (front of engine) is at TDC firing position. Fit the timing pin LDV 104 in the flywheel location.  
Fit suitable length M8 bolts in the camshaft pulley and fuel injection pump pulley timing holes, finger-tight only.

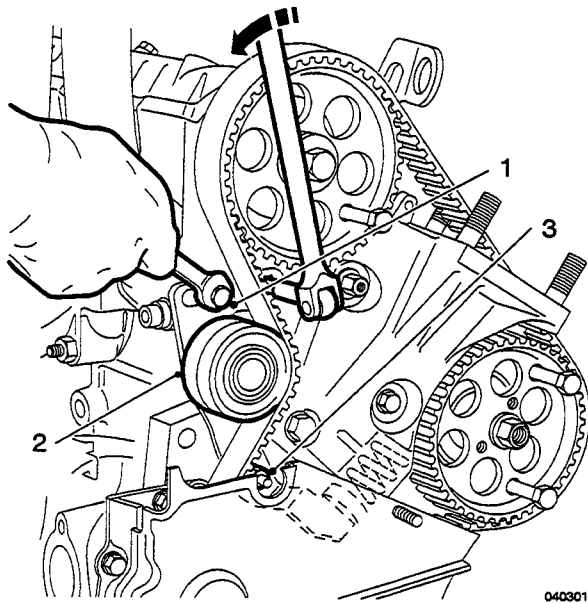

**Fig.2 Releasing timing belt tension**

1. Tensioner securing bolt
2. Tensioner roller
3. Tensioner securing nut

5. Slacken the timing belt tensioner securing nut and bolt.

Release the belt tension by pulling the tensioner roller fully away from the belt against spring pressure, and tighten the securing bolt.

**NOTE:** A square drive hole is provided in the tensioner bracket to facilitate this.

6. Carefully ease the timing belt off the camshaft pulley.
7. Remove the camshaft timing bolt.

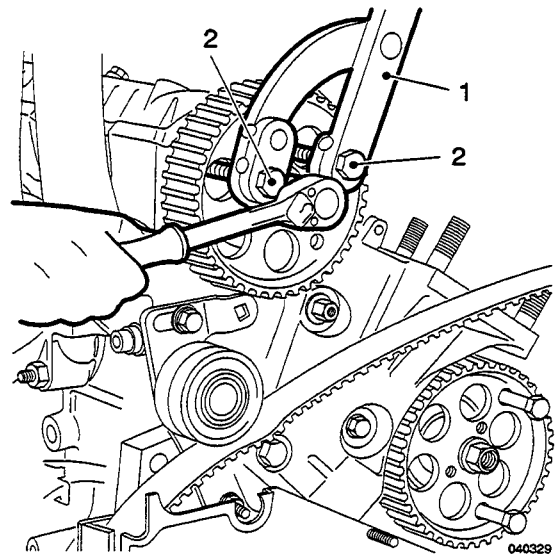

**Fig.3 Removing camshaft pulley**

1. 0480054 (18G 1205)
2. Bolts

8. **CAUTION: Do not allow the camshaft to turn.**

Restrain the camshaft pulley with flange holder 0480054 (18G 1205) fitted with suitable length bolts/nuts, and remove the pulley securing bolt.

9. Remove the camshaft pulley.

#### Camshaft Front Oil Seal

##### Remove and Refit

**Tools required:** 0480028 (18G 1508), 0480039 (FR 1509), 0480054 (18G 1205), 0480066, LDV 104.

Remove the camshaft pulley as described in the section 'Camshaft Pulley Remove', then proceed as follows.



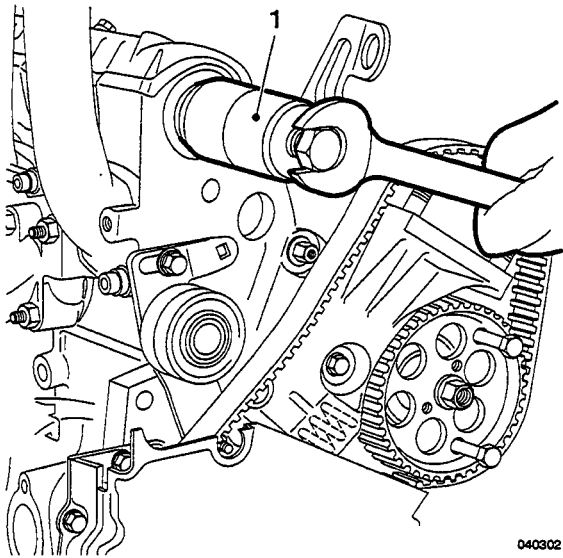

040302

**Fig.4 Removing camshaft oil seal**

1. 0480028 (18G 1508)

10. Remove the camshaft front oil seal using tool 0480028 (18G 1508).

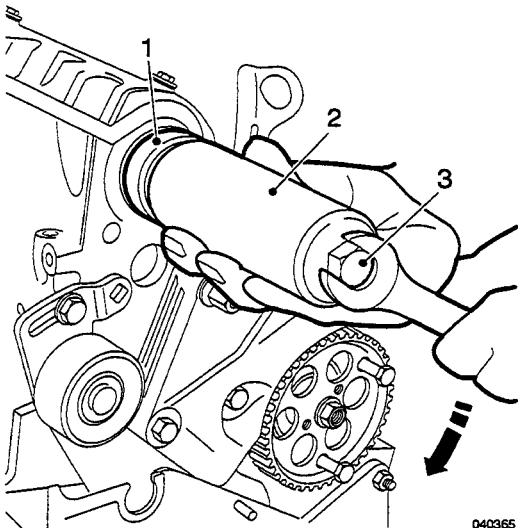

040365

**Fig.5 Fitting camshaft oil seal**

1. Oil seal
2. 0480039 (FR 1509)
3. Bolt

11. Ensure the front of the camshaft is clean and the seal journal is serviceable. Sparingly lubricate the tip of a new seal with engine oil and fit it, garter spring inwards, using tool 0480039 (FR1509).

**NOTE:** If the engine is in situ, space limitations require that the seal is pulled into place using a suitable length bolt as shown in the illustration.

Refit the camshaft pulley as described in the following section.

**Camshaft Pulley – Refit**

**Tools required:** 0480054 (18G 1205), 0480066, LDV 104.

12. Fit the camshaft pulley, restrain it with flange holder 0480054 (18G 1205) fitted with suitable length bolts/nuts, and tighten the pulley securing bolt to the correct torque.

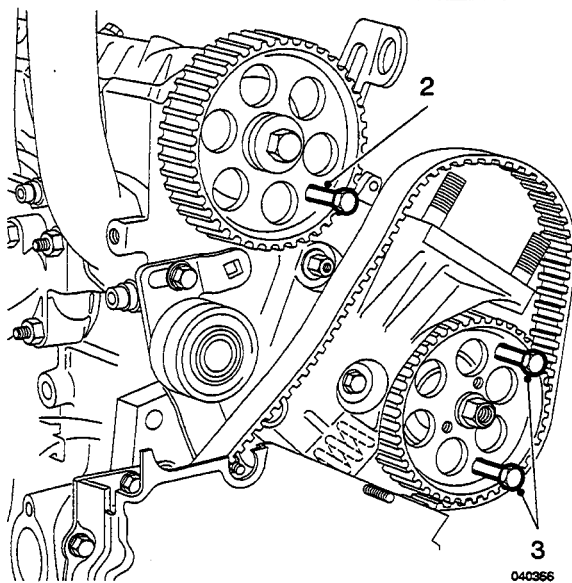
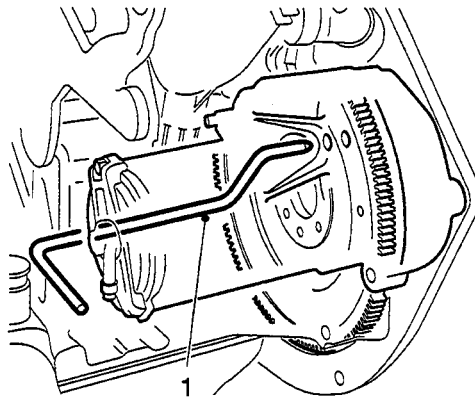

**Fig.6 Timing bolts and pin**

1. Flywheel timing pin LDV 104
2. Camshaft timing bolt
3. Injection pump timing bolt

13. Fit the camshaft pulley timing bolt, and check that the injection pump timing bolts and the flywheel timing pin LDV 104 remain in place.

**CYLINDER HEAD**

14. Carefully slide the timing belt over the pulleys, keeping the drive side taut.
15. Remove the camshaft and fuel injection pump timing bolts and the flywheel timing pin LDV 104.

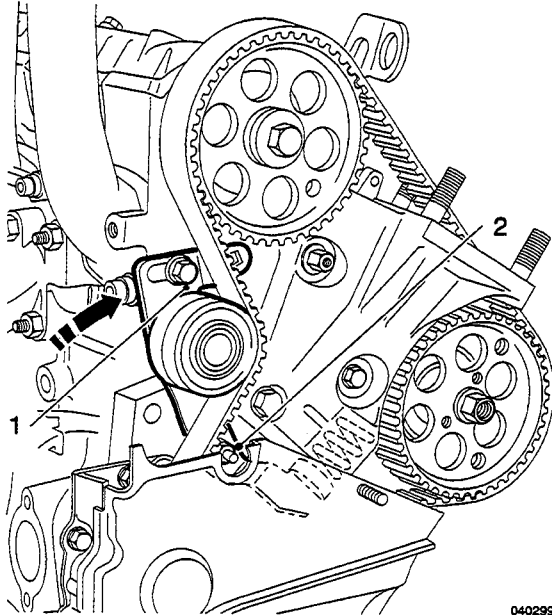

040299

20. Check the fuel injection pump timing as described in the section 'Fuel System'.  
**NOTE:** This requirement only applies at this stage if the timing is being checked statically. If the timing is to be checked dynamically, it will have been set in a position to enable the engine to be started, and the check can then be made with the engine running.
21. Fit the timing belt covers and the belt inspection plate.
22. *Connect the battery(s), positive terminal(s) first.*
23. *Check the fuel injection pump timing dynamically (if not already checked statically).*

**Fig.7 Adjusting timing belt tension**

1. Tensioner bolt
2. Tensioner nut

16. Slacken the tensioner securing bolt and nut by two turns, and allow the spring and plunger to self-tension the timing belt. Temporarily tighten the bolt and nut.
17. Turn the crankshaft clockwise 7 complete turns, then continue turning until the flywheel timing pin LDV 104 can be fitted, together with the camshaft and injection pump timing bolts.  
**NOTE:** If it is not possible to fit all the timing pins / bolts, the timing belt fitting procedure has not been carried out correctly and must be repeated.  
**NOTE:** Do not turn the crankshaft anti-clockwise.
18. Slacken the tensioner nut and bolt by two turns, and allow the spring and plunger to re-tension the timing belt. Then tighten the bolt and the nut to the correct torque.
19. Remove the camshaft and fuel injection pump timing bolts, and the flywheel timing pin LDV 104.

## TAPPET CLEARANCES

### Tappet Clearances – Check

**CAUTION:** Do not attempt to turn the camshaft if the head is fitted to the cylinder block but the timing belt is removed unless specifically instructed to do so.

The tappet clearances can be checked in situ after carrying out the following operations

1. Disconnect the battery, negative (earth) terminal first.
2. Disconnect the Mann valve from its vertical pipe.
3. Remove the air box.
4. Remove the 3 bolts securing the camshaft cover, noting the position of the fibre and plain washers under the bolt heads. Lift off the cover and recover the rubber seal.

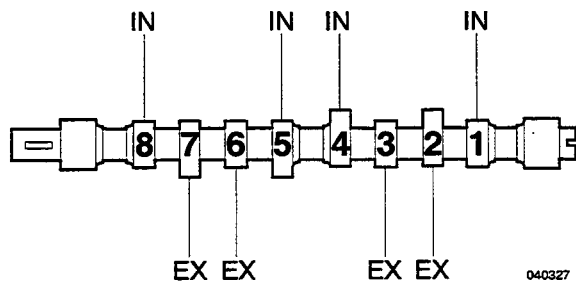

Fig.1 Camshaft

5. Turn the engine clockwise until no.7 and 8 valves are 'on the rock'.  
**NOTE:** No. 4 cylinder and nos. 7 & 8 valves are at the front of the engine.

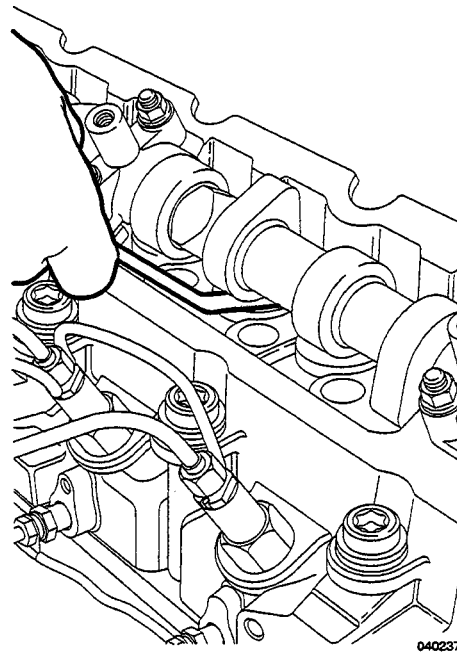

Fig.2 Checking tappet clearances

With no.7 & 8 valves 'on the rock', check and record the following clearances:

- No.1 tappet (rear of engine)
- No.2 tappet
- No.4 tappet
- No.6 tappet

Turn the engine until nos. 1 & 2 valves are 'on the rock'. Check and record the following clearances:

- No.3 tappet
- No.5 tappet
- No.7 tappet
- No.8 tappet

Tappet adjustment is only necessary if any of the clearances just measured are outside limits of:

Inlet	0,15 mm ± 0,04 mm (0.006 in. ± 0.0015 in.)
Exhaust	0,30 mm ± 0,04 mm (0.012 in. ± 0.0015 in.)

If adjustment IS necessary, see next section 'Tappet Clearances – Adjust'.

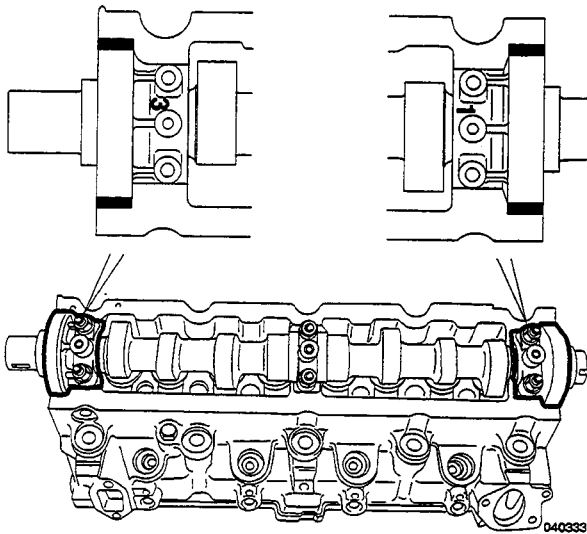

- Fit the camshaft cover and secure with:
  - fibre washers
  - plain washers
  - bolts. Tighten the bolts to the correct torque. Do NOT over-tighten.

**NOTE:** Make sure the coolant hose bracket is secured to the front cover bolt.

7. Fit the air box, tightening the bolts to the correct torque.
8. Connect the Mann valve.
9. Connect the battery(s), positive terminal(s) first.

**Fig.3 Sealing camshaft cover**

6. If adjustment is NOT necessary:

- Check that the camshaft cover gasket is serviceable.
- Sparingly apply Loctite 518 sealant at the 4 points on the cylinder head as illustrated.

**CYLINDER HEAD**

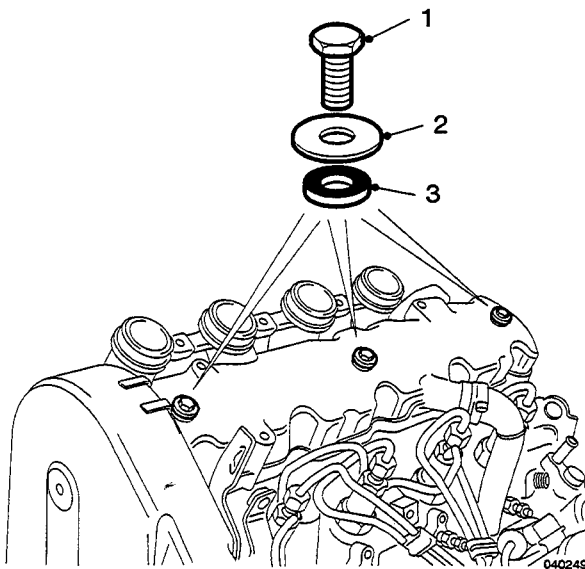

**Fig.4 Fitting camshaft cover**

1. Bolt
2. Plain washer
3. Fibre washer

### Tappet Clearances – Adjust

**Tools required:** LDV 104, 0480039 (FR 1509), 0480054 (18G 1205), 0480066.

**NOTE:** The following procedure assumes that the camshaft cover has been removed and the tappet clearance checking procedure (see Tappet Check, operations 1 to 5) has already been carried out. If adjustment is necessary, proceed as follows:

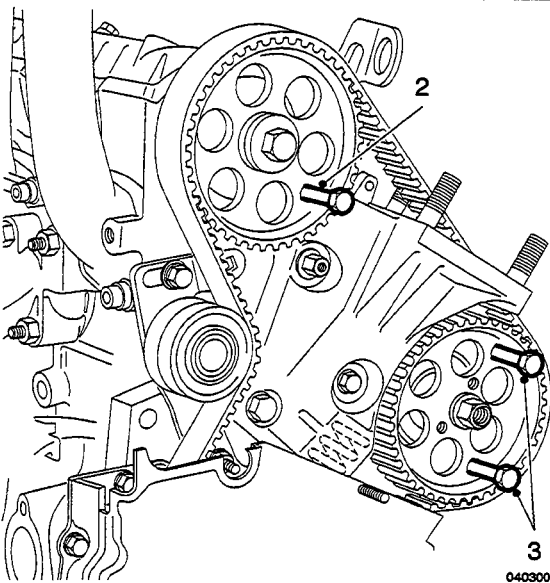
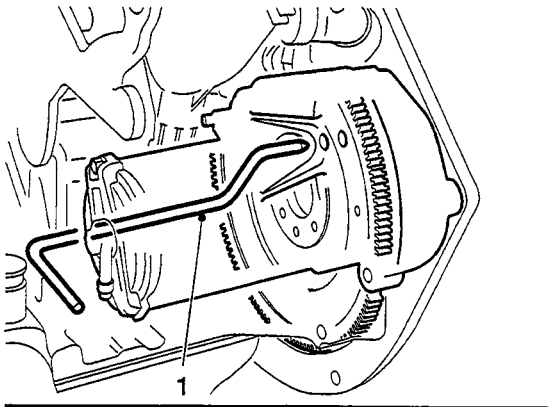

**Fig.5 Timing pin and timing bolts**

1. Flywheel timing pin LDV 104
2. Camshaft timing bolt
3. Injection pump timing bolts

1. Remove the timing belt upper covers, fit the timing pin / bolts, release the tension on the timing belt and remove the camshaft pulley as described in the section 'Camshaft Pulley Remove'.

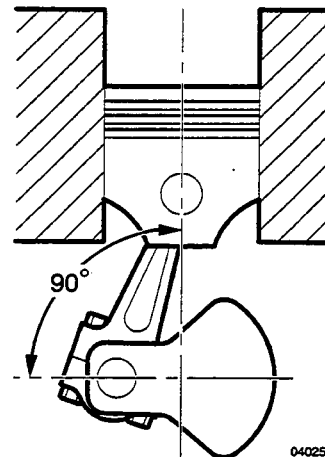

**Fig.6 Crankshaft in 'safe' position**

2. Remove the flywheel timing pin LDV 104, then turn the crankshaft anti-clockwise by 1/4 turn (90°) to the 'safe' position.

CYLINDER HEAD

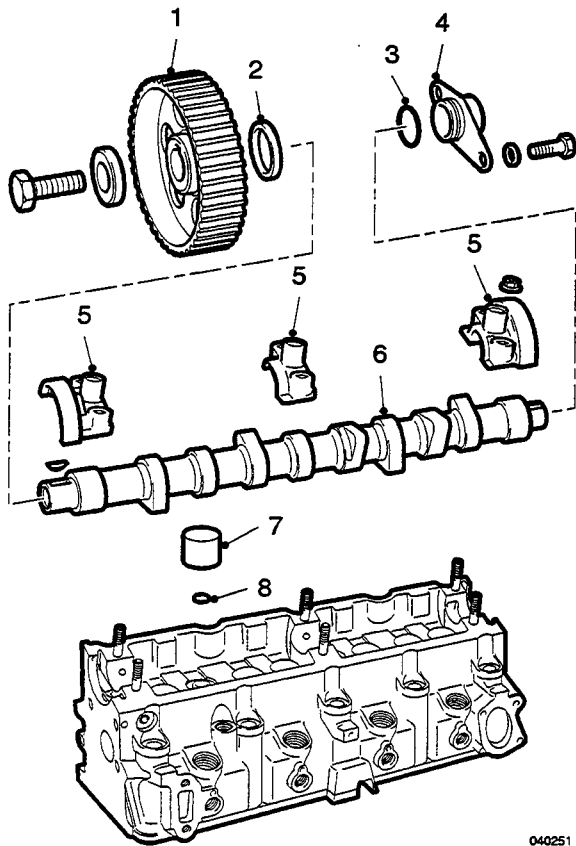

**Fig.7 Camshaft, tappet and shim layout**

1. Camshaft pulley
2. Oil seal
3. 'O' ring
4. Rear cover
5. Camshaft caps
6. Camshaft
7. Tappet
8. Shim

3. Remove the camshaft rear cover and discard the 'O' ring.
4. Note the identification markings on each camshaft bearing cap, then progressively release the 3 caps and remove the camshaft. Discard the oil seal.  
**NOTE:** The camshaft caps are line bored with the cylinder head during manufacture, and are not available separately.
5. **CAUTION: Do not allow the shims to fall down the oil drain passages in the cylinder head.**  
Carefully remove the tappets and shims that require adjustment, identifying them to their bore(s) for refitting. Use a micrometer to measure the thickness of each shim removed.

6. Calculate the correct shim thickness(s) required using the following formula:

$$A + B - C$$

- A = Measured tappet clearance  
 B = Thickness of shim removed  
 C = Correct tappet clearance

**Example:**

No.1 (inlet) valve, measured clearance 0,25 mm, thickness of shim removed 2,42 mm  
 Calculation:  $0,25 + 2,42 - 0,15 = 2,52$   
 Therefore shim required is 2,52 mm  $\pm$  0,04 mm.

7. Select the shim(s) required from the range available, then carefully locate it/them into its/their valve spring cap(s). Lubricate and fit each removed tappet.
8. Check that the crankshaft is still in the 'safe' 90° position.

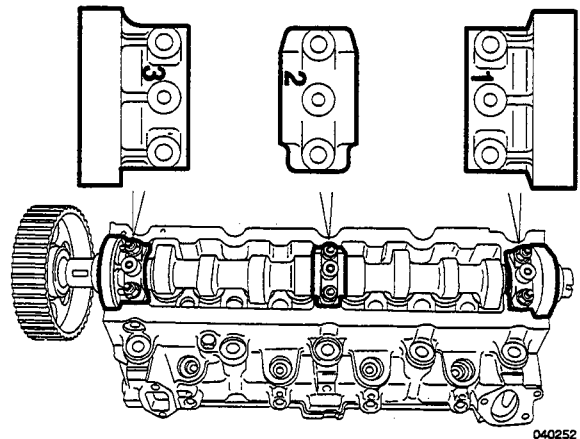

**Fig.8 Camshaft bearing cap marks**

9. Lubricate the camshaft and place in position, pulley end to the front. Temporarily fit the camshaft bearing caps, making sure they are in their correct locations. No.1 cap is fitted at the rear, and when the caps have been fitted the numbers should be readable from the front of the engine.  
Progressively tighten the cap securing nuts to the correct torque.
10. Before proceeding further, check all tappet clearances and re-adjust any that are outside tolerances.

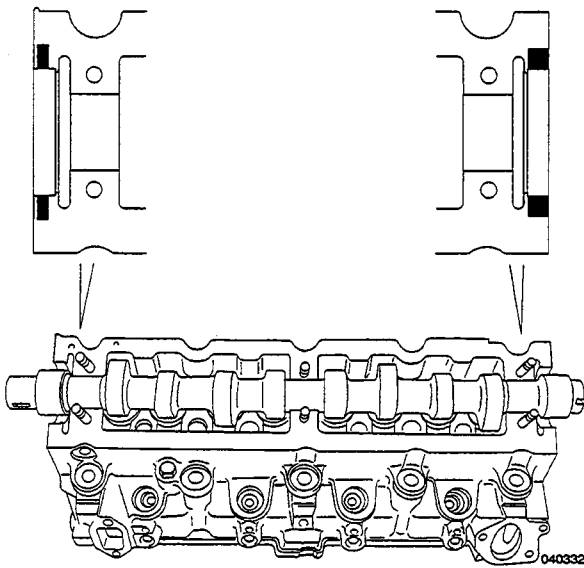

**Fig.9 Sealing camshaft bearing caps**

11. **CAUTION: Do not allow the seal to spread onto the journal areas, or into the grooves on the underside of caps 1 and 3.** Remove the camshaft bearing caps and sparingly apply Loctite 518 sealant at the points shown in the illustration.
12. Fit the caps in their correct locations as before and progressively tighten the securing nuts to the correct torque.
13. Fit a new 'O' ring to the rear cover, then fit the cover.

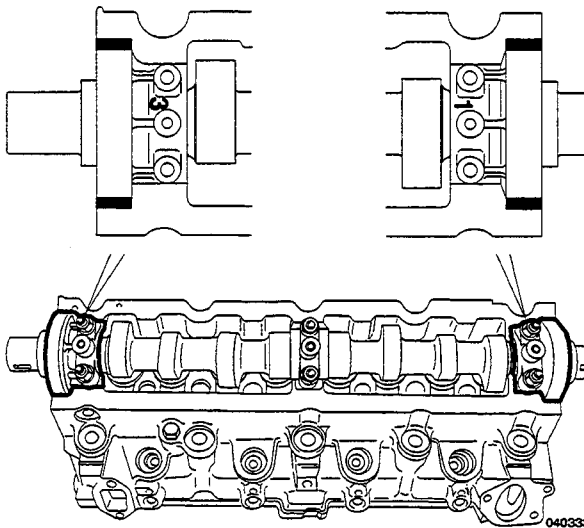

**Fig.10 Sealing camshaft cover**

14. Check that the camshaft cover rubber seal is serviceable. Sparingly apply Loctite 518 sealant at the 4 points on the cylinder head as illustrated.

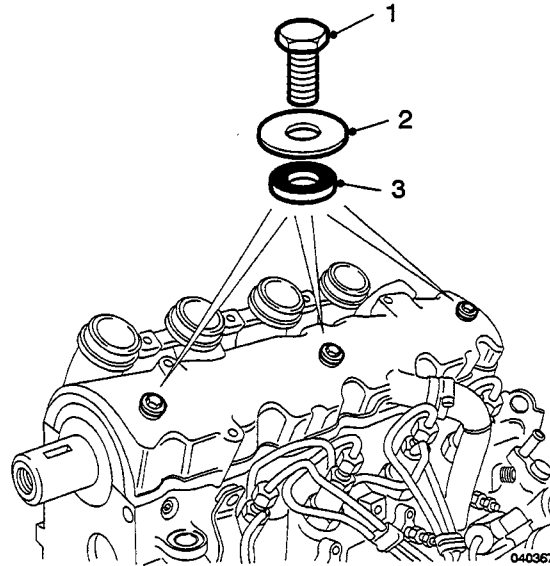

**Fig.11 Fitting camshaft cover**

1. Bolt
  2. Plain washer
  3. Fibre washer
15. Fit the camshaft cover and secure with:
    - fibre washers
    - plain washers
    - bolts. Tighten the bolts to the correct torque. Do NOT over-tighten.
- NOTE:** Make sure the coolant hose bracket is secured to the front cover bolt.

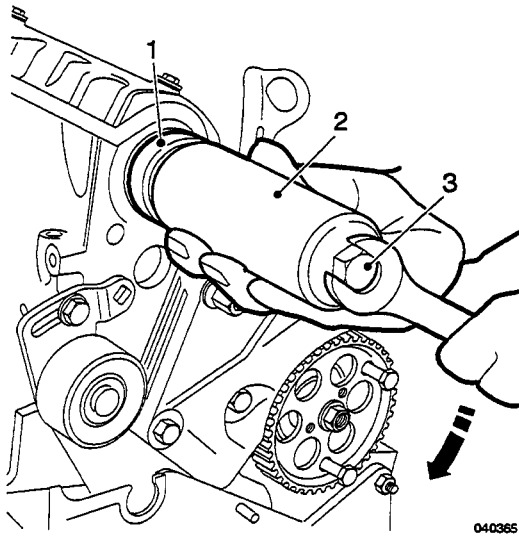

**Fig.12 Fitting camshaft oil seal**

1. Oil seal
2. 0480039 (FR 1509)
3. Bolt

16. Sparingly lubricate the lip of a new camshaft front oil seal and fit it, garter spring inwards, using tool 0480039 (FR 1509).  
**NOTE:** If working with the engine in situ, use a bolt and washer through the centre of the tool as illustrated to pull the seal into place.
17. Ensure the key is located correctly, fit the camshaft pulley, and tighten the securing bolt to the correct torque

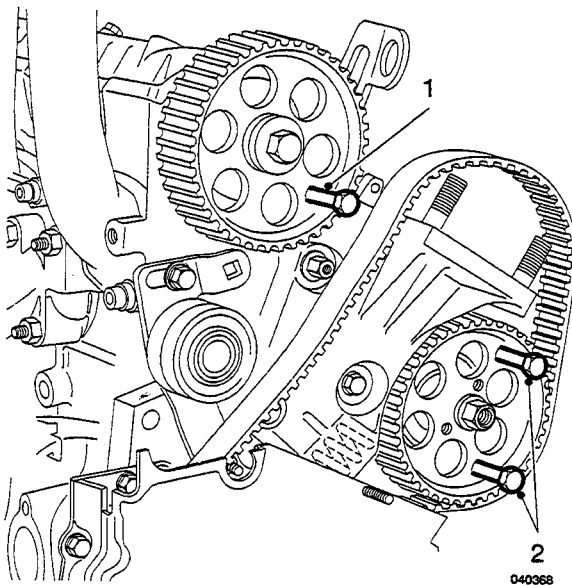

**Fig.13 Pulley timing bolts fitted**

1. Camshaft timing bolt
2. Injection pump timing bolts

18. Turn the camshaft clockwise until the timing bolt can be fitted through the pulley. Check that the two timing bolts are still fitted in the injection pump pulley.

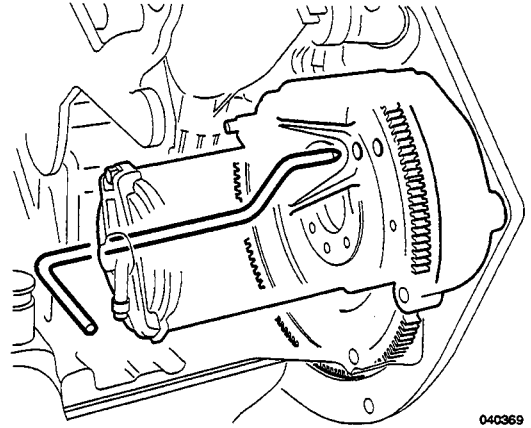

**Fig.14 Flywheel timing pin LDV 104**

19. Turn the crankshaft 90° **clockwise** until the timing pin LDV 104 can be fitted in the flywheel.
20. Carefully fit the timing belt while keeping its run taut on the drive side.
21. Remove the timing bolts and the timing pin LDV 104.



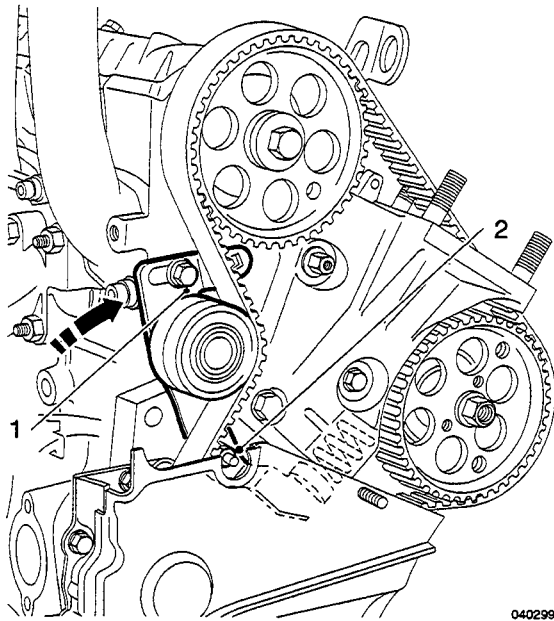

**Fig.15 Adjusting timing belt tension**

1. Tensioner bolt
  2. Tensioner nut
22. Slacken the tensioner securing bolt and nut by two turns, and allow the spring and plunger to self-tension the timing belt. Temporarily tighten the bolt and nut.
  23. Turn the crankshaft clockwise 7 complete turns, then continue turning until the flywheel timing pin LDV 104 can be fitted, together with the camshaft and injection pump timing bolts.
 

**NOTE:** If it is not possible to fit all the timing pins / bolts, the timing belt fitting procedure has not been carried out correctly and must be repeated.

**NOTE:** Do not turn the crankshaft anti-clockwise.
  24. Slacken the tensioner nut and bolt by two turns, and allow the spring and plunger to re-tension the timing belt. Then tighten the bolt and the nut to the correct torque.
  25. Remove the camshaft and fuel injection pump timing bolts and the flywheel timing pin LDV 104.
  26. Check the fuel injection pump timing as described in the section 'Fuel System'.
 

**NOTE:** This requirement only applies at this stage if the timing is being checked statically. If the timing is to be checked dynamically, it will have been set in a position to start the engine, and the check can then be made with the engine running.
  27. Fit the timing belt covers and the belt inspection plate.
  28. Fit the air box, tightening the bolts to the correct torque.
  29. Connect the Mann valve.
  30. Connect the battery(s), positive terminal(s) first.
  31. Check the fuel injection pump timing dynamically, (if not already checked statically.)

## CYLINDER HEAD

### Remove

**Tool required:** LDV 104.

The cylinder head can be removed with the engine in situ by first carrying out the following operations.

1. Disconnect the batteries, negative terminals first.
2. Disconnect the Mann valve from its vertical pipe, and remove the air box.
3. **WARNING: USE CAUTION IF THE COOLANT IS HOT.**  
Drain the coolant.
4. Disconnect the thermostat housing from the cylinder head and pull clear. Discard the gasket.
5. Disconnect:
  - Glow plug supply cable.
  - Throttle cable.
  - Exhaust down pipe.
  - Coolant bleed hose from cylinder head.
6. Remove the timing belt inspection plate and the two belt upper covers.

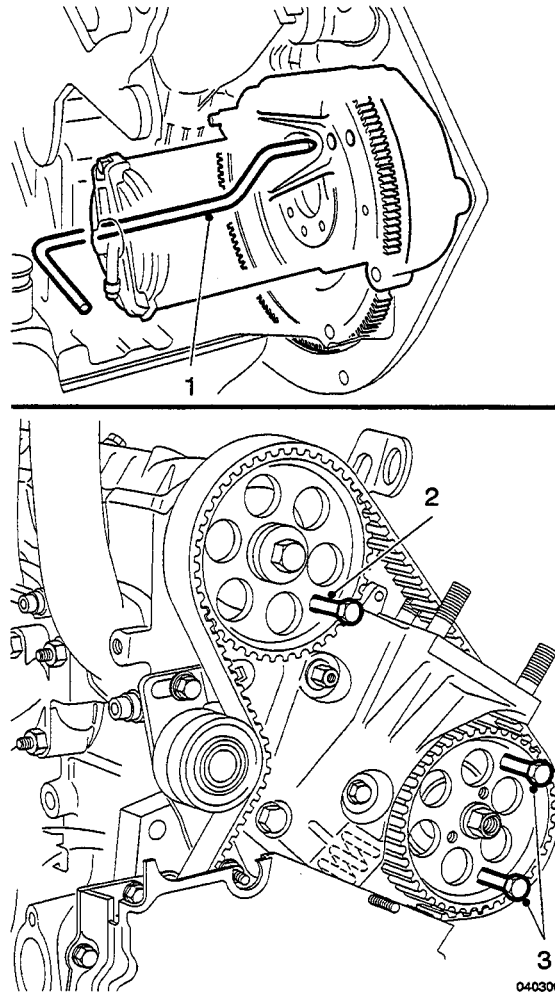

**Fig.1 Fitting timing pin and timing bolts**

1. Flywheel timing pin LDV 104
  2. Camshaft timing bolt
  3. Injection pump timing bolts
7. Turn the crankshaft clockwise until no.4 cylinder (front of engine) is at TDC firing position. Fit the flywheel timing pin LDV 104 in the flywheel location. Fit suitable length M8 bolts in the camshaft pulley and fuel injection pump pulley timing holes, finger-tight only.

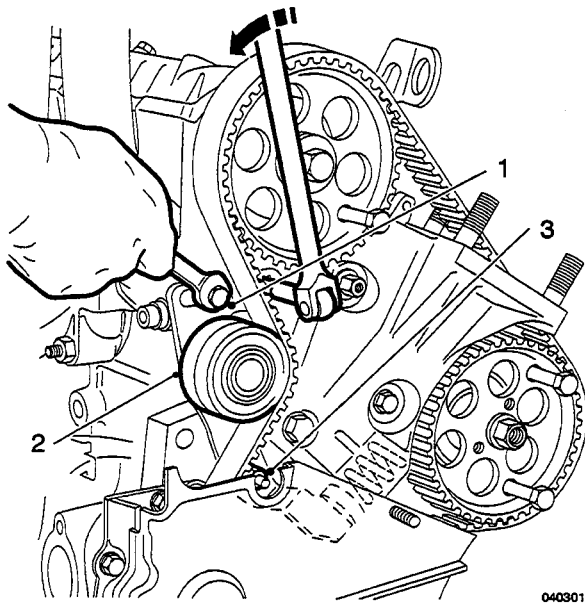

**Fig.2 Releasing timing belt tension**

1. Tensioner securing bolt
2. Tensioner roller
3. Tensioner securing nut

8. Slacken the timing belt tensioner securing nut and bolt.

Release the belt tension by pulling the tensioner roller fully away from the belt against spring pressure, and tighten the securing bolt.

**NOTE:** A square drive hole is provided in the tensioner bracket to facilitate this.

9. Carefully ease the timing belt off the camshaft pulley.

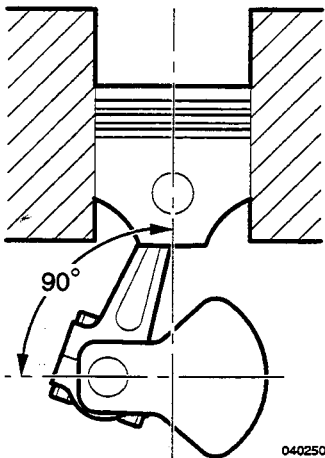

**Fig.3 Crankshaft in 'safe' position**

10. Remove the flywheel timing pin LDV 104, then turn the crankshaft **anti-clockwise** by 1/4 turn (90°) to the 'safe' position.
11. Remove the bolt which secures the belt tensioner plunger housing to the cylinder head.
12. Disconnect the breather pipe from the camshaft cover.

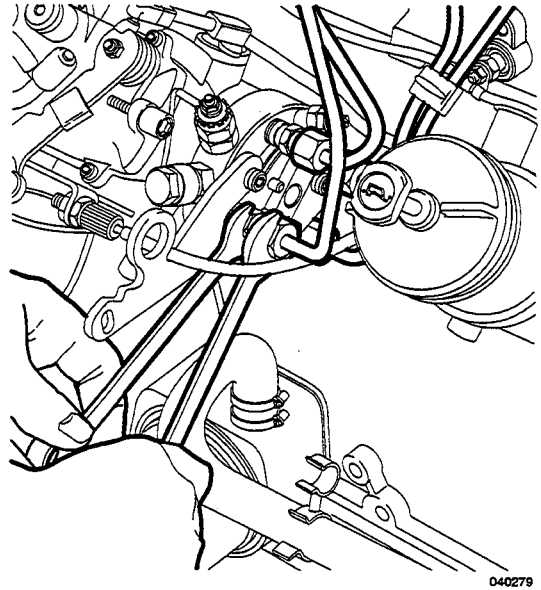

**Fig.4 Loosening fuel injector pipes**

13. Remove the fuel injector pipes, making sure each union is restrained from turning while its nut is loosened. Plug the unions.
14. Disconnect the spill return pipe.

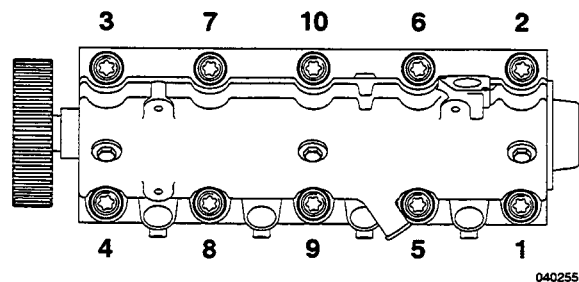
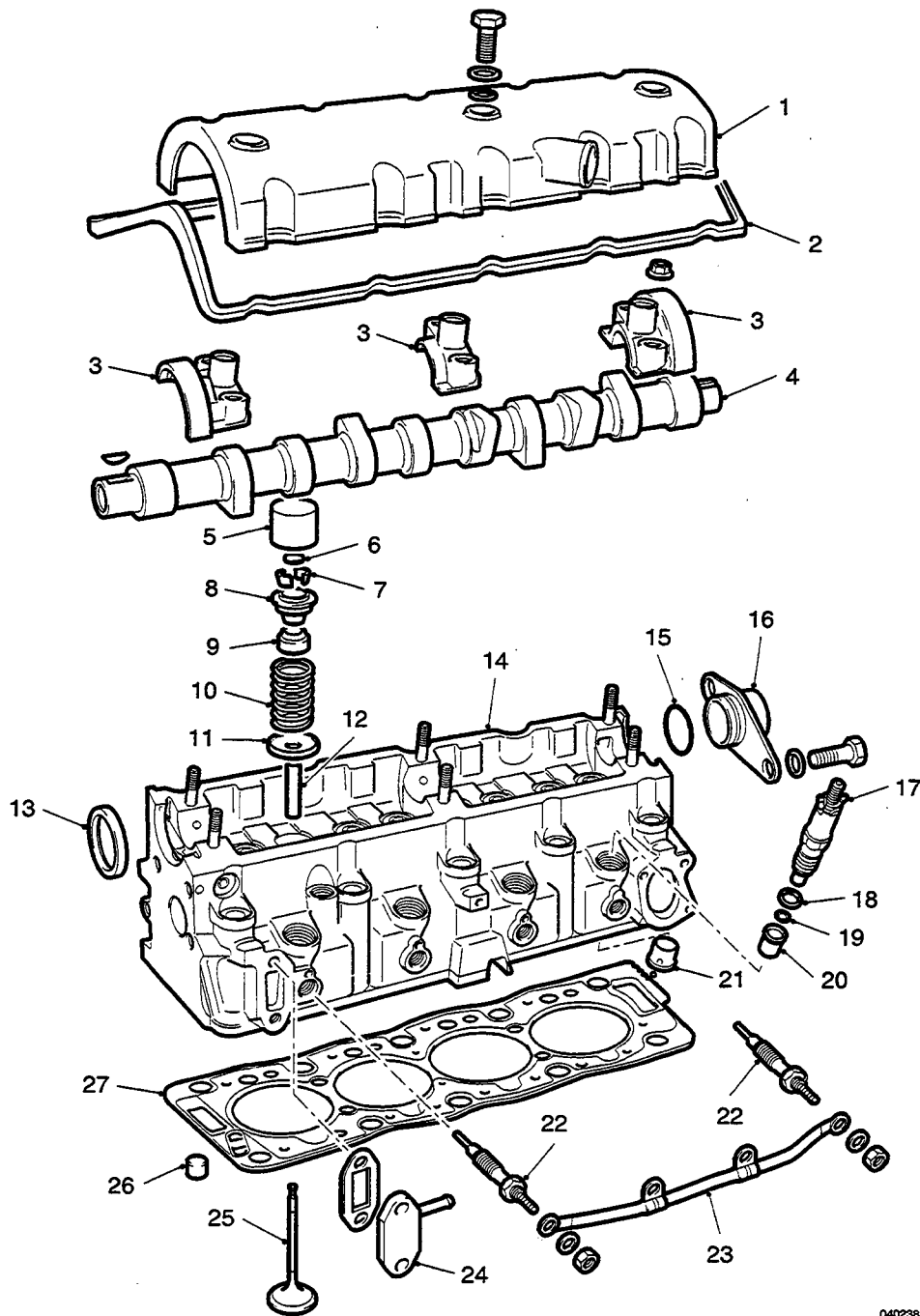

**Fig.5 Cylinder head bolt loosening sequence**

15. Remove the 10 cylinder head bolts in the sequence shown and carefully lift off the head.

**CAUTION:** Lay head on its side or on its face supported by wooden blocks to protect valves.

16. Remove and discard the cylinder head gasket. Clean off all traces of the gasket from the cylinder head and block faces.



CYLINDER HEAD

040238

**Fig.6 Cylinder head assembly**

- |                        |                         |                                |
|------------------------|-------------------------|--------------------------------|
| 1. Camshaft cover      | 10. Valve spring        | 19. Heat shield washer         |
| 2. Seal                | 11. Spring seat         | 20. Injector shroud            |
| 3. Camshaft caps       | 12. Valve guide         | 21. Swirl chamber              |
| 4. Camshaft            | 13. Camshaft oil seal   | 22. Heater plug                |
| 5. Tappet              | 14. Cylinder head       | 23. Heater plug cable          |
| 6. Shim                | 15. 'O' ring seal       | 24. Coolant bleed pipe adaptor |
| 7. Valve collets       | 16. Camshaft rear cover | 25. Valve                      |
| 8. Spring cap          | 17. Injector            | 26. Cylinder head dowel pin    |
| 9. Valve stem oil seal | 18. Copper washer       | 27. Cylinder head gasket.      |



## Dismantling

**Tools required:** 0480054 (18G1205), 0480059 (MS 1501), 1210507 (18G 1519A)

17. Remove the inlet and exhaust manifolds and discard the gaskets.
18. Remove the injectors using 0480059 (MS 1501), and remove the glow plugs.
19. Remove the camshaft pulley timing bolt. Restrain the camshaft pulley with flange holder 0480054 (18G1205) fitted with suitable length bolts / nuts, and remove the securing bolt to release the pulley.
20. Remove the camshaft rear cover and discard the 'O' ring.
21. Remove the camshaft cover, noting the position of the fibre and plain washers under the securing bolts.

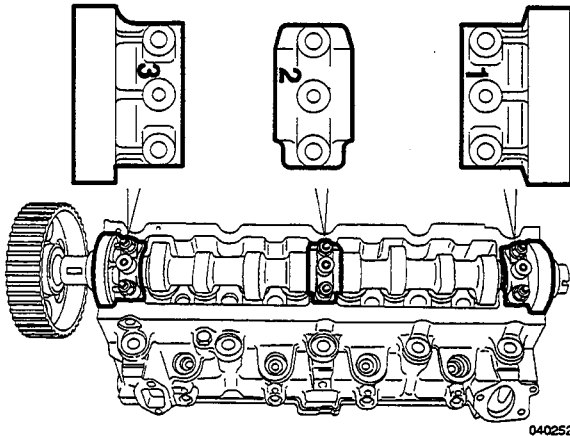

**Fig.7 Camshaft bearing marks**

22. Note the identification number on each camshaft bearing cap, then progressively release the 3 caps and remove the camshaft. Discard the oil seal.
23. Remove each tappet with its shim, and retain in their fitted order.

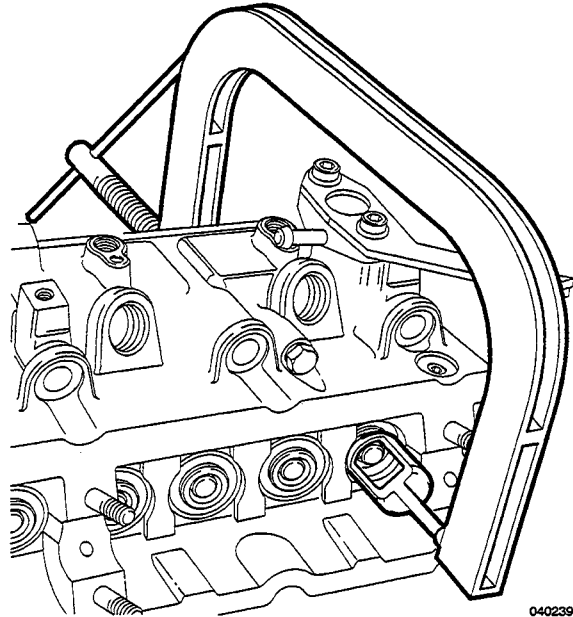

**Fig.8 Removing valves**

24. Use spring compressor 1210507 (18G 1519A) to remove the valves; retain the components in related sets. Discard the valve stem oil seals.



**Fig.9 Removing swirl chambers**

25. Identify each swirl chamber with its original location before using a suitable brass drift to tap it out (and the injector shrouds if necessary). Note that the swirl chambers are located by peened-in ball bearings.

### Inspection / Overhaul

- 26 Clean and inspect the cylinder head and component parts for wear and damage. Note particularly the valve seats, injector shroud locations, tappet bores and camshaft bearings. Inspect the supply oilways to the camshaft.

Check the camshaft cover sealing faces for damage.

**NOTE:** The camshaft journals are line bored and therefore the cylinder head and the camshaft bearing caps are only available as an assembly.

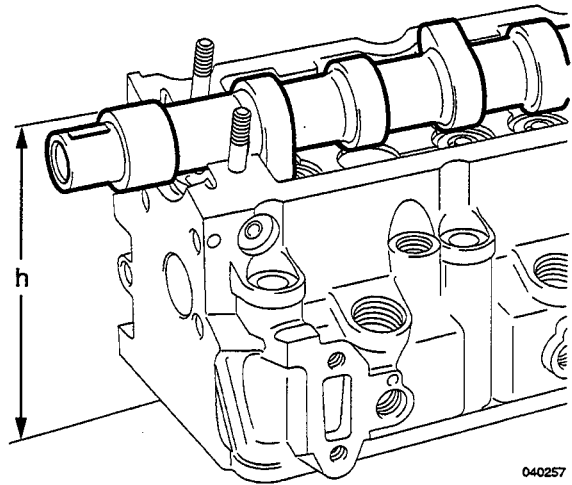

040257

**Fig.11 Cylinder head height**

If excessive distortion is evident, it is permissible to reface by machining up to 0.40 mm (0.016 in.) from the cylinder head, but only if the cylinder head height will remain within tolerance after machining.

To measure the height, refit the camshaft and secure with 2 bearing caps. Measure the distance 'h' from the head face to the top of the oil seal journal on the camshaft.

$$'h' = 157,40 \text{ to } 157,75 \text{ mm} \\ (6.197 \text{ to } 6.211 \text{ in.})$$

### CYLINDER HEAD DISTORTION

27. Before proceeding with other overhaul work the cylinder head must first be checked for distortion.

First lubricate and fit the camshaft, secure with the bearing caps and check that it turns freely. If it does not, the cylinder head must be renewed.

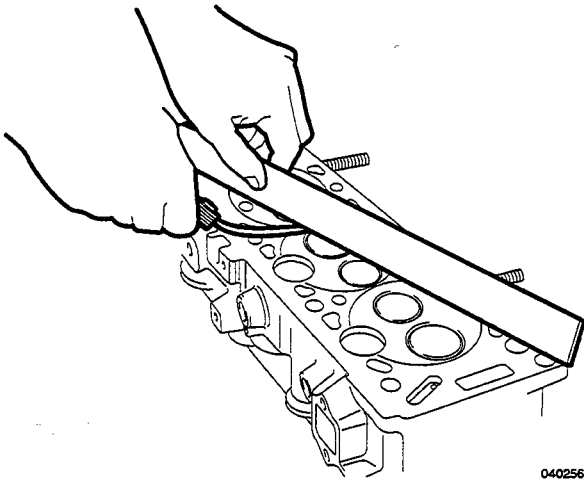

040256

**Fig.10 Checking for cylinder head distortion**

Use a straight edge and feeler gauge to check for distortion in a number of planes across the cylinder head face.

Maximum bow or twist 0,07 mm (0.003 in.)

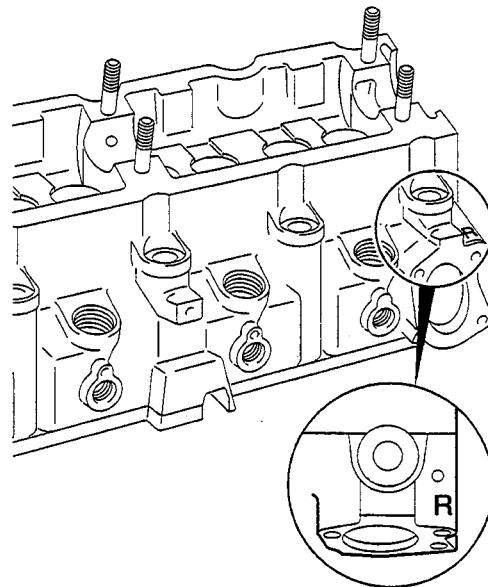

040258

**Fig.12 Machining identification**

After refacing, stamp the letter 'R' on the flat surface just above the coolant outlet.

**NOTE:** After machining it will be necessary to:

- Recut the valve seats to restore the correct valve head recess.
- Check / adjust swirl chamber protrusion.
- Fit compensation washers 0,40 mm (0.016 in.) thick under the valve spring seats.

### SWIRL CHAMBERS

28. Examine for cracks or damage.

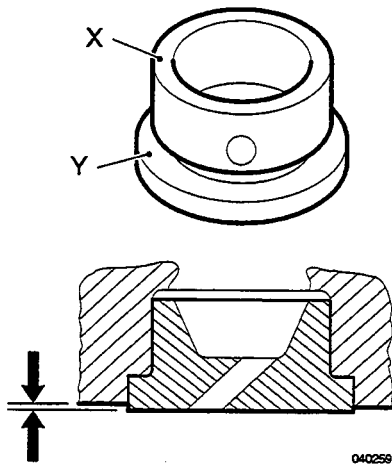

**Fig.13 Swirl chamber protrusion**

Check the protrusion of each swirl chamber above the face of the cylinder head.

**NOTE:** This will be incorrect if the head has been re-faced.

Swirl chamber protrusion:  
0 to 0,03 mm (0 to 0.001 in.)

If the protrusion is too great, it can be corrected by machining the swirl chamber at 'X' and 'Y'.

If there is no protrusion, two oversize swirl chambers are available and the head must be machined to accommodate them as follows.

Measure the outer diameter of the flange of the new swirl chamber, and machine the cylinder head to give an interference fit of 0,05 mm (0.002 in.).

Install the swirl chamber and measure the protrusion. If excessive, machine faces 'X' and 'Y' equally until the correct protrusion is obtained.

### VALVE SEATS

29. Examine the seats for damage and pitting.

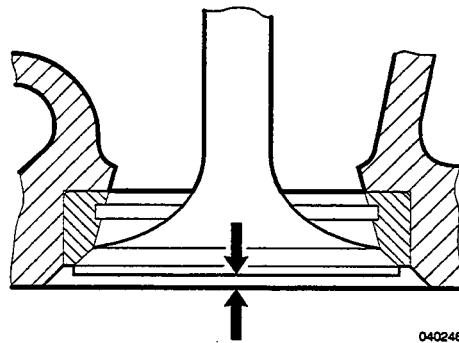

**Fig.14 Valve recession**

Fit each valve in turn and check its recession by measuring the depth of the valve below the face of the cylinder head.

Inlet 0,5 – 1,05 mm (0.002 – 0.04 in.)  
Exhaust 0,9 – 1,45 mm (0.035 – 0.06 in.)

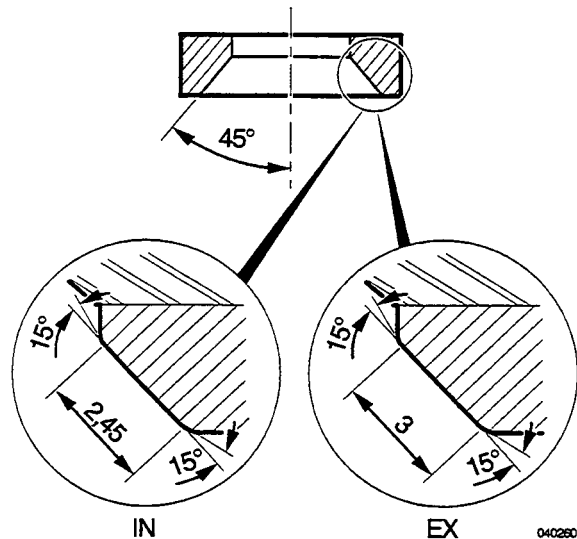

**Fig.15 Valve seats**

IN – Inlet  
EX – Exhaust

Seats can be re-cut to the dimensions shown.

After re-cutting valve seats, the valve recession must be checked.

**NOTE:** To ensure concentricity of each seat to its valve guide, they should not be re-cut until the guides have been checked and renewed as necessary (see VALVE GUIDES).

One oversize seat is available for both inlets and exhausts, and can be fitted as follows.

**WARNING: WEAR EYE PROTECTION.**

A faulty valve seat can be renewed in the normal manner by machining a crescent in the seat, and then split it for removal. Accurately measure the diameter of the new seat, and machine the location in the cylinder head to give an interference fit of:  
 Inlet 0,161 mm (0.0063 in.)  
 Exhaust 0,037 mm (0.0054 in.)

The new seat must be chilled (typically using liquid Nitrogen) prior to installation.

**VALVE GUIDES**

30. Check each valve guide for wear or damage.

If renewal is necessary, two oversize guides are available.

Fit the new guide as follows:

- Press out the old guide towards the camshaft side using a suitable mandrel.
- Ream the cylinder head to the dimension given in 'Data' to suit the dimension of oversize guide selected.

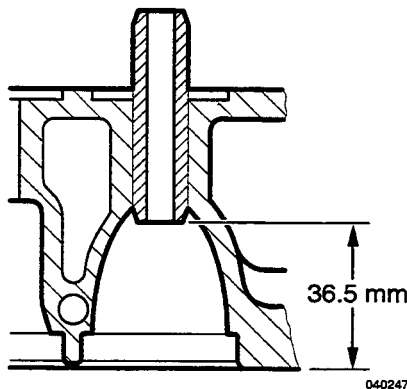

**Fig.16 Fitted position of valve guide**

- Press in the oversize guide until it is 36 to 37 mm (1.42 to 1.46 in.) from the cylinder head face.
- Ream out the fitted guide to 8,02 to 8,22 mm (0.3157 to 0.3236 in.).

**NOTE:** After fitting a new guide, the concentricity of its valve seat must be checked and refaced as necessary (see VALVE SEATS).

**VALVES**

31. Check the valve heads for cracks, pits and signs of burning. Check the stems for wear and correct fit in their guides. Check the valves for concentricity.

Minor imperfections on inlet valves may be rectified by re-cutting the valve head face. Exhaust valves cannot be re-faced.

**NOTE:** After rectification, the valve recession in the head must be checked and the valve renewed if outside tolerances.

Lap each valve into its seat using a fine paste until a satisfactory seal is obtained.

Thoroughly clean each valve, place in position and check its recession.

**VALVE SPRINGS, CAPS, SEATS, COLLETS & TAPPETS**

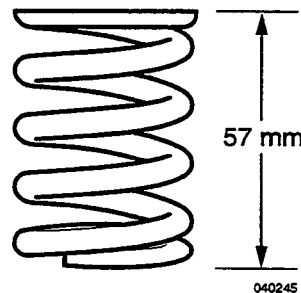

**Fig.17 Valve spring length**

32. Inspect the springs for damage. Check their free length which should be 57 mm (2.24 in.) and the length under load. ( See "Data").

Inspect the spring caps, seats and collets for obvious signs of wear or damage.

Inspect the tappets for pitting or wear on the camshaft contact face. Examine the outside diameter for wear or scoring. If scored, check the relevant bore in the head.

Replace components as necessary.

**CAMSHAFT & CAMSHAFT COVER**

33. Inspect all lobes, and bearing and oil seal journals for wear and damage. Camshaft end-float is controlled by the centre bearing cap and is not adjustable.

Camshaft end-float: –  
 0,025 to 0,114 mm (0.001 to 0.0045 in.)

Inspect the camshaft cover gasket.

**INJECTOR SHROUDS**

34. Inspect the injector shrouds for cracking or pitting. Renew as necessary.

To refit each shroud, locate it in the head, position an old copper washer on its outer diameter and tap it into the head using a suitable drift against the copper washer. Final positioning of the shroud can be left until it is pushed into place when fitting the injector.





## Re-assembly

**Tools required:** 0480039 (FR 1509), 1210507 (18G 1519A).

Before starting re-assembly, check that all swarf, grinding paste etc. has been removed from the cylinder head, valves etc.

Place the head on suitable supports.

35. Working at each valve in turn, fit:

- A new valve oil seal.
- The valve, the stem lubricated with engine oil.
- Valve spring seat (with 0,40 mm compensation washer under seat if head has been re-faced).
- Valve spring, either way up.
- Valve spring cap.

Compress the spring with 1210507 (18G 1519A) and fit the collets.

36. **CAUTION: Do not drop shims down the oil drain passages in the head.** Lubricate and fit the original shims and their tappets.

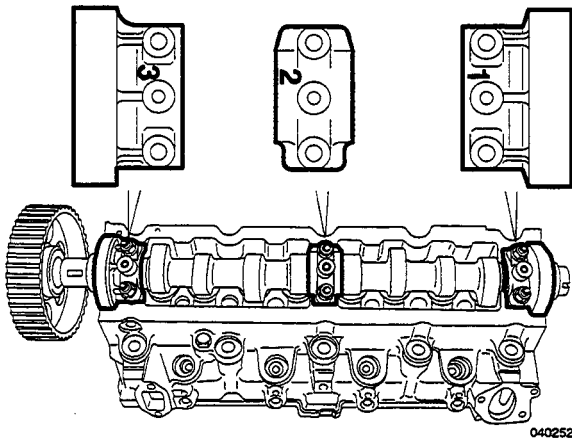

**Fig.18 Camshaft bearing cap marks**

37. Fit the camshaft temporarily, pulley end to the front, to enable the tappet clearances to be checked.

Before fitting the camshaft bearing caps note the identification numbers on them, no.1 cap is fitted at the rear, and when the caps have been fitted the numbers should be readable from the front of the engine.

Fit the caps and progressively tighten the securing nuts to the correct torque.

38. Fit the camshaft pulley temporarily.

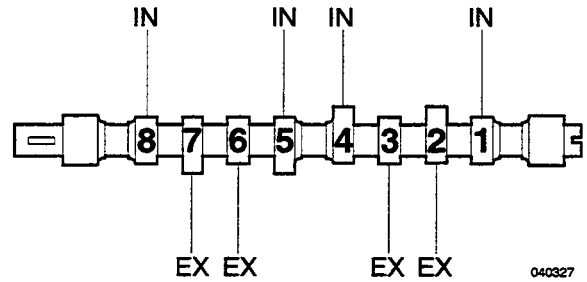

**Fig.19 Camshaft**

39. Turn the camshaft until no.7 and 8 valves are 'on the rock'.

**NOTE:** No. 4 cylinder and nos. 7 & 8 valves are at the front of the engine.

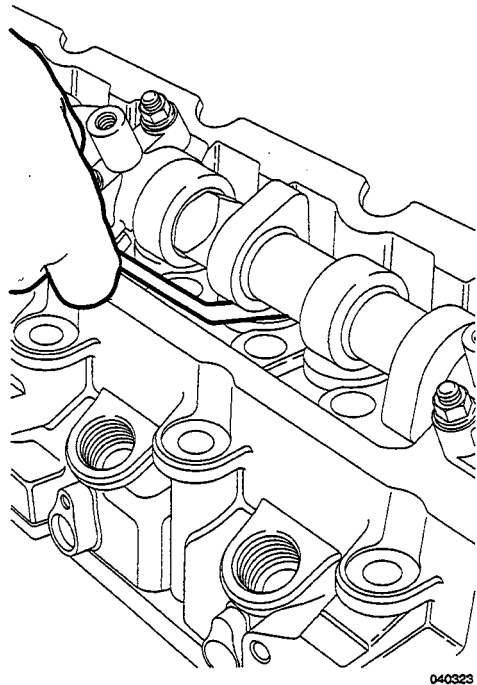

**Fig.20 Checking tappet clearances**

With no.7 & 8 valves 'on the rock', check and record the following clearances:

- No.1 tappet
- No.2 tappet
- No.4 tappet
- No.6 tappet

Turn the engine until nos. 1 & 2 valves are 'on the rock'. Check and record the following clearances:

- No.3 tappet
- No.5 tappet
- No.7 tappet
- No.8 tappet

Tappet adjustment is only necessary if any of the clearances just measured are outside limits of:

Inlet 0,15 mm ± 0,04 mm  
(0.006 in. ± 0.0015 in.)  
Exhaust 0,30 mm ± 0,04 mm  
(0.012 in. ± 0.0015 in.)

40. To adjust the clearances, remove the camshaft pulley and the camshaft.
41. Working at each tappet in turn that requires adjustment:
  - Remove the tappet and shim, and use a micrometer to measure the shim thickness.
  - Calculate the correct shim thickness(s) required using the following formula:  

$$A + B - C$$

A = Measured tappet clearance.  
 B = Thickness of shim removed.  
 C = Correct tappet clearance.

**Example:**  
 No.1 (inlet) valve, measured clearance 0,25 mm, thickness of shim removed 2,42 mm.

Calculation:  $0,25 + 2,42 - 0,15 = 2,52$

Therefore shim required is 2,52 mm ± 0,04 mm.
  - Select the shim required from the range available, then carefully locate it into its valve spring cap.
  - Lubricate and fit the tappet.
42. Lubricate the camshaft and place in position, pulley end to the front. Temporarily fit the camshaft bearing caps, making sure they are in their correct locations, and the correct way round as before. Progressively tighten the cap securing nuts to the correct torque.
43. Before proceeding further, check all tappet clearances and re-adjust any that are outside tolerances.

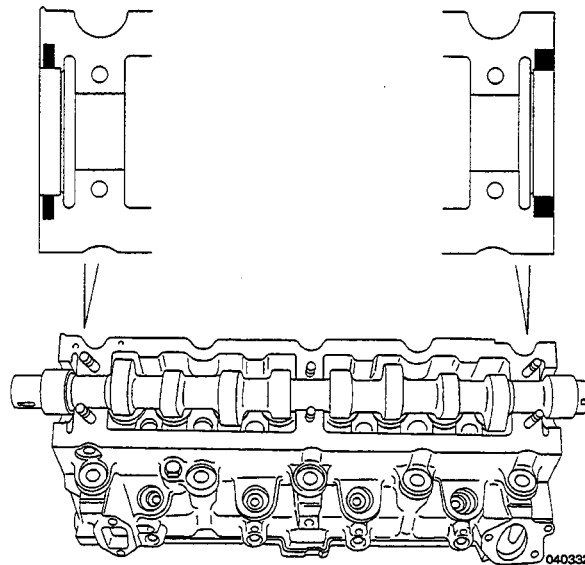
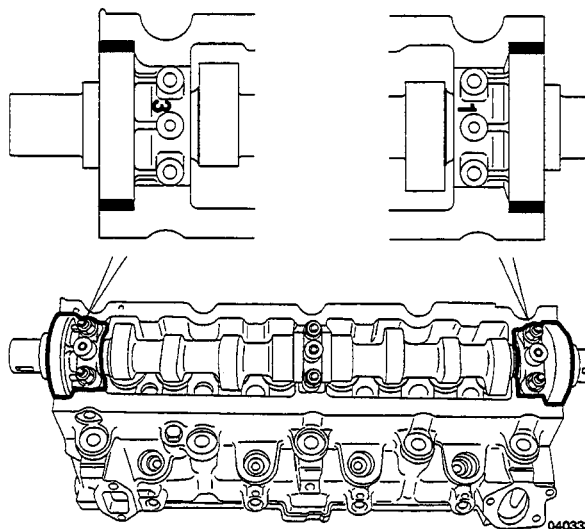

**Fig.21 Sealing camshaft bearing caps**

44. **CAUTION: Do not allow the seal to spread onto the journal areas, or into the grooves on the underside of caps 1 and 3.**

Remove the camshaft bearing caps and sparingly apply Loctite 518 sealant at the points shown in the illustration.

45. Fit the caps in their correct positions as before, and progressively tighten the securing bolts to the correct torque.



**Fig.22 Sealing camshaft cover**

46. Check that the camshaft cover seal is serviceable.  
Sparingly apply Loctite 518 sealant at the 4 points on the cylinder head as illustrated.

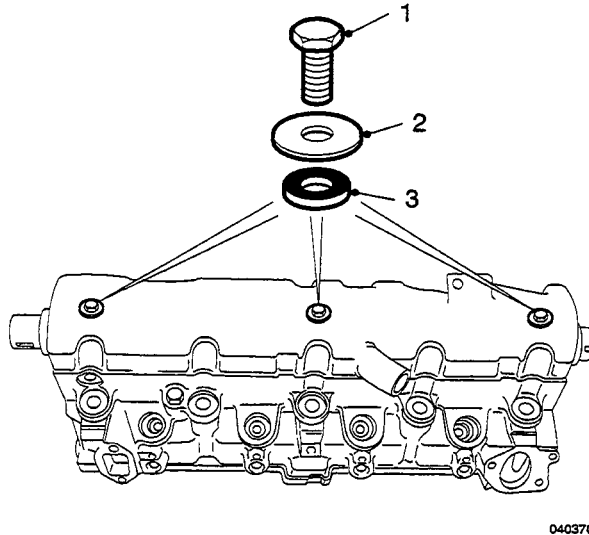

**Fig.23 Fitting camshaft cover**

1. Bolt
2. Plain washer
3. Fibre washer

47. Fit the camshaft cover and secure with:

- fibre washers
- plain washers
- bolts. Tighten the bolts to the correct torque. Do NOT over-tighten.

**NOTE:** Make sure the coolant hose bracket is secured to the front cover bolt.

48. Fit a new 'O' ring to the rear cover, then fit the cover.

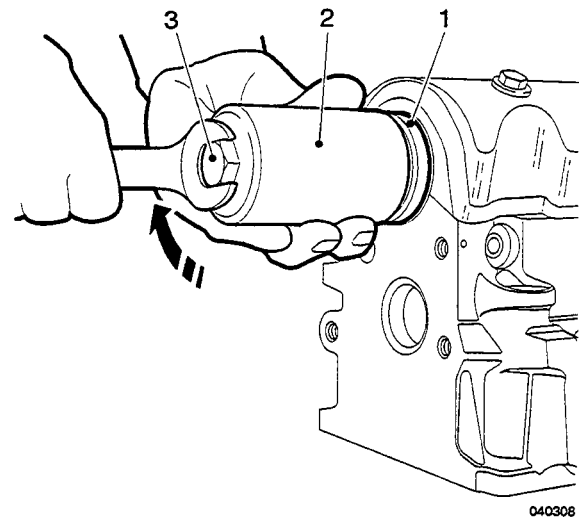

**Fig.24 Fitting camshaft oil seal**

1. Oil seal
2. 0480039 (FR 1509)
3. Bolt

49. Sparingly lubricate the lip of a new camshaft oil seal and fit it using tool 0480039 (FR 1509), garter spring inwards.
50. Ensure the key is correctly located and fit the camshaft pulley. Restrain the pulley with flange holder 0480054 (18G 1205) fitted with suitable length bolts/nuts, and tighten the securing bolt to the correct torque. Turn the camshaft until the timing bolt can be fitted through the pulley.
51. Fit the glow plugs, and tighten them to the correct torque.
52. Fit the manifolds, using new exhaust manifold gaskets.

#### Refit

**Tools required:** 0480059 (MS 1501), 0480066, 0480080 (LST 122), LDV 104.

53. Before the cylinder head can be fitted to the block, the correct cylinder head gasket must be selected by measuring piston protrusion as follows:

- Clean all traces of carbon from a small flat area in the centre of each piston above the gudgeon pin.

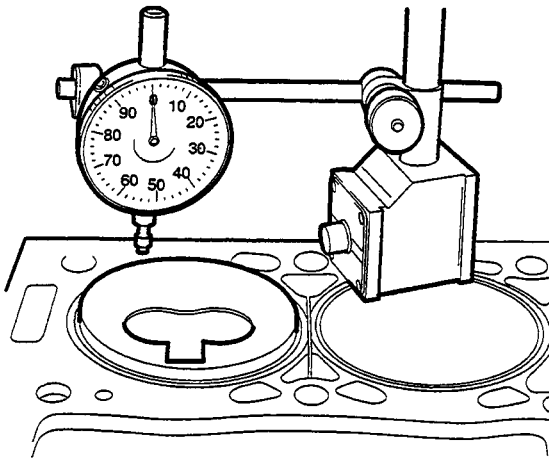

040309

**Fig.25 Zeroing gauge**

- Position a dial gauge so that the gauge stylus rests on a flat part of the cylinder block adjacent to the piston to be checked.
- Pre-load and zero the gauge.

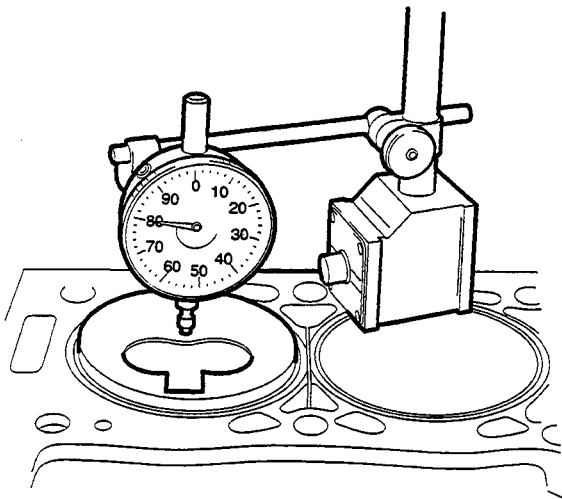

040262

**Fig.26 Measuring piston protrusion**

- Turn the crankshaft to position the piston at the top of its bore. Carefully move the gauge without disturbing its setting until its stylus rests on the previously cleaned area of the piston.

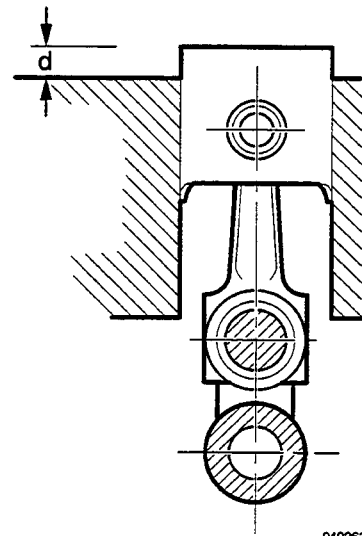

040263

**Fig.27 Piston protrusion**

- 'Rock' the crankshaft so that the gauge registers the rise and fall of the piston. Note the highest point reached by the piston.
- Record this figure, 'd', which is the protrusion of the piston being measured.
- Repeat the measuring procedure on the other three pistons.
- From the 4 measurements taken, identify the height of the piston which has the greatest protrusion. The measurement taken from that piston is used to select which cylinder head gasket is fitted.

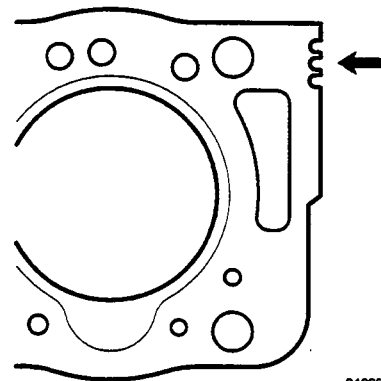

040264

**Fig.28 Cylinder head gasket identification**

- Two cylinder head gasket options are available, identifiable by the number of notches cut into the end of the gasket.
  - 2 notches – use for 0,77 mm (0.03 in.) protrusion (d) or less.
  - 3 notches – use for more than 0,77 mm (0.03 in.) protrusion (d).

CYLINDER HEAD

54. Turn the crankshaft anti-clockwise to position all the pistons at mid-stroke with the crankshaft pulley key at approximately 9 o'clock.
55. Clean the tapped holes in the cylinder block face (12 x 1,50 mm thread).
56. Check that the cylinder head centralising dowel is fitted (it may be useful to fit a dummy stud at the opposite end).
57. Fit the head gasket just selected, dry.
58. Position the cylinder head on the cylinder block.
59. Brush clean the threads of the cylinder head bolts, and coat the threads and the underside of the bolt heads with Molycote G Rapid. Fit new washers, concave face downwards (i.e. towards the cylinder head).

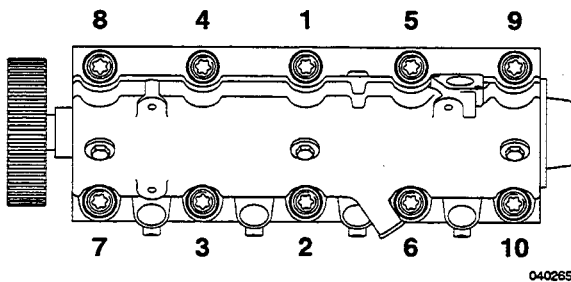

**Fig.29 Cylinder head bolt tightening sequence**

Tighten the cylinder head bolts using the following procedure:

- Pre-tighten all the bolts in the sequence shown to:  
**15 – 20 Nm (11 – 15 lbf ft).**
  - Tighten the bolts in the same order to  
**55 – 65 Nm (40 – 48 lbf ft).**
  - Tighten the bolts in the same order a further **180°**, using angular torque gauge 0480080 (LST 122).
60. Fit and tighten the two bolts securing the belt tensioner plunger housing to the cylinder head.
  61. Turn the camshaft until the timing bolt can be inserted in the pulley timing hole.

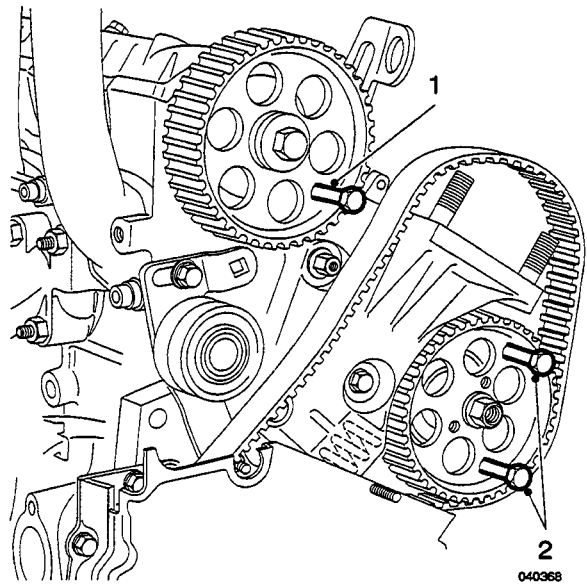

**Fig.30 Pulley timing bolts fitted**

1. Camshaft timing bolt
  2. Injection pump timing bolt
62. Check that the injection pump timing bolts are fitted.

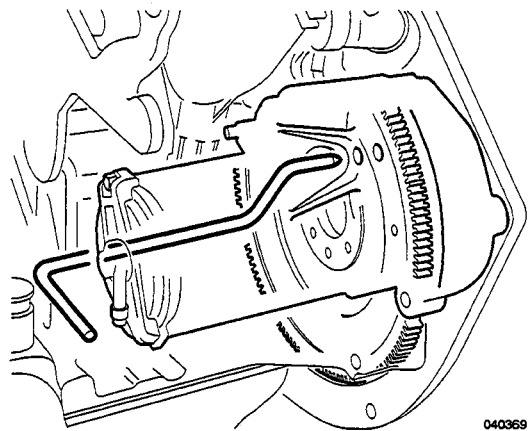

**Fig.31 Flywheel timing pin LDV 104**

63. Turn the crankshaft **90° clockwise** until the flywheel timing pin LDV 104 can be fitted in the flywheel.
64. Carefully fit the timing belt while keeping its run taut on the drive side.
65. Remove the timing bolts and the flywheel timing pin.

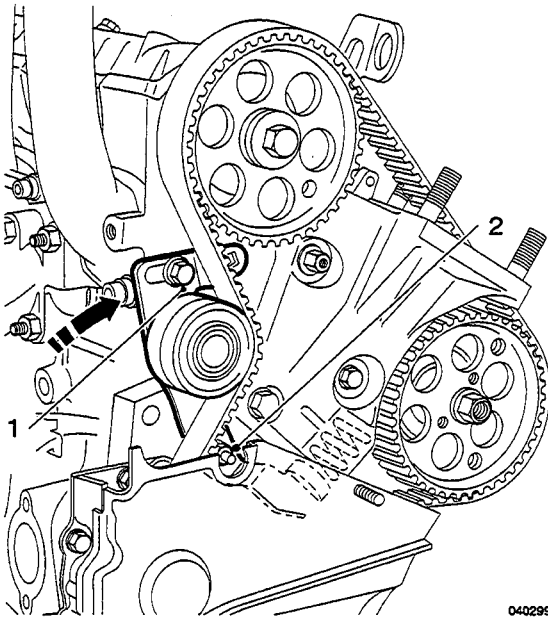

**Fig.32 Adjusting timing belt tension**

1. Tensioner bolt
  2. Tensioner nut
66. Slacken the tensioner securing bolt and nut by two turns, and allow the spring and plunger to self-tension the timing belt. Temporarily tighten the bolt and nut.
  67. Turn the crankshaft clockwise 7 complete turns, then continue turning until the flywheel timing pin LDV 104 can be fitted, together with the camshaft and injection pump timing bolts.
 

**NOTE:** If it is not possible to fit all the timing pins / bolts, the timing belt fitting procedure has not been carried out correctly and must be repeated.

**NOTE:** Do not turn the crankshaft anti-clockwise.
  68. Slacken the tensioner nut and bolt by two turns, and allow the spring and plunger to re-tension the timing belt. Then tighten the bolt and the nut to the correct torque.
  69. Remove the camshaft and fuel injection pump timing bolts and the timing pin LDV 104.
  70. Check the fuel injection pump timing as described in the section 'Fuel System'.
 

**NOTE:** This requirement only applies at this stage if the timing is being checked statically. If the timing is to be checked dynamically, it will have been set in a position to start the engine and the check can then be made with the engine running.

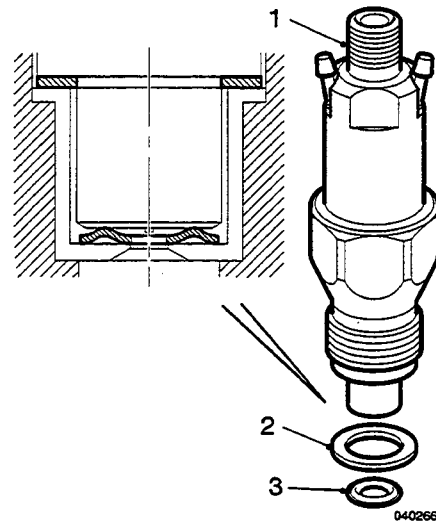

**Fig.33 Injector**

1. Injector
  2. Copper washer
  3. Heat shield washer
71. Fit new injector washers, heat shield washer domed side upwards, and fit the injectors using tool 0480059 (MS 1501), tightening them to the correct torque.

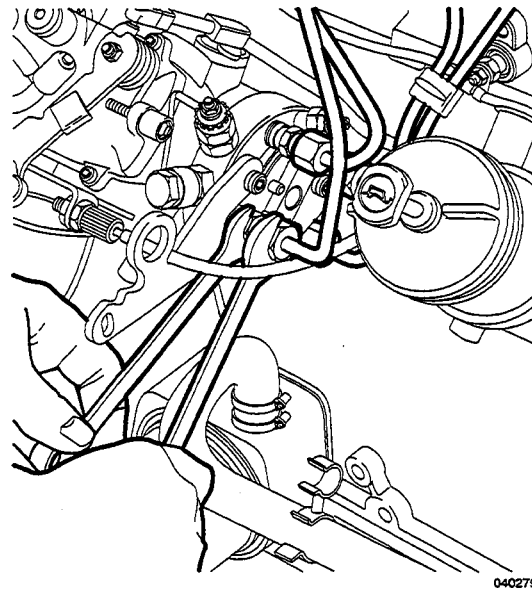

CYLINDER HEAD

**Fig.34 Tightening injector pipes**

72. Fit the fuel injector pipes, making sure each union is restrained while its nut is tightened.
73. Connect the spill return pipes to the injectors, and to the fuel injection pump.
74. Using a new gasket, fit the thermostat housing to the cylinder head.



75. Connect the breather pipe to the camshaft cover.
76. Fit the timing belt upper covers and the belt inspection plate.

*If the engine is in situ, complete the installation by carrying out the following operations:*

77. Connect:
  - Glow plug supply cable.
  - Throttle cable.
  - Exhaust down pipe.
  - coolant bleed hose to the cylinder head.
78. Fit the thermostat housing using a new gasket.
79. Fill with coolant (50% anti-freeze) to the correct level.
80. Check the oil level and top up as necessary.
81. Fit the air box and the air intake ducting. Connect the Mann valve.
82. Connect the battery(s), positive terminal(s) first.
83. Start the engine and run until normal operating temperature is reached. Check the coolant level and top up as necessary.  
**WARNING: PLACE A THICK CLOTH OVER THE CAP AND EXPANSION TANK BEFORE ATTEMPTING TO REMOVE THE CAP SLOWLY, TO AVOID THE POSSIBILITY OF SCALDING IF THE ENGINE IS HOT.**
84. Check / adjust the fuel injection pump timing dynamically (if not already checked statically).

## FLYWHEEL

### CLUTCH

#### Remove and Refit

Tools required: LDV 101, LDV 102.

#### Remove

- WARNING: THE GEARBOX MOUNTING PLATE IS HEAVY AND IS LOCATED TO THE CYLINDER BLOCK ON DOWEL PINS WHEN THE GEARBOX IS REMOVED. DO NOT ALLOW THE PLATE TO BE DISPLACED INADVERTENTLY.**  
Remove the gearbox, and temporarily secure the mounting plate with a suitable bolt.
- Fit the flywheel locking tool LDV 102.
- Support the clutch and progressively remove its securing bolts.  
Remove the pressure plate and friction plate.

#### Inspection

- Inspect the flywheel friction face and crankshaft spigot bush for wear or damage.  
**NOTE:** Flywheel bolts must be renewed if removed.  
Rectify as necessary.
- Check that the clutch release mechanism is serviceable.

#### Refit

- Fit the clutch friction plate and pressure plate, aligning the friction plate to the crankshaft spigot with the clutch centraliser LDV 101. Progressively tighten the securing bolts, finally tightening them all to the correct torque.
- Remove the flywheel locking tool LDV 102.
- Remove the mounting plate temporary securing bolt, and fit the gearbox.

## CRANKSHAFT REAR OIL SEAL & SPIGOT BUSH

#### Remove and refit

Tools required: 18G 1628A, LDV 101, LDV 102.

#### Remove

The crankshaft rear oil seal and spigot bush can be renewed with the engine in situ, after removing the gearbox.

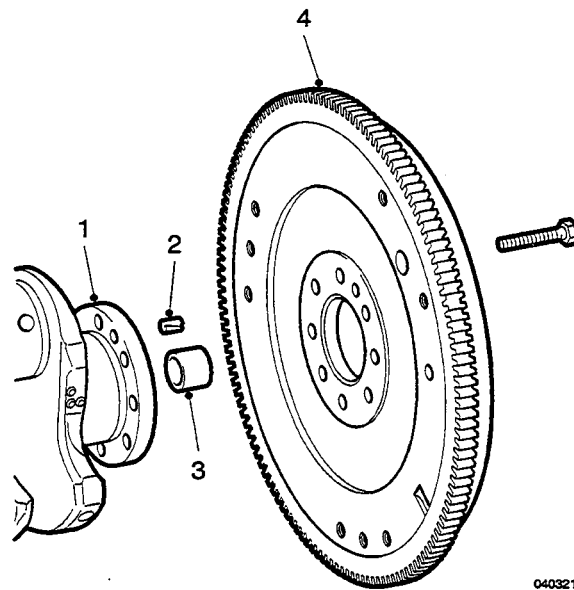

040321

Fig.1 Flywheel

- Crankshaft
  - Dowel
  - Spigot bush
  - Flywheel
- Remove the clutch as detailed in the section 'Clutch Remove and Refit', noting the warning given about the gearbox mounting plate.
  - Support the flywheel and remove and discard its securing bolts.  
Remove the flywheel restraining tool and the flywheel, noting the dowel pin.
  - To remove the spigot bush, fill the bush area with thick grease, and use a suitable size of drift to 'hydraulic' the bush out.



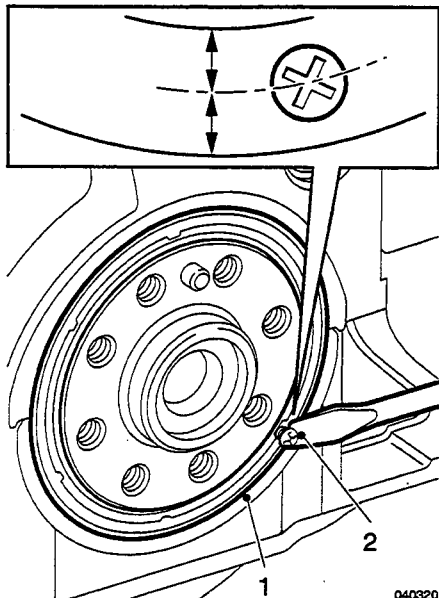
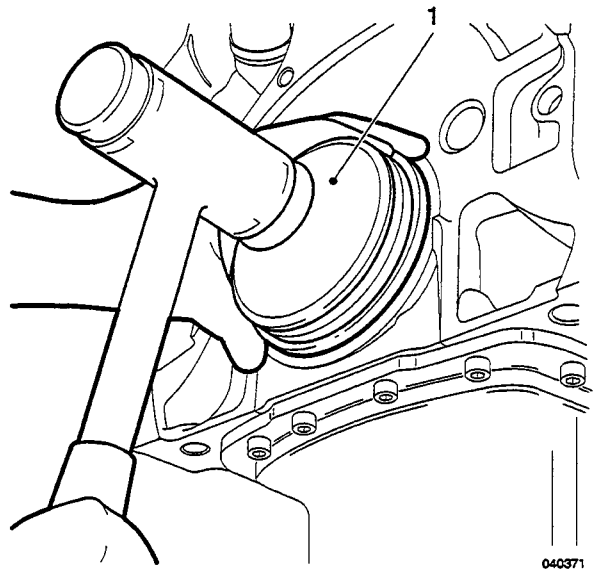

**Fig.2 Removing crankshaft rear oil seal**

1. Oil seal
  2. Self tapping screw.
4. To remove the crankshaft rear oil seal:
- **CAUTION: Do not allow the drill to penetrate too far and cause damage to the rear main bearing cap.** Carefully drill a 3 mm hole centrally across the section of the seal at the point illustrated.
  - Fit a suitable self-tapping screw and washer approximately 6 mm into the drilled hole.
  - Use the screw to prise out the seal as illustrated.
  - Clean out any swarf or dirt.

**Refit**

5. Carefully tap a new spigot bush into position. Check that the internal diameter of the bush has not become damaged.



**Fig.3 Fitting crankshaft rear oil seal**

1. Tool 18G 1628A
6. Fit the crankshaft rear oil seal as follows:
- Examine the smaller outside diameter surface of tool 18G 1628A to check that there are no imperfections that could damage the oil seal.
  - Smear the surface of the tool with oil, then carefully fit the oil seal to it.
  - Tap the seal into place, garter spring towards the crankshaft.

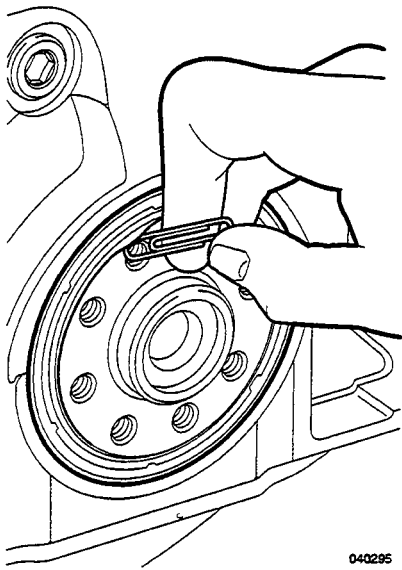

**Fig.4 Positioning seal lip**

- Check that the seal outer lip is seated correctly (i.e. not folded inwards).  
Re-position if necessary, using a small tool (e.g a paper clip) that cannot cut the seal.
7. Check that the dowel pin is correctly located, then fit the flywheel using new bolts and tighten them to the correct torque, restraining the flywheel with tool LDV 102. Remove the tool.
  8. Fit the clutch (see section 'Clutch Remove and Refit').

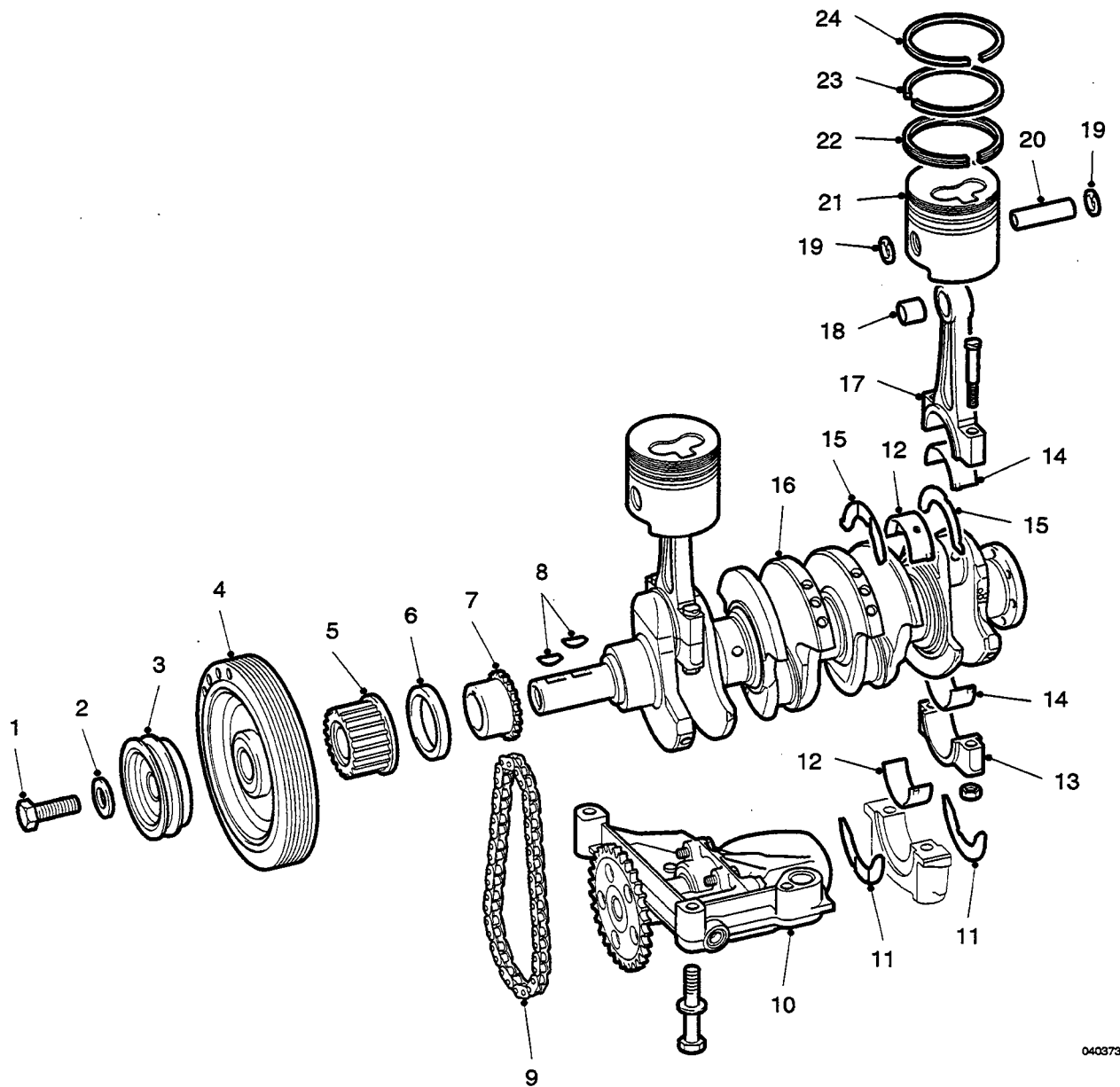

040373

**Fig.1 Crankshaft, connecting rods and pistons**

**CRANKCASE**

- |                               |                                 |                      |
|-------------------------------|---------------------------------|----------------------|
| 1. Bolt                       | 9. Oil pump drive chain         | 17. Connecting rod   |
| 2. Washer                     | 10. Oil pump                    | 18. Small end bush   |
| 3. Vacuum pump pulley         | 11. Thrust washers – lower half | 19. Snap ring        |
| 4. Crankshaft damper / pulley | 12. Main shell bearing          | 20. Gudgeon pin      |
| 5. Crankshaft belt pulley     | 13. Big end bearing cap         | 21. Piston           |
| 6. Oil seal                   | 14. Big end shell bearing       | 22. Oil control ring |
| 7. Oil pump drive sprocket    | 15. Thrust washers – upper half | 23. Compression ring |
| 8. Keys                       | 16. Crankshaft                  | 24. Compression ring |

## CRANKCASE

**Tools required:** 18G 1627A, 18G 1628A, 0480066, 0480080 (LST 122), 1210504 (18G 1507), LDV 102, LDV 104.

### Dismantling

*A number of operations can be carried out on the crankcase in situ. The following operations assume that the engine has been removed from the vehicle.*

1. Remove the timing belt (see section 'Timing Belt Remove').
2. Remove the cylinder head (see section 'Cylinder Head Remove').
3. Fit the flywheel locking tool LDV 102: remove the crankshaft pulley and recover its key.
4. Remove the flywheel (see section 'Flywheel'), and discard the bolts.
5. Remove the sump and clean off all sealant.

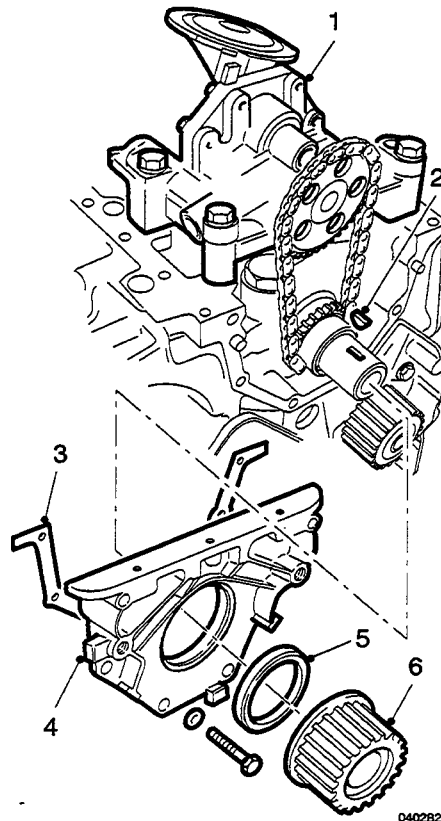

**Fig.2 Oil seal housing**

1. Oil pump
  2. Key
  3. Housing gasket (if fitted)
  4. Oil seal housing
  5. Crankshaft front oil seal
  6. Pulley
6. Remove the crankshaft front oil seal housing. Remove and discard the oil seal, and the gasket if fitted.

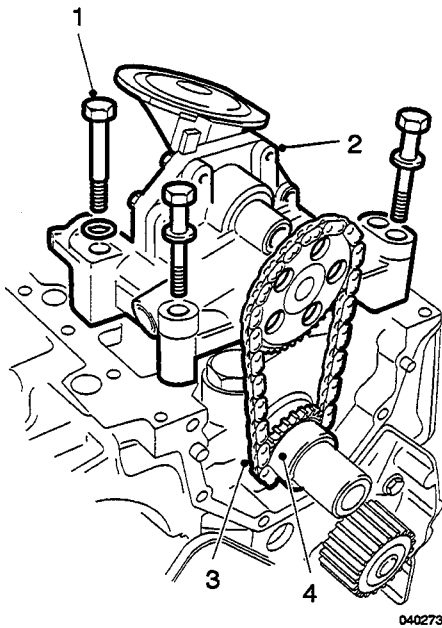

**Fig.3 Oil pump**

1. Centralising dowel bolt
2. Oil pump assembly
3. Drive chain
4. Crankshaft sprocket.

7. To remove the oil pump:

- Mark direction-of-rotation on chain drive.
  - Remove the 3 bolts securing the pump.
- NOTE:** Rear bolt is a centralising dowel bolt.
- Slide the assembly forwards together with the crankshaft sprocket and chain. Recover the sprocket drive key.

For oil pump inspection see section 'Lubrication System'.

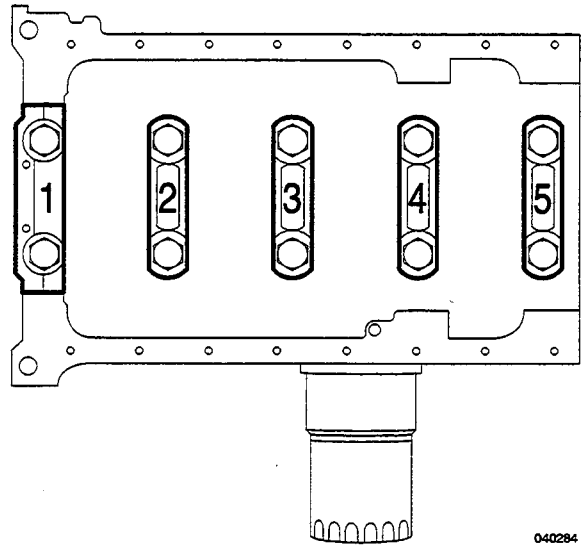

**Fig.4 Main bearing cap identification**

8. To remove the crankshaft:

- **CAUTION: Do not use a punch to mark caps.**

**NOTE:** No.1 piston and connecting rod assembly is at rear (flywheel end) of engine.

- Note the identification numbers on the main bearing caps (read from fuel injection pump side).
- **NOTE:** No.1 cap is at rear (flywheel end) of engine.
- Remove the main bearing caps. Note the dowels in No.1 cap, and the thrust washers in No.2 cap.
- Lift out the crankshaft.
- Recover the upper halves of the thrust washers in No.2 bearing, and the main bearing shells.

9. Carefully tap out the pistons and connecting rods.

10. Remove the water pump and any ancillary components.

**Inspection and Overhaul**

Thoroughly clean all component parts prior to inspection / overhaul.

## CYLINDER BLOCK

11. Degrease the block and remove all traces of old sealant.
12. Inspect the block for cracks and other damage.
13. Assess the condition of the cylinder bores for excessive wear. Rectify / re-bore as necessary.
14. Machining:
  - The top face of the block cannot be machined as this would affect the piston protrusion.

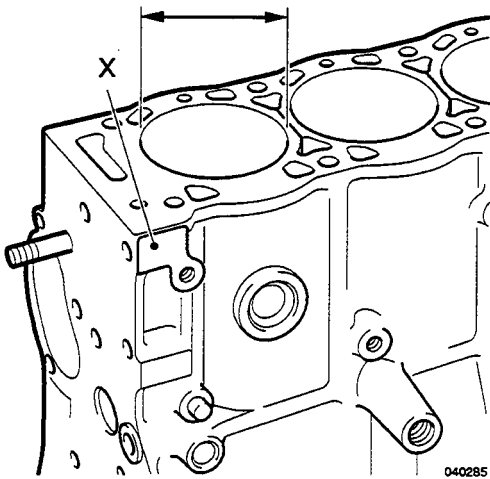

**Fig.5 Cylinder block machining**

- Bores can be machined and 3 piston oversizes are available.

Oversize R1 – + 0,20 mm

Oversize R2 – + 0,50 mm

Oversize R3 – + 0,80 mm

The size of the bores is stamped at point 'X' on the cylinder block.

No stamping or 'A1' indicates a standard bore size.

If the bores are machined oversize, the block must be stamped 'R1', 'R2', or 'R3' as appropriate. A similar marking will be found on oversize piston crowns.

See 'Data' for re-boring dimensions.

## CRANKSHAFT

15. Degrease the crankshaft and check that the oil ways are not restricted or blocked.
16. Examine the crank pins, main bearing journals and thrust washer bearing faces for signs of wear, scores, grooves and overheating. Examine the spigot bush for wear or damage.

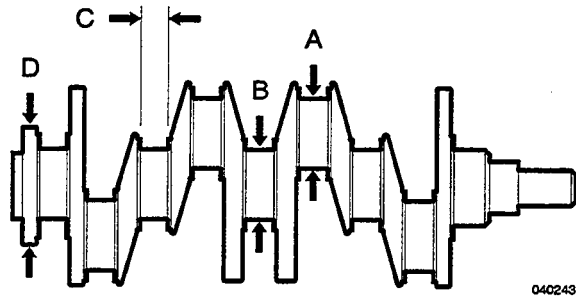

**Fig.6 Crankshaft**

17. Crankshaft machining is permissible;

- One undersize of main and big end bearing shells available. Main (dimension 'B') and big end (dimension 'A') undersizes – 0,30 mm. Undersize main and big end bearing shells are identified with the size stamped on the steel side.
- 3 thrust washer oversizes are available to adjust crankshaft end-float 'C'.
- The rear oil seal contact surface 'D' can be machined undersize by up to 0,20 mm to eliminate grooving.

See 'Data' for machining dimensions.



## PISTONS AND CONNECTING RODS

18. Degrease the piston and connecting rod assemblies.
19. Before dismantling, check for wear in the gudgeon pin area. If pistons are to be refitted, make temporary marks to indicate cylinder number (no.1 piston at the rear).

**NOTE:** Replacement pistons are only available as a set of 4.

20. Remove one of the retaining snap rings and push out the gudgeon pin to release each piston from its connecting rod.
21. Examine connecting rod small end bushes, and check the oil splash feed hole for blockage.
22. Examine the pistons and rings for wear, damage, scuffing etc. Renew only as a set of 4.

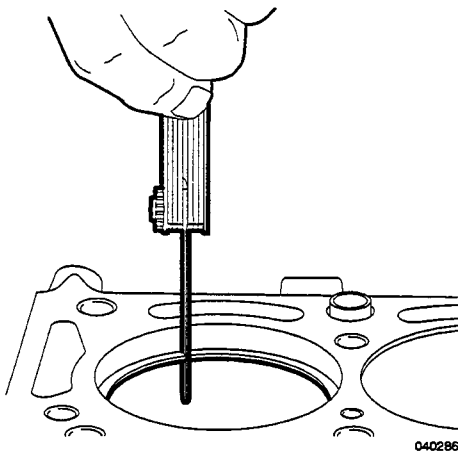

**Fig.7 Measuring piston ring gap**

23. Replacement piston rings are available. Before fitting to the piston, check the ring gaps as follows:
  - Fit each ring in turn approximately 15 mm (0.5 in.) down the bore of the cylinder to which it will be fitted. Ensure it is square in the bore by pushing it into position with the piston crown.
  - Measure the ring gap with feeler gauges and compare with the figures given in 'Data'.
  - If the gap is too large, check for bore wear.

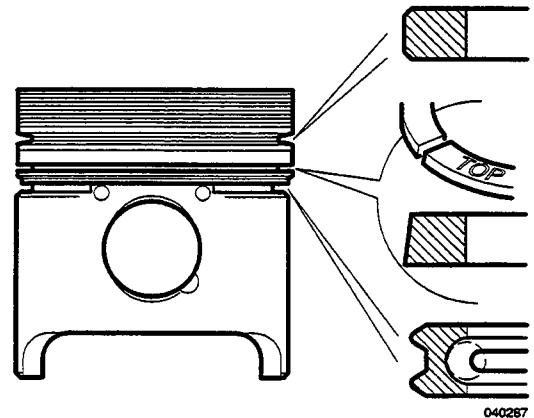

**Fig.8 Piston rings**

24. Fit the piston rings using a suitable ring expander.
  - Bottom (oil control) scraper ring can be fitted either way round.
  - Middle (compression) ring has tapered face. Top face of ring is marked 'TOP'.
  - Top (compression) chrome ring can be fitted either way round.

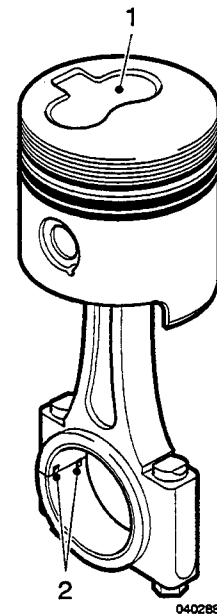
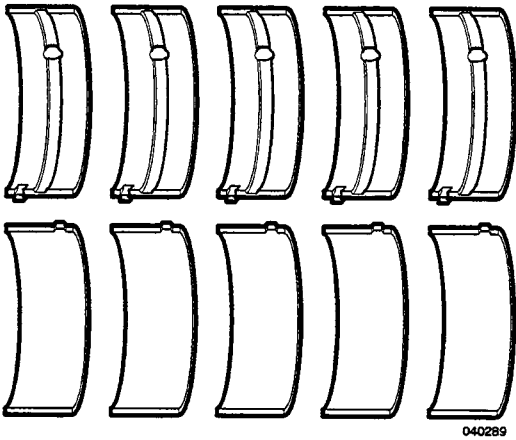

**Fig.9 Piston and connecting rod.**

1. Piston crown recess
  2. Bearing shell tab recesses
25. Lubricate the gudgeon pin and fit each piston to its connecting rod. Ensure that the piston crown recess is on the same side as the bearing shell tab recesses when assembled.

## Crankcase Re-build

Lubricate all components before fitting.



**Fig.10 Main bearing shells**

26. Fit new upper half main bearing shells (with oil grooves) of the correct size into the block.

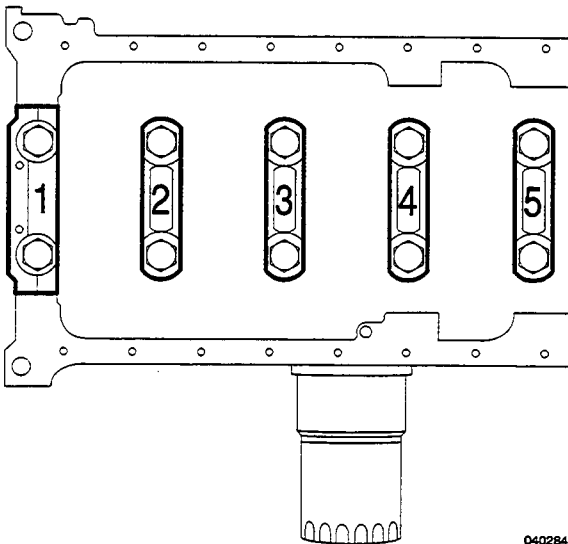
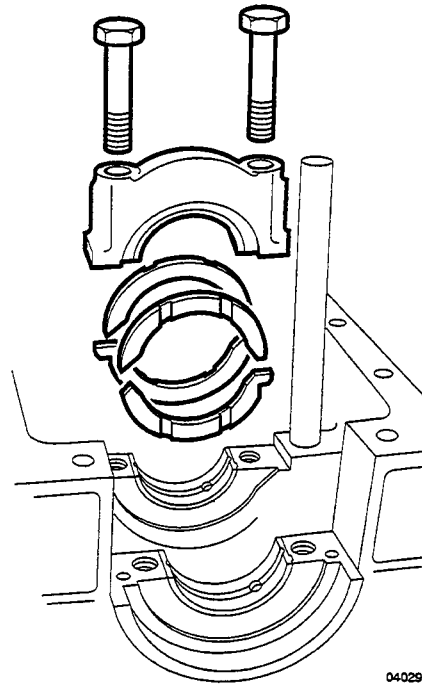

**Fig.11 Main bearing cap identification**

27. Carefully lower the crankshaft into place, and fit Nos.3, 4, and 5 main bearing caps.

**NOTE:** Cap identification numbers to be read from the fuel injection pump side; no.5 cap at front of engine.

Tagged ends of shell bearings must be on the same side.



**Fig.12 Crankshaft thrust washers**

28. Locate the upper thrust washers in the block at No.2 journal, ensuring the grooved thrust faces are towards the crankshaft.
29. Locate the lower thrust washers in No.2 main bearing cap, grooved thrust faces outwards.
- Fit the cap.



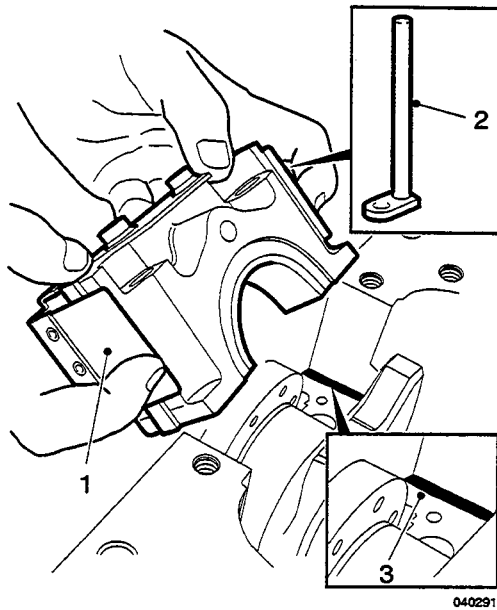

040291

**Fig.13 Fitting No.1 main bearing cap**

1. Tool 18G 1627A
2. Rubber seal
3. Loctite 518 sealant

30. Fit the rear (No.1) main bearing cap as follows:

- Fit new rubber seals to the cap, ensuring each seal is located on its dowel pin.
- Lubricate the side plates of tool 18G 1627A and carefully fit it over the cap. Secure the tool with 2 suitable bolts.
- Apply a light coat of Loctite 518 sealant to the block at the bearing cap contact area.
- Fit the cap by squeezing the sides of tool 18G 1627A to compress the rubber seals, then insert it at an angle of approximately 45°. Carefully bring the cap to the vertical position and push it into place. Fit the cap bolts and remove the tool by sliding it out rearwards.

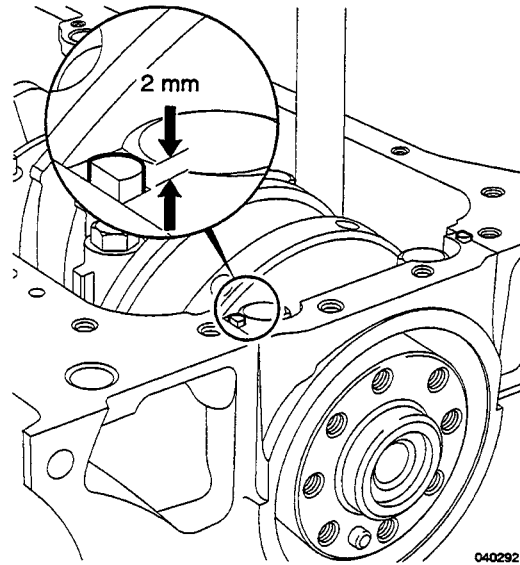

040292

**Fig.14 Rubber seal protrusion**

- Check the protrusion of the rubber seals, which should be approximately 2 mm (0.08 in.). If the protrusion is greater than this, the seal has been stretched during fitting and the procedure must be repeated.
31. Tighten all the bearing cap bolts to the correct torque, and check that the crankshaft can turn freely.

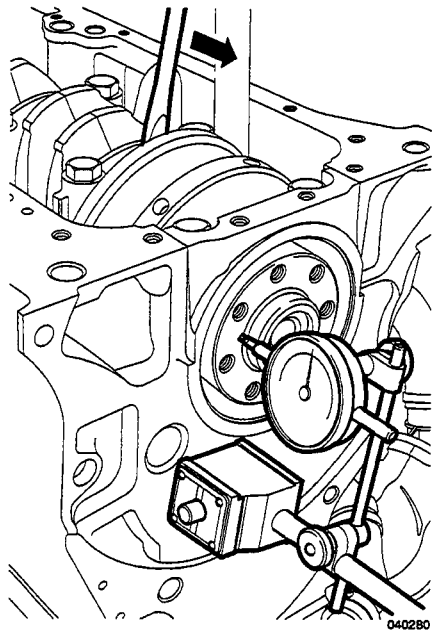

**Fig.15 Measuring crankshaft end-float**

32. Check the crankshaft end-float as follows:
- Position a dial gauge on the end of the crankshaft.
  - Push the crankshaft fully in both directions and note the end-float recorded on the gauge.
  - Compare the measurement obtained with the figure given in 'Data'.
  - If the end-float is excessive, remove No.2 main bearing cap and fit appropriate oversize thrust washers. 3 oversizes are available.
  - Re-check the end-float.

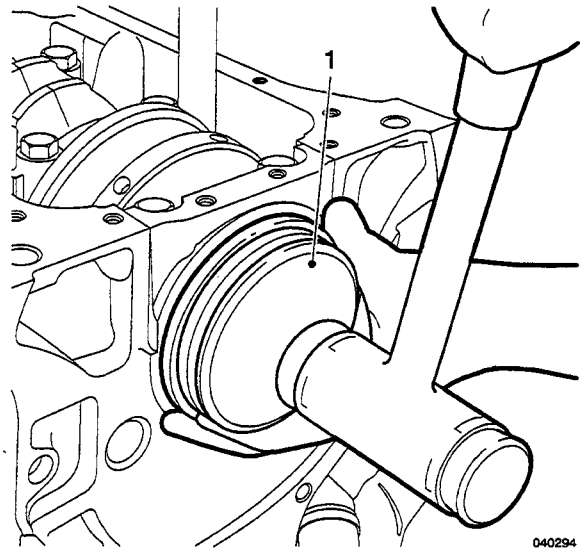

**Fig.16 Fitting crankshaft rear oil seal**

1. Tool 18G 1628A
33. Fit the crankshaft rear oil seal as follows:
- Examine the smaller outside diameter surface of tool 18G 1628A to check that there are no imperfections that could damage the oil seal.
  - Smear the surface of the tool with oil, then carefully fit the oil seal to it.
  - Tap the seal into place, garter spring towards the crankshaft.

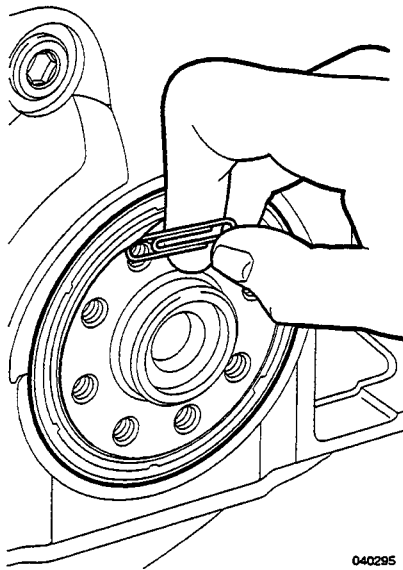

040295

**Fig.17 Positioning seal lip**

- Check that the seal outer lip is seated correctly (i.e. not folded inwards). Re-position if necessary, using a small tool (e.g. a paper clip) that cannot cut the seal.

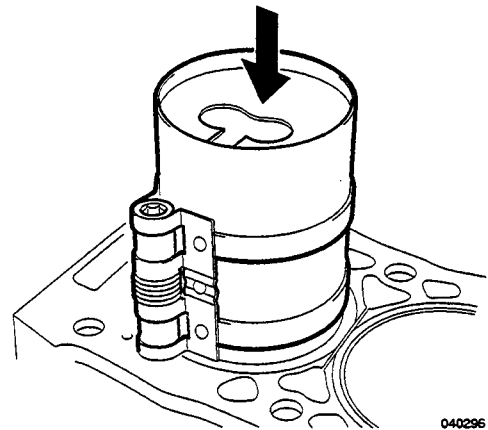

040296

**Fig.18 Fitting piston and connecting rod**

34. Fit each piston and connecting rod assembly as follows:

- Fit protective sleeves to the big end bolts.
- Fit new bearing shells in the big end.
- Position the gap in the scraper ring over the gudgeon pin, and space the other two ring gaps at 120° angles to the scraper ring.
- Lubricate and fit a piston ring compressor, and fit the piston and connecting rod assembly in its nominated bore, ensuring the piston crown recess is on the fuel injection pump side of the engine.
- Fit the bearing cap, making sure it is the correct way round (shell bearing tags on the same side), and tighten the nuts to the correct torque as follows:

Pre-tighten both nuts to

**20 ± 2 Nm (15 ± 1.5 lbf ft).**

Tighten both nuts a further 70° using angular torque gauge 0480080 (LST 122).

Check with torque wrench that nut tightness is now

**50 ± 10 Nm (37 ± 7 lbf ft).**

- After all the pistons have been fitted, check that the crankshaft turns freely.

35. Check that the flywheel dowel is fitted correctly, then fit the flywheel using new bolts and tighten them to the correct torque.

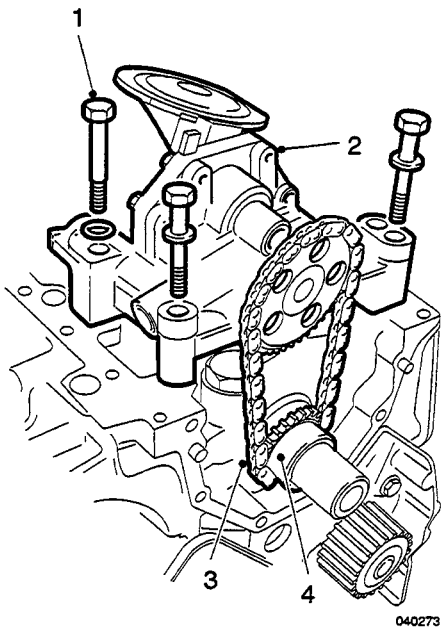

**Fig.19 Fitting oil pump**

1. Centralising dowel bolt & washer
2. Oil pump assembly
3. Drive chain
4. Crankshaft sprocket

36. To fit the oil pump:

- Assemble the pump, drive chain and sprocket, noting the direction-of-rotation mark made on the chain during removal.
- Slide the sprocket over the crankshaft nose and position the pump on the block.
- Fit the sprocket key, and hold it in place with grease.
- Fit the pump securing bolts, noting the position of the centralising dowel bolt with its special thin washer.
- Tighten the bolts to the correct torque.

37. The crankshaft front oil seal housing may be fitted either using a gasket or by applying Loctite 518 to the sealing face. Tighten the securing bolts to the correct torque.

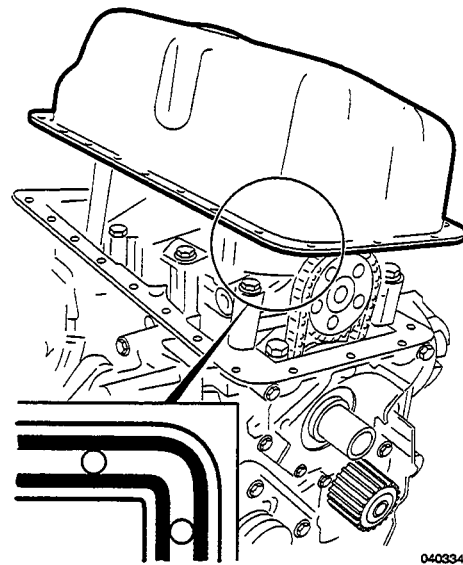

**Fig.20 Applying sealant to sump**

38. Apply 2 beads of Rhodoseal 5661 sealant to the sump, one on either side of the raised rib as illustrated, then fit the sump and tighten the securing bolts to the correct torque.

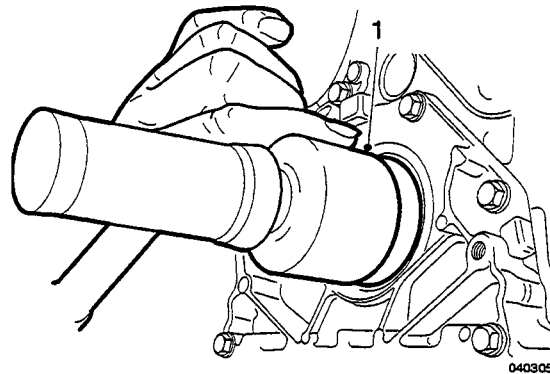

**Fig.21 Fitting crankshaft front oil seal**

1. 1210504 (18G 1507)

39. Lubricate the lip of a new crankshaft front oil seal and fit it in the housing using 1210504 (18G 1507), garter spring towards the cylinder block. Tap the seal into position until it is flush with the front face of the housing.

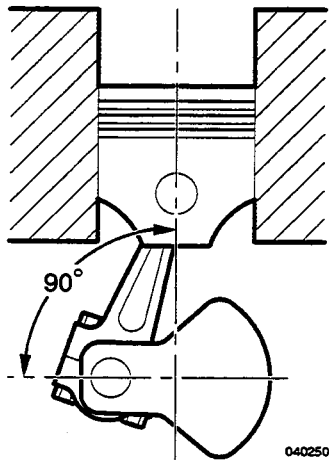
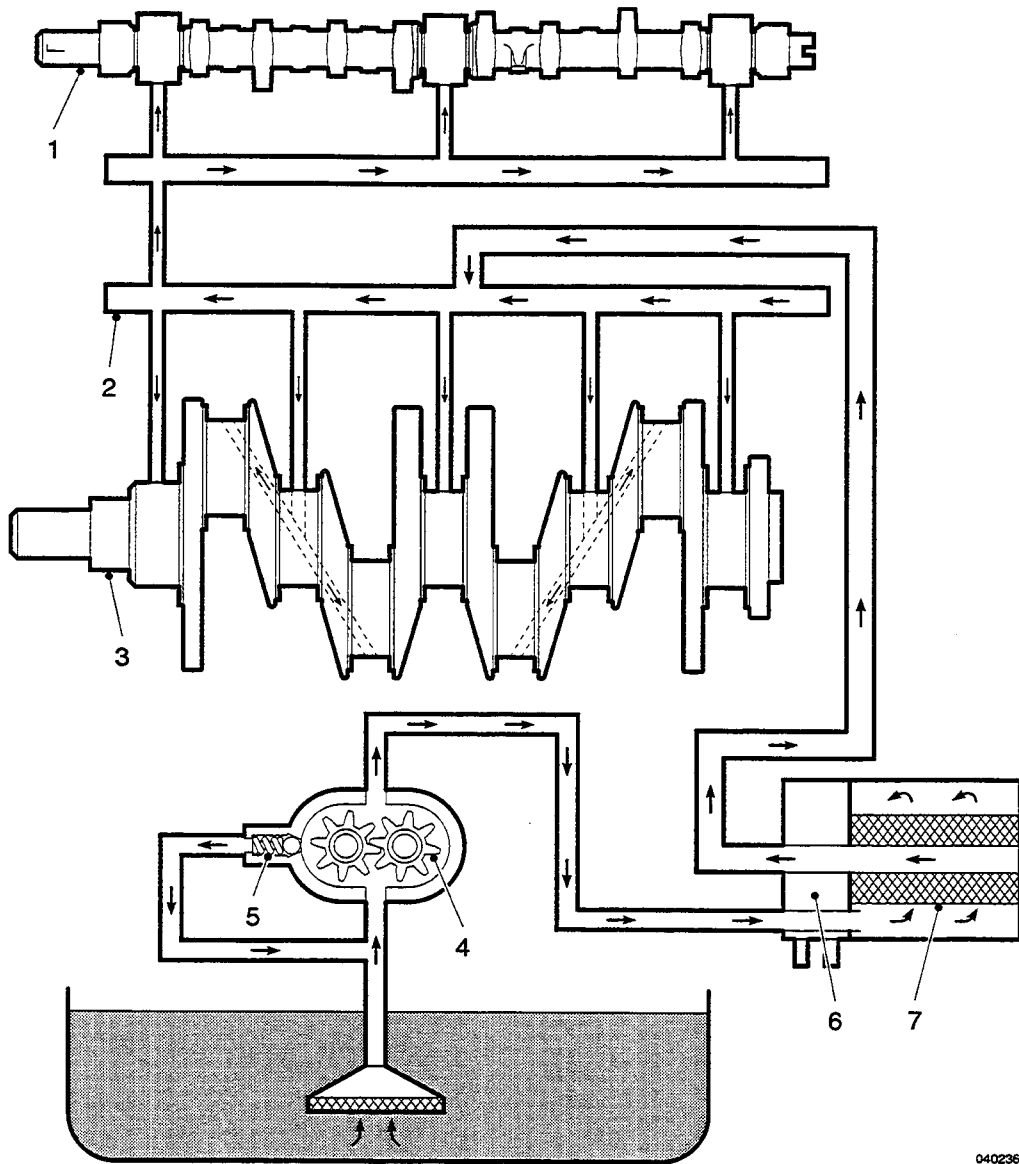

**Fig.22 Crankshaft in 'safe' position**

40. Turn the crankshaft until all the pistons are half way up their bores in the 'safe' position.
41. Fit the cylinder head (see section 'Cylinder Head Refit').
42. Turn the camshaft until the timing bolt can be inserted through the pulley.
43. Turn the crankshaft **clockwise** until the timing pin LDV 104 can be fitted in the flywheel.
44. Fit the tensioner plunger housing, the tensioner and the timing belt etc. and rebuild the front end as described in the section 'Timing Belt Refit'.
45. Check/adjust the fuel injection pump timing (see the section 'Fuel System'), if dynamic timing equipment is not available.
46. Prior to fitting the gearbox, check that the two dowel pins are correctly located and fit the rear engine plate.

# LUBRICATION SYSTEM

LUBRICATION SYSTEM



040236

**Fig.1 Lubrication system**

1. Camshaft
2. Main oil gallery
3. Crankshaft
4. Oil pump
5. Pressure relief valve
6. Modine oil cooler
7. Oil filter

## OIL CIRCULATION

The gear type oil pump is located on the underside of the cylinder block, and is chain driven by the crankshaft. Oil is picked up from the sump via an oil strainer. The oil pump housing contains the pressure relief valve which returns excess oil to the pump inlet.

The pump supplies the main oil gallery in the engine via a modine oil cooler and a full flow filter. The filter contains a valve arrangement to enable it to be by-passed if it should become blocked. Also incorporated in the filter is an anti-drain valve.

The main oil gallery supplies oil to:

- The five crankshaft main bearings, which in turn supply the big ends.
- A gallery in the cylinder head which supplies the three camshaft bearings.

Piston bores and small end bushes are lubricated by splash feed, and a drilling in the top of each connecting rod ensures an adequate supply of oil to the small ends.

## OIL PUMP

### Inspection

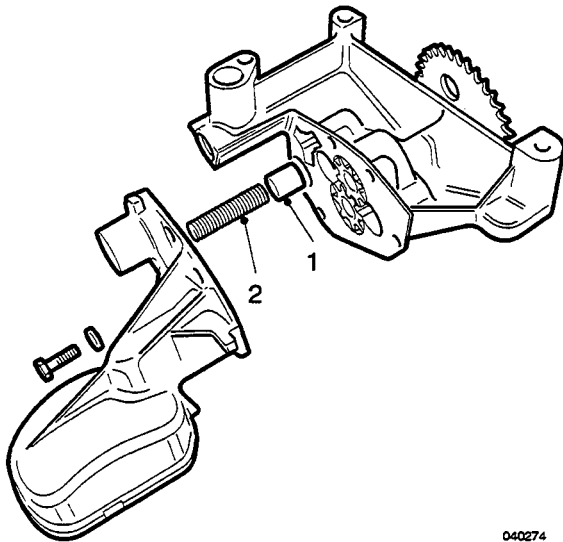

**Fig.1 Oil pump**

1. Relief valve
2. Spring

1. Remove the securing bolts to separate the oil pump casings. Remove the pressure relief valve and spring.

2. Clean all components and examine for wear and damage. Inspect the gears and check for free rotation.
3. Inspect the relief valve for free action. Check the free length of the spring.
4. Flush through pick-up filter.
5. Renew components as necessary, and rebuild pump.

## MODINE OIL COOLER

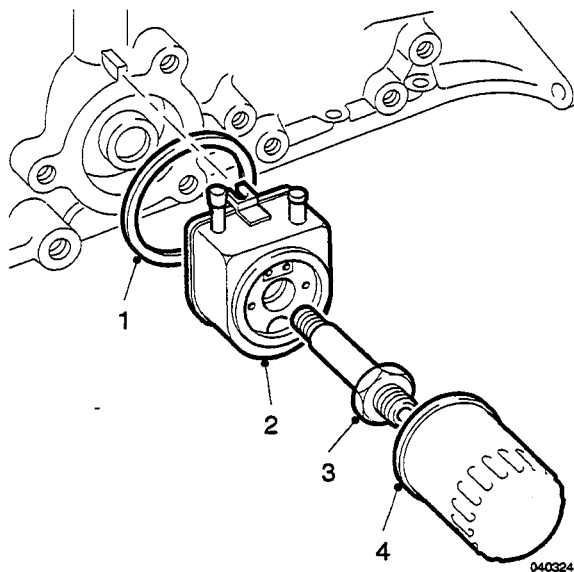

**Fig.2 Modine oil cooler**

1. Sealing ring
2. Modine oil cooler
3. Fixing
4. Oil filter

If the oil cooler is removed, the sealing ring must be renewed.

To maintain oil cooler alignment, it is positively located over a lug cast on the cylinder block. Tighten the securing fixing to the correct torque.



## FUEL SYSTEM

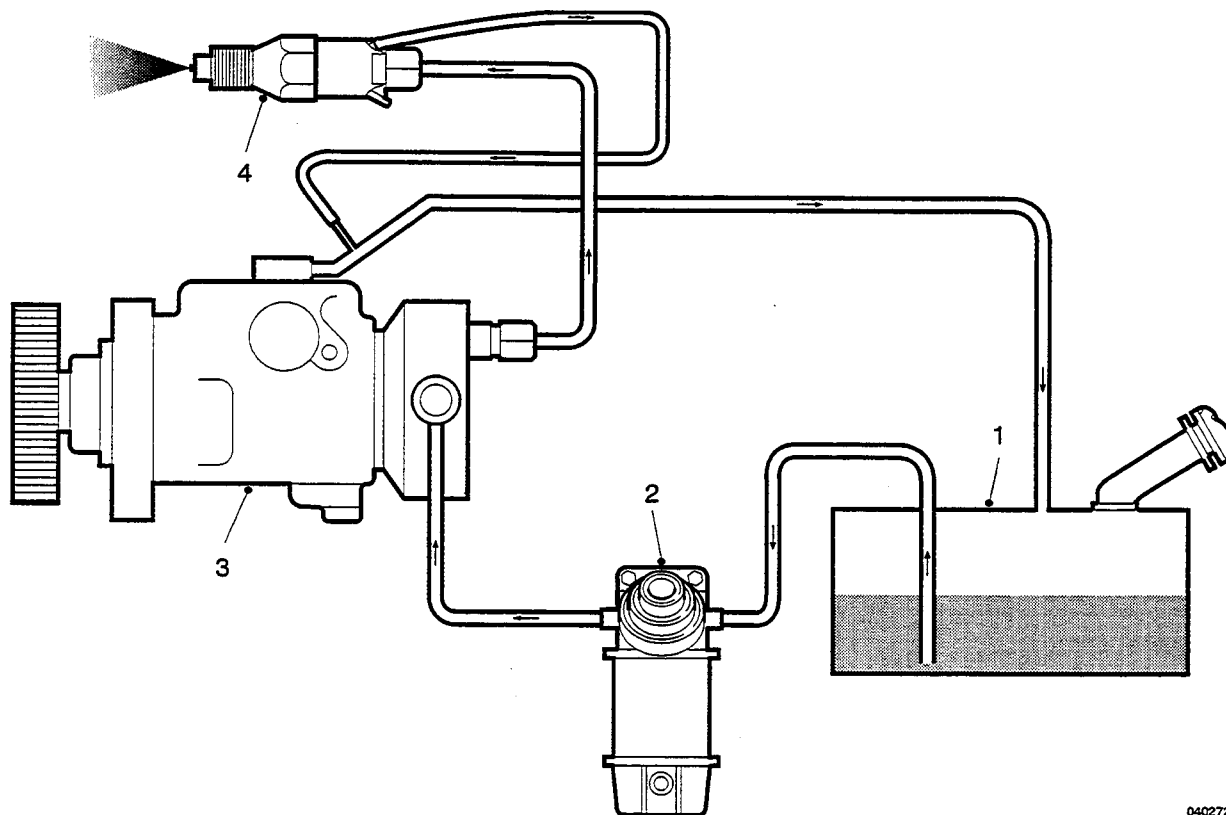

040272

**Fig.1 Fuel system**

1. Fuel tank
2. Fuel filter
3. Fuel injection pump
4. Injector

### OPERATION

A separate fuel lift pump is not necessary, as fuel is drawn into the system by a transfer pump inside the fuel injection pump.

The fuel injection pump is driven by the timing belt; it draws fuel from the fuel tank, through the replaceable element filter. The filtered fuel enters the pump via a banjo connection on the hydraulic head. The transfer pump raises the fuel to a pressure controlled to a pre-determined level by a regulator valve.

The injection pump rotor in the hydraulic head distributes the fuel to each injector, the settings of which provide the final pressure rise. The quantity of fuel delivered into each combustion chamber is dependent on throttle position and engine speed.

Excess fuel from the injectors and from the injection pump passes through a return pipe directly to the fuel tank.



## FUEL INJECTION PUMP ADJUSTMENTS

**NOTE:** If all 4 adjustments are required, it is recommended that they be made in the sequence shown below.

### Throttle Cable – Check / Adjust

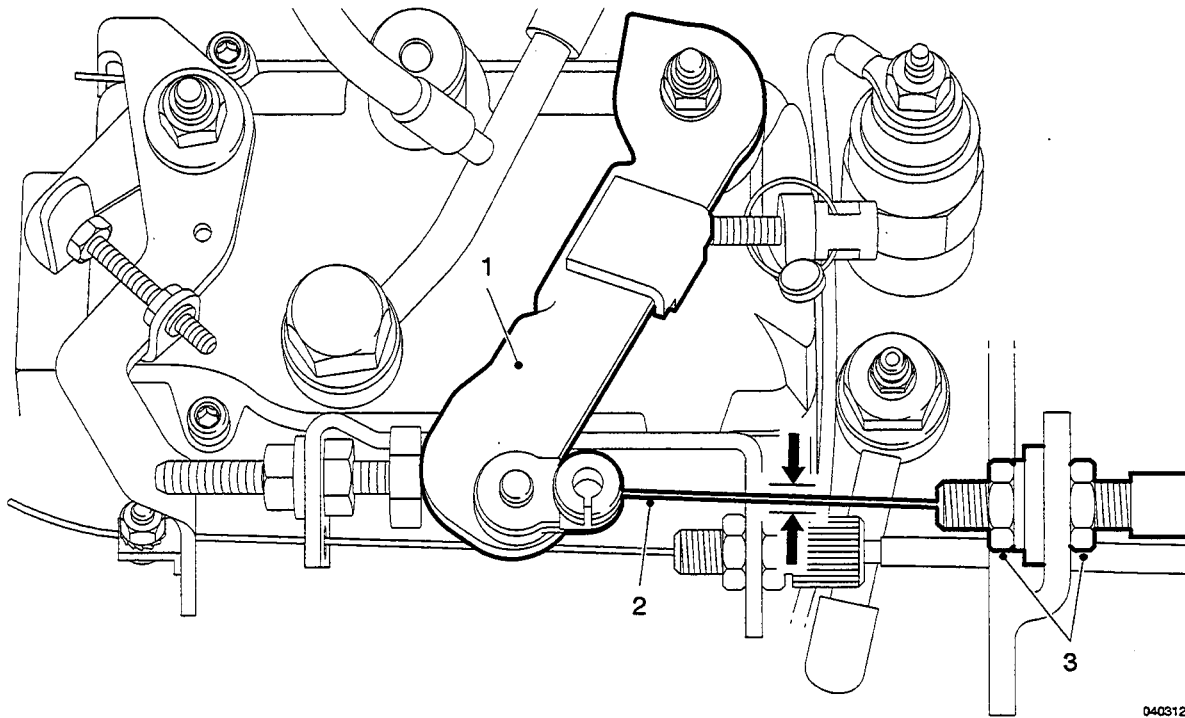

040312

**Fig.1 Adjusting throttle cable**

1. Throttle lever
2. Throttle cable
3. Cable adjusters

1. Check that a small amount of free play exists at the throttle cable (2).
2. Get an assistant to depress the throttle pedal fully. Check for full movement of the throttle lever (1) against the maximum speed stop screw. Rectify as necessary.

## Idle Speed – Check / Adjust

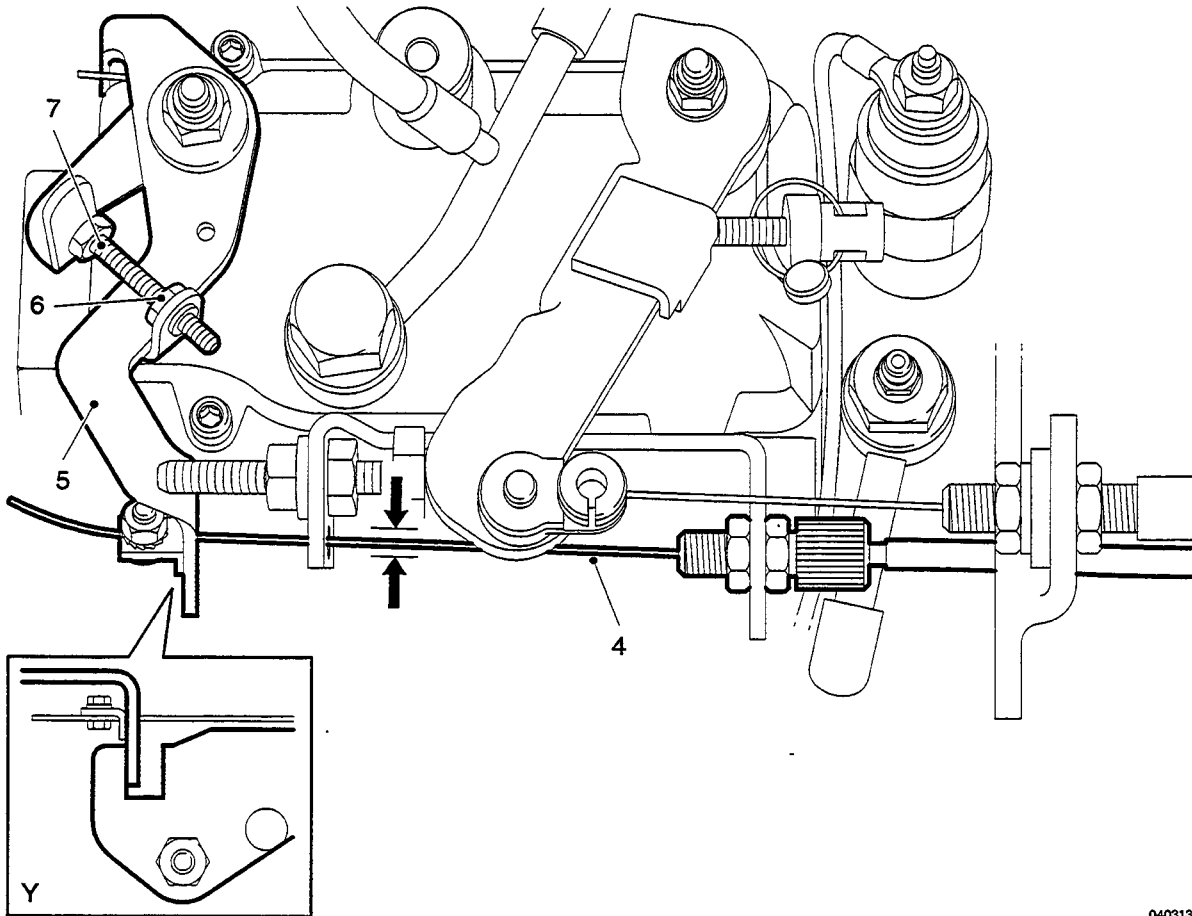

040313

**Fig.2 Adjusting idle speed**

4. Fast idle cable
  5. Fast idle control lever
  6. Locknut
  7. Idle speed screw
1. Prepare suitable equipment to enable engine speed to be recorded accurately e.g. Dieseltune DX 801 (1210514).
  2. Start the engine and warm to normal running temperature.
  3. Check the throttle cable adjustment (see 'Throttle Cable').
  4. Check there is free play in the fast idle cable (4), and the fast idle control lever (5) is against its front stop (position 'Y').
  5. Check the idle speed which should be  $800 \pm 50$  RPM. If incorrect, adjust as follows.
    - Loosen the locknut (6) and adjust the idle speed screw (7) to set the correct idle speed.
    - Tighten the locknut and re-check the idle speed.
  6. Stop the engine.

### Automatic Fast Idle – Check / Adjust

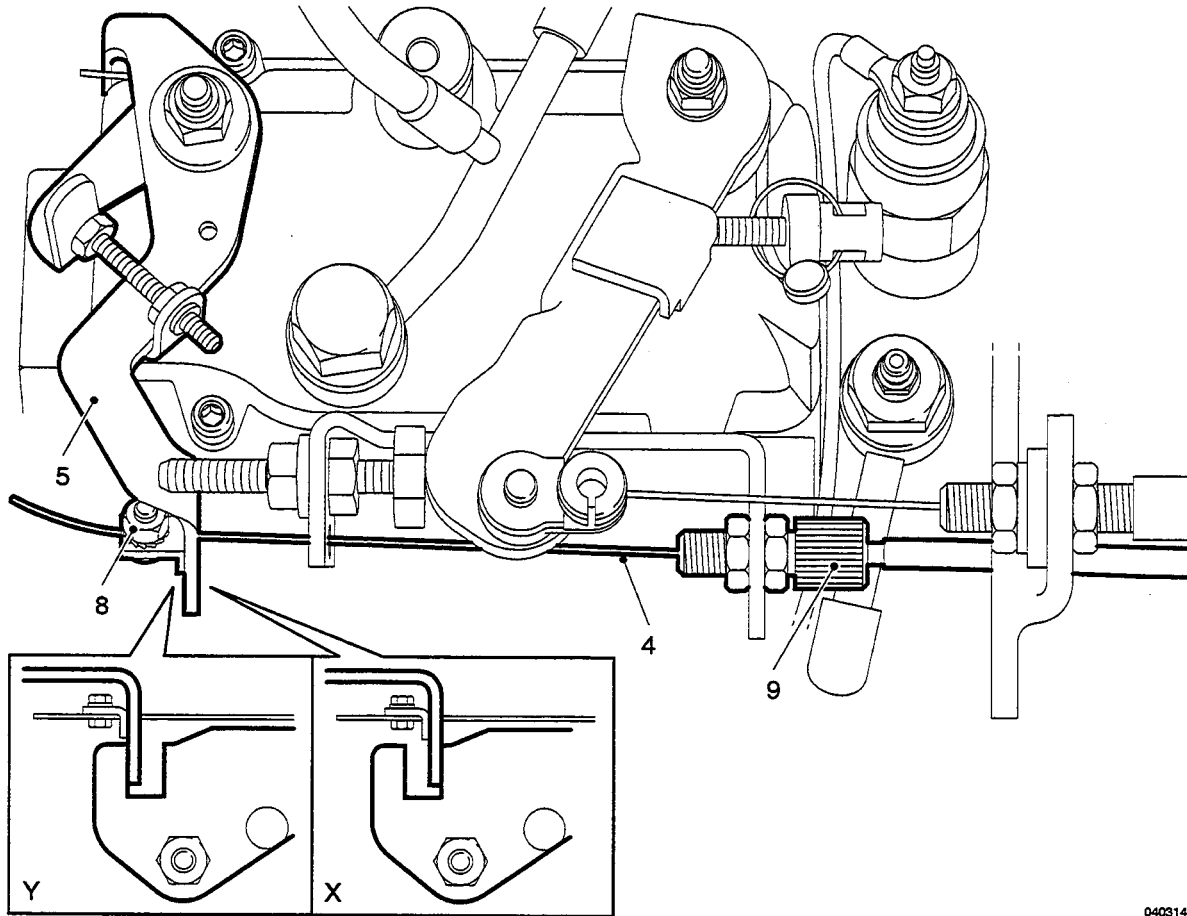

FUEL SYSTEM

040314

**Fig.3 Adjusting automatic fast idle**

- 4. Fast idle cable
- 5. Fast idle control lever
- 8. Fast idle cable clamp
- 9. Fast idle cable adjusters

**If the engine is cold.**

1. The fast idle cable (4) should hold the control lever (5) against its rear stop (position 'X').
2. If incorrect, adjust as follows:
  - Re-position the cable clamp (8) until the lever abuts against its rear stop.
  - Make a final adjustment using cable adjusters (9).

**If the engine is hot:**

1. Check there is free play in the fast idle cable (4), and that the fast idle control lever is against its front stop (position 'Y').
2. Check the idle speed (see section 'Idle Speed Adjustment').
3. With the engine still running, move the fast idle control lever (5) against its rear stop (position 'X') and note the increase in engine speed. It should increase by approximately 200 RPM above the idle speed.
4. If incorrect, check for freedom of movement of linkages and the stop lever.

## Anti Stall – Check / Adjust

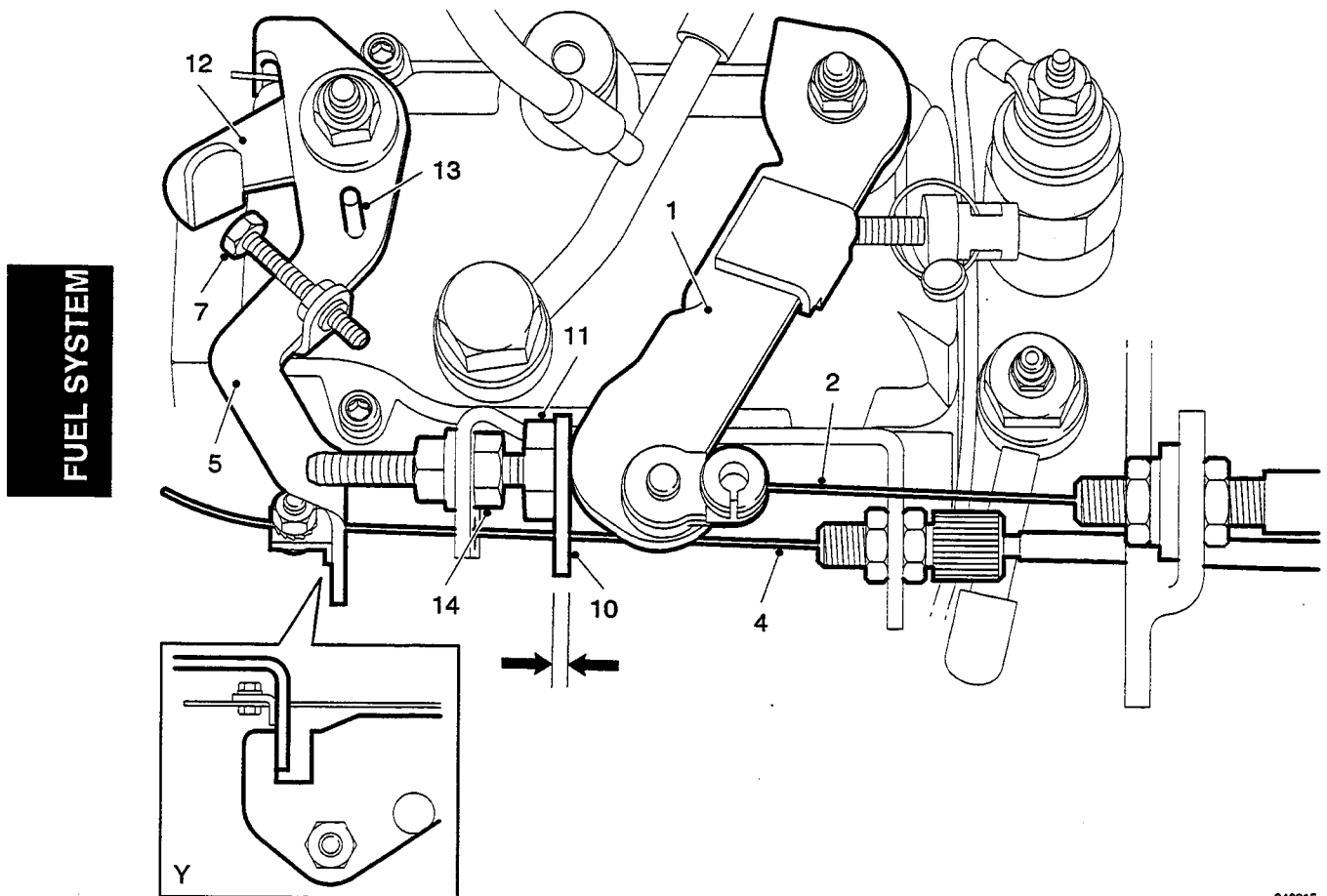

040315

**Fig.4 Adjusting anti-stall**

- |                            |                      |                   |
|----------------------------|----------------------|-------------------|
| 1. Throttle lever          | 7. Idle speed screw  | 13. 3 mm dia. rod |
| 2. Throttle cable          | 10. Spacer           | 14. Locknut       |
| 4. Fast idle cable         | 11. Anti-stall screw |                   |
| 5. Fast idle control lever | 12. Stop lever       |                   |

- With the engine off, check there is free play in the fast idle cable (4), and the fast idle control lever (5) is against its front stop (position 'Y').
- Disconnect the throttle cable (2), and place a 3 mm (0.12 in.) spacer (10) between the screw (11) and the throttle lever (1).
- Turn the stop lever (12) against spring pressure and fit a 3 mm diameter rod (13) in the hole in the fast idle control lever (5).
- Start the engine and note the engine speed which should be  $900 \pm 50$  RPM. If incorrect adjust as follows.
- Loosen locknut (14), adjust the anti-stall screw (11) and re-tighten the locknut.
- Remove the rod (13), and check that the stop lever (12) returns against the head of the idle speed screw (7).
- Remove the spacer (10) and note the idle speed which should be  $800 \pm 50$  RPM. Re-adjust if necessary (see section 'Idle Speed Adjustment').
- Pull the stop lever (12) from its stop by 0,5 – 1,00 mm; the engine speed should drop. If not, repeat all the above adjustment instructions.
- Connect the throttle cable and adjust its length (see section 'Throttle Cable Adjustment').

## FUEL INJECTION PUMP TIMING

### Check & Adjust, Static Procedure.

**NOTE:** Fuel injection pump timing can be checked dynamically, but for greatest accuracy it is recommended that the timing is checked and adjusted statically, as described below.

**Tools required:** LDV 104, 0480066.

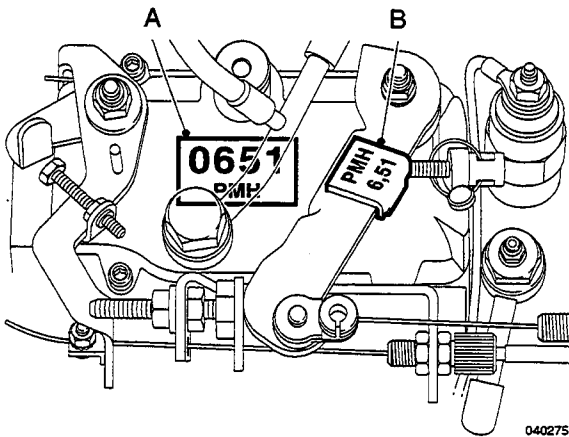
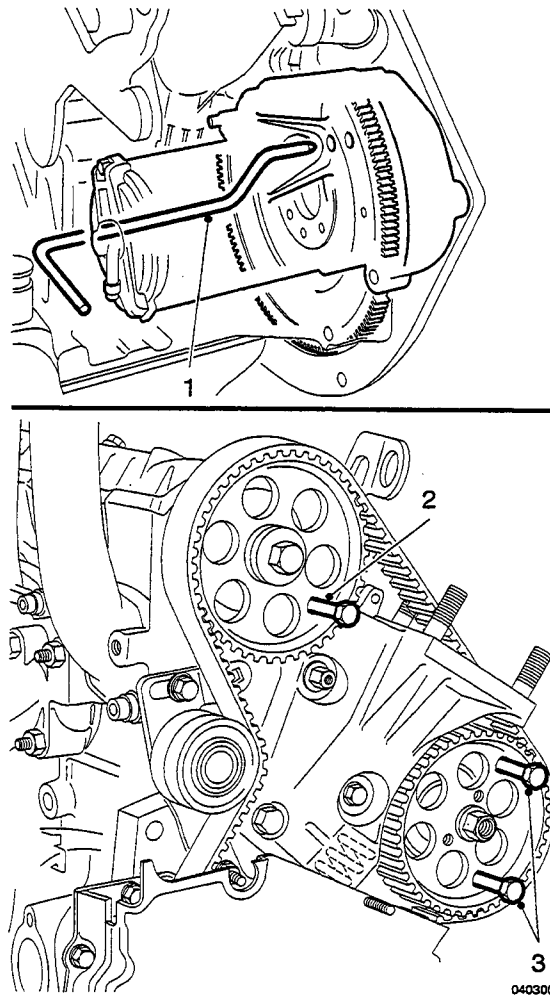

**Fig.1 Fuel injection pump timing setting**

**NOTE:** Every pump is individually timed. The timing setting is marked on a label (A) on the pump body, and also on a plate (B) attached to the throttle lever.

*If timing the fuel injection pump in the vehicle, the following operations must be carried out first:*

1. *Disconnect the batteries, negative terminals first.*
2. *Disconnect the intake air duct.*
3. *Remove the timing belt inspection plate and two belt upper covers.*



**Fig.2 Fitting timing pin and timing bolts**

1. Flywheel timing pin LDV 104
2. Camshaft timing bolt
3. Injection pump timing bolt
4. Turn the crankshaft clockwise to no.4 cylinder (front of engine) TDC position. Fit the timing pin LDV 104 in the flywheel location. Fit suitable length M8 bolts in the camshaft pulley and fuel injection pump pulley timing holes, finger tight only.

**NOTE:** This operation confirms the correct timing relationship between the crankshaft, camshaft and fuel injection pump.

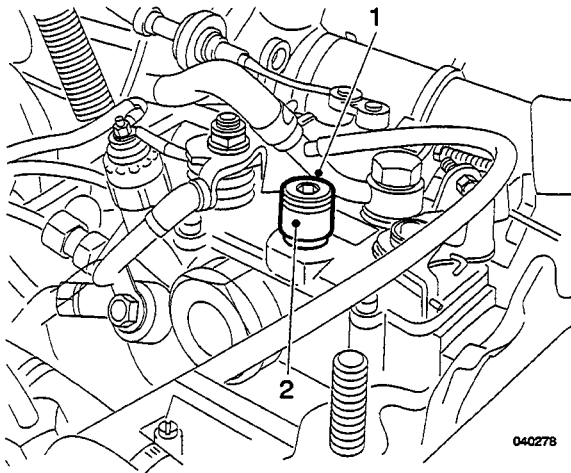

**Fig.3 Fuel injection pump**

1. Threaded plug
  2. Timing connector
5. Thoroughly clean the top of the fuel injection pump. Remove the threaded plug '1' to gain access to the timing hole in the timing connector '2'.

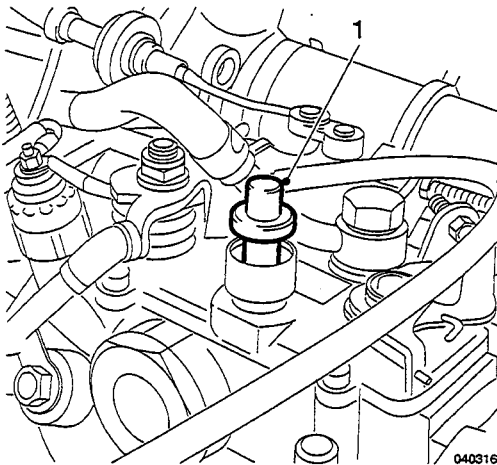

**Fig.4 Timing pin fitted**

1. Timing pin of tool 0480066
6. Insert into the timing connector the timing pin from tool 0480066.
7. Remove the camshaft and fuel injection pump timing bolts and the flywheel timing pin LDV104
8. Observe the timing pin 0480066, and turn the crankshaft **anti-clockwise** until the pin bottoms on the timing connector.

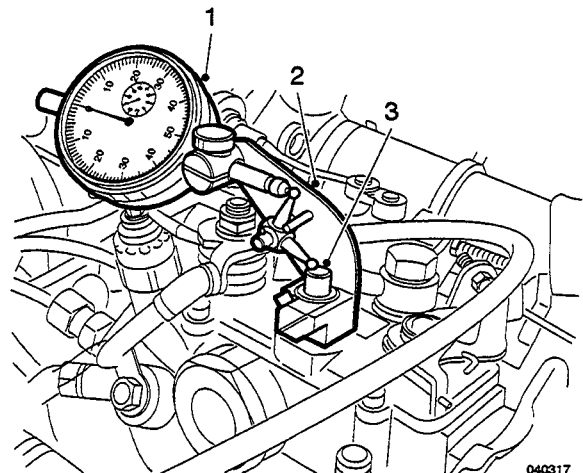

**Fig.5 Timing tool fitted**

1. Dial gauge
  2. 0480066 bracket
  3. 0480066 timing pin
9. Fit the bracket of tool 0480066 to the connector so that one arm of the tool crank rests on the pin already fitted.
10. Fit a dial gauge to the bracket, pushing the gauge in until it is pre-loaded by approximately 1 mm before tightening the clamping screw.

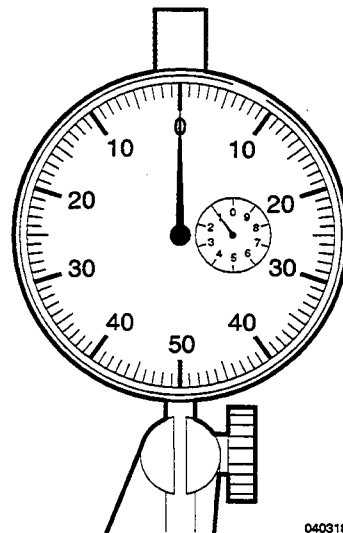

**Fig.6 Dial gauge reading (Example)**

11. Zero the gauge, and note the position of the small pointer (see fig.6).
12. Turn the engine **clockwise** until the timing pin LDV 104 can be fitted in the flywheel, noting the movement of the gauge needles, and in particular recording the reading when the timing pin is fitted.

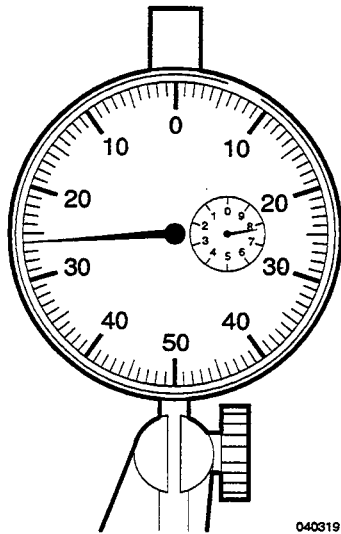

040319

**Fig.7 Dial gauge reading (Example)**

In the example shown in fig.7 the gauge reading is now 7,74 mm. Subtract from this figure the example reading previously noted 1,00 (see fig.6), and the result is 6,74 mm.

Compare this result with the figure marked on the pump.

If they are the same, the timing is correct.

In the example being checked the correct setting is 6,51 mm, and therefore must be adjusted as follows.

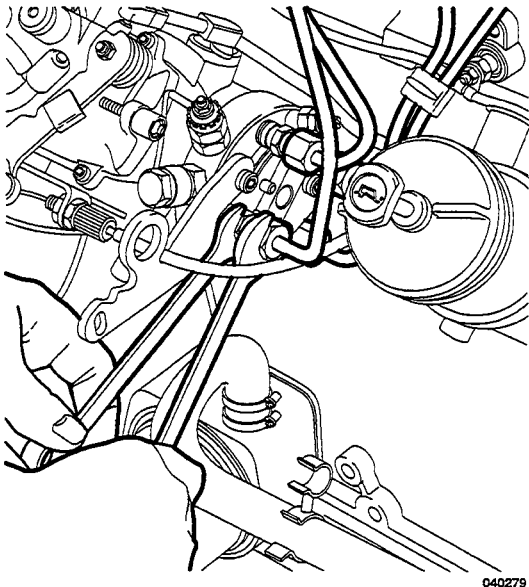

040279

**Fig.8 Slackening fuel injector pipes**

13. Slacken the 4 fuel injector pipes at the pump, making sure each union is restrained from turning while its nut is slackened.

14. Slacken the injector pump rear mounting and the 3 flange fixings at the front.
15. Turn the pump away from the engine as far as the adjustment slots will allow.

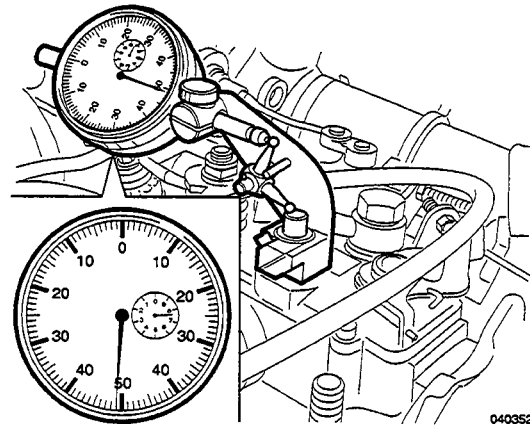
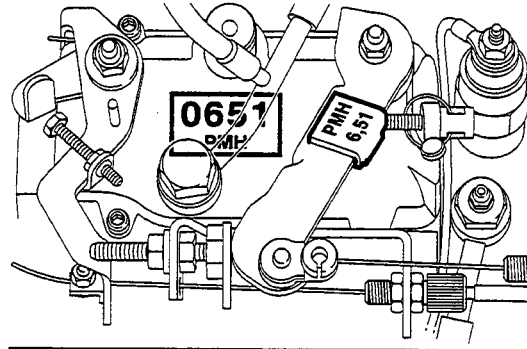

040352

**Fig.9 Timing figure, and gauge reading (Example)**

16. Slowly turn the pump towards the engine until the required gauge reading of 6,51 mm (7,51 – 1.00 mm) is obtained.

Tighten the 3 pump flange nuts.

17. The adjustment just made must be checked as follows:
  - Remove the flywheel timing pin LDV 104.
  - Turn the engine anti-clockwise until the timing pin of tool 0480066 bottoms in the timing connector. Check that the dial gauge has returned to the previously zeroed position. If incorrect, re-set the pre-load as in operation 11.
  - Turn the engine clockwise until the timing pin LDV 104 can be fitted in the flywheel.
  - Check that the gauge reads the correct timing figure, in our example 6,51 mm (7,51 – 1,00 mm).



- If incorrect, continue to re-adjust the pump and re-check until the correct timing position is obtained.

18. Tighten the pump rear mounting.
19. Remove the dial gauge, and the bracket and timing pin of tool 0480066.
20. Check that the 'O' ring is in good condition before re-fitting the plug in the timing connector. Do NOT overtighten the plug.
21. Tighten the injector pipe nuts, while restraining the unions.
22. Remove the flywheel timing pin LDV 104.
23. Refit the timing belt covers and inspection plate.
24. *Refit the intake air duct.*
25. *Connect the battery(s), positive terminal(s) first.*



## FUEL INJECTION PUMP

### Remove and Refit

#### Remove

**Tools required:** 0480054 (18G 1205), 0480066, LDV 103, LDV 104.

*The fuel injection pump can be removed / renewed in situ, but the following operations must be carried out first.*

1. *Disconnect the battery(s), negative (earth) terminal(s) first.*
2. *Detach the intake air duct.*
3. *Disconnect from the injection pump:*
  - *Fuel cut-off solenoid wire.*
  - *Throttle cable.*
  - *Automatic fast idle cable.*
  - *Fuel inlet and spill return pipes. Plug all the connections.*
4. *Remove the timing belt inspection plate and the two belt upper covers.*

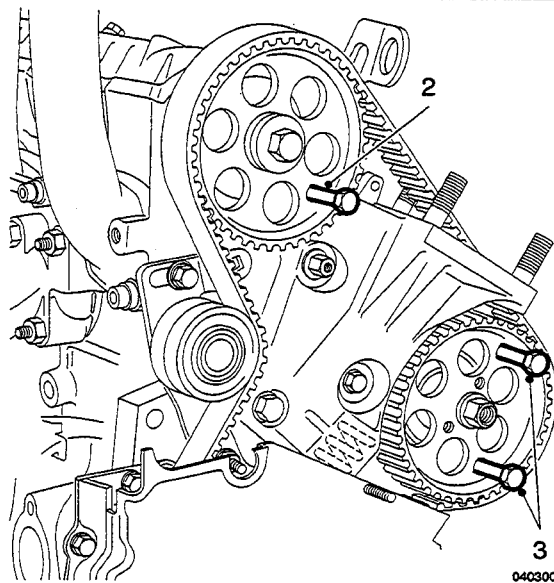
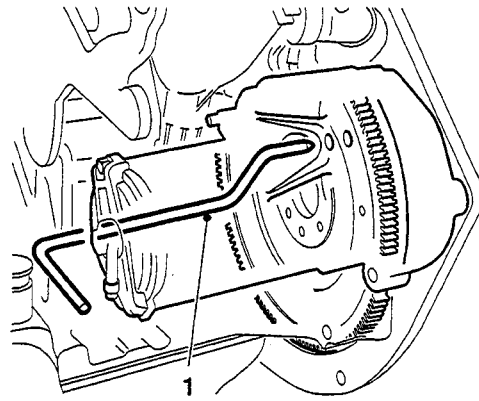

**Fig.1 Fitting timing pin and timing bolts**

1. Flywheel timing pin LDV 104
  2. Camshaft timing bolt
  3. Injection pump timing bolts
5. Turn the crankshaft clockwise until no.4 cylinder (front of engine) is at TDC firing position. Fit the timing pin LDV 104 in the flywheel location. Fit suitable length M8 bolts in the camshaft pulley and fuel injection pump pulley timing holes, finger-tight only.

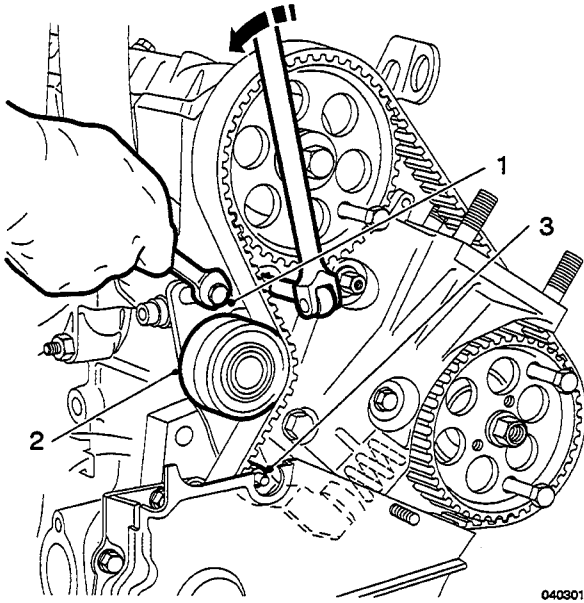

**Fig.2 Releasing timing belt tension**

1. Tensioner securing bolt
2. Tensioner roller
3. Tensioner securing nut

6. Slacken the timing belt tensioner securing nut and bolt.

Release the belt tension by pulling the tensioner roller fully away from the belt against spring pressure, and tighten the securing bolt.

**NOTE:** A square drive hole is provided in the tensioner bracket to facilitate this.

7. Carefully ease the timing belt off the fuel injection pump pulley.
8. Remove the fuel injection pump timing bolts.

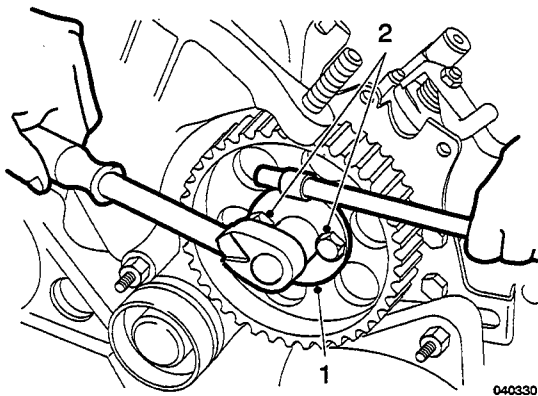

**Fig.3 Removing injection pump pulley**

1. LDV 103
2. Securing bolts

9. Fit tool LDV 103 to the injection pump pulley securing it with the bolts supplied with the tool. Hold the tool with a suitable size bar as illustrated and slacken the pulley securing nut. Continue to turn the nut anti-clockwise to release the pulley from its taper.
10. Remove the pulley, recover the pump drive key and release the tool.

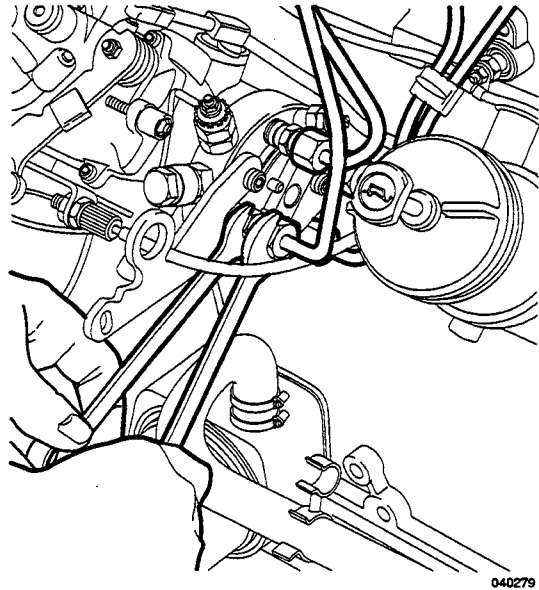

**Fig.4 Slackening fuel injector pipes**

11. Remove the 4 fuel injector pipes, making sure each union is restrained from turning while its nut is slacked. Plug all the connections.
12. Remove the injector pump rear mounting and the 3 flange fixings at the front to release the pump.

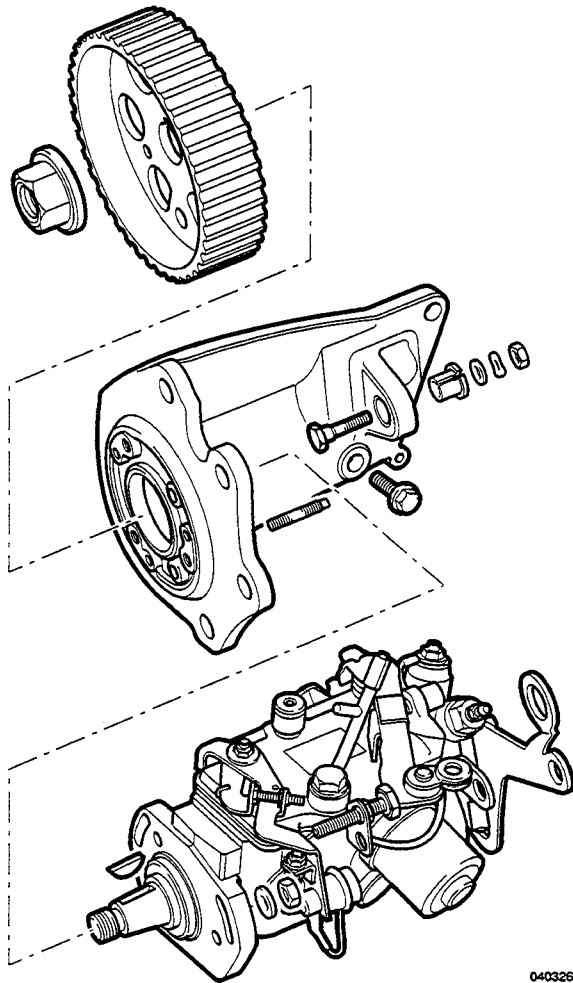
**Refit**

040326

**Fig.5 Injector pump & mountings**

13. Position the injector pump and secure all the mountings finger tight.
14. Fit the injection pump pulley, restraining it with tool 0480054 (18G 1205) or tool LDV 103 to enable the securing nut to be tightened to the correct torque.
15. Turn the injection pump pulley until the timing holes align and fit the timing bolts.
16. Check that the crankshaft remains at TDC, the timing pin LDV 104 is fitted in the flywheel and the camshaft timing bolt is in place. Carefully ease the timing belt over the pulleys, keeping the drive side taut.
17. Remove the camshaft and fuel injection pump timing bolts and the flywheel timing pin LDV 104.

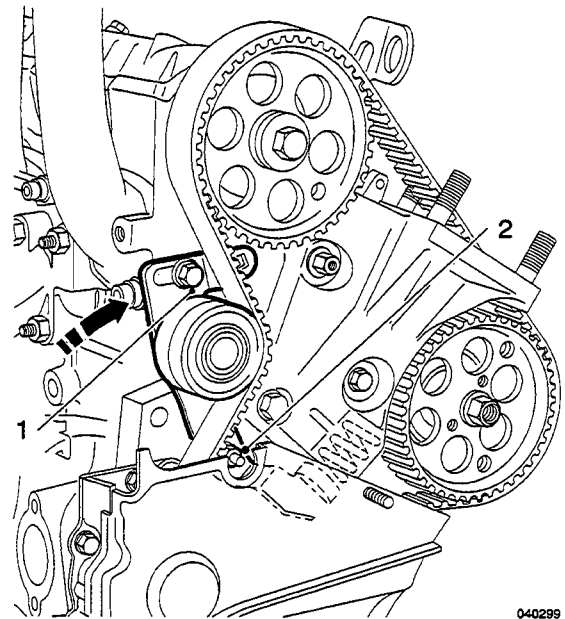

040299

**Fig.6 Adjusting timing belt tension**

1. Tensioner bolt
  2. Tensioner nut
18. Slacken the tensioner securing bolt and nut by two turns, and allow the spring and plunger to self-tension the timing belt. Temporarily tighten the bolt and nut.
  19. Turn the crankshaft clockwise 7 complete turns, then continue turning until the timing pin LDV 104 can be fitted in the flywheel, together with the camshaft and injection pump timing bolts.  
**NOTE:** If it is not possible to fit all the timing pin / bolts, the timing belt fitting procedure has not been carried out correctly and must be repeated.  
**NOTE:** Do not turn the crankshaft anti-clockwise.
  20. Slacken the tensioner nut and bolt by two turns, and allow the spring and plunger to re-tension the timing belt. Then tighten the bolt and the nut to the correct torque.
  21. Remove the camshaft and fuel injection pump timing bolts and flywheel timing pin.
  22. Check / adjust the fuel injection pump timing as described in the section 'Fuel Injection Pump Timing, Check and Adjust'.  
**NOTE:** This requirement only applies at this stage if the timing is being checked statically. If the timing is to be checked dynamically, this is done after starting the engine.

23. Fit the timing belt upper covers and the belt inspection plate.

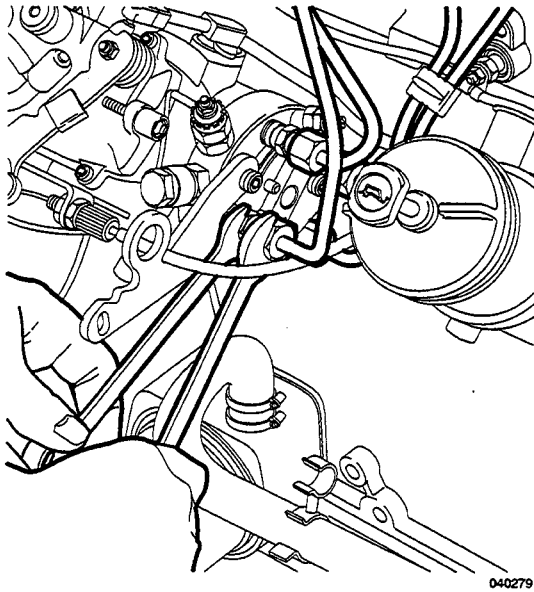

040279

**Fig.7 Tightening fuel injector pipes**

24. If not already fitted, fit the 4 fuel injector pipes, making sure each union is restrained from turning while its nut is tightened.
25. *Connect to the injection pump:*
- *Throttle cable.*
  - *Automatic fast idle cable.*
- Adjust the cables as necessary (see the section 'Fuel Injection Pump Adjustments').*
26. *Connect the fuel inlet and spill return pipes, and the fuel cut-off solenoid wire.*
27. *Connect the intake air duct*
28. *Connect the battery(s), positive terminal(s) first.*
29. *Start the engine, bleeding the system if necessary.*
30. *Check for fuel leaks.*
31. *Check the injection pump timing dynamically.*  
**NOTE:** *If the engine will not start, adjust the position of the fuel injection pump until it does start, then check and re-set the timing dynamically as necessary.*

## INJECTORS

### Remove and Refit

**Tool required:** 0480059 (MS 1501)

#### Remove

1. Disconnect the appropriate injector pipe.
2. Detach the spill return pipes.
3. Remove the injector using tool 0480059 (MS 1501).
4. Extract the domed heat shield washer from the injector aperture; discard it and the copper washer.

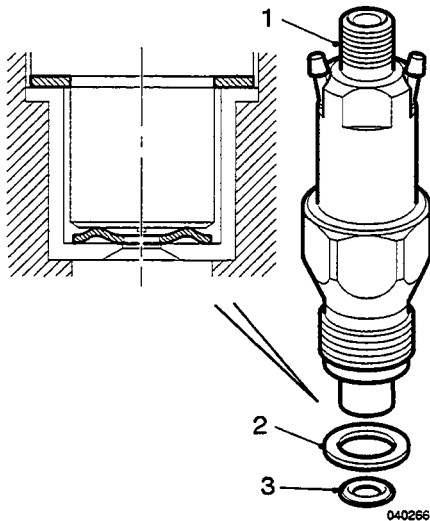

**Fig.1 Injector**

1. Injector
2. Copper washer
3. Heat shield washer

#### Refit

5. Locate a new heat shield washer in the injector aperture with its domed face uppermost
6. Fit the injector with a new copper washer, and tighten to the correct torque using tool 0480059 (MS 1501).
7. Fit the spill return pipes, and re-connect the injector pipe.

8. Start the engine and check for fuel leaks.

### BLEEDING

1. Ensure there is sufficient fuel (at least 1 gallon/4.5 litres) in the fuel tank.
2. Open the bleed screw on the fuel filter outlet banjo bolt.
3. Slowly operate the hand primer button on the filter until air-free fuel flows from the bleed screw.

Tighten the screw.

4. Open the bleed screw on the fuel injection pump. Slowly operate the hand primer again until air-free fuel flows from the bleed screw. Tighten the screw.

5. Do not depress the throttle pedal. Start the engine and check for fuel leaks.

**NOTE:** If the engine does not start after 10 seconds, stop cranking for 5 seconds and repeat the cycle until the engine starts.



# COOLING SYSTEM

COOLING SYSTEM

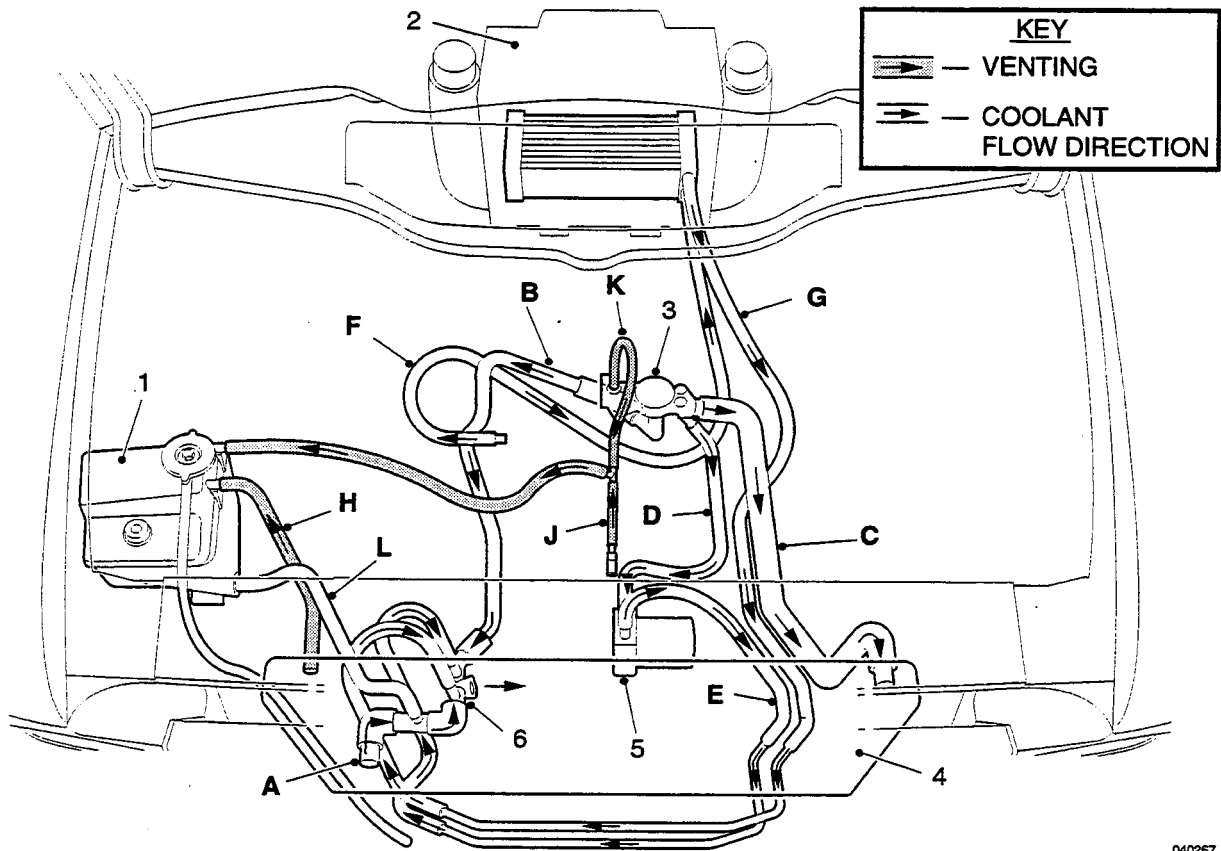

040267

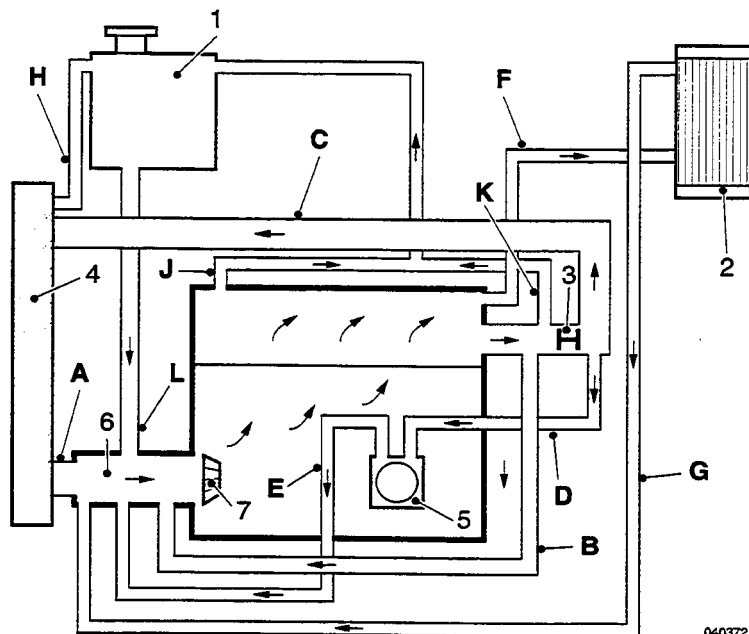

040372

**Fig.1 Cooling system circulation**

- |                   |                      |
|-------------------|----------------------|
| 1. Expansion tank | 4. Radiator          |
| 2. Heater         | 5. Modine oil cooler |
| 3. Thermostat     | 6. Coolant manifold  |
|                   | 7. Water pump        |

## COOLANT CIRCULATION

The water pump (7) draws coolant into the cylinder block from the radiator (4) via the bottom radiator hose 'A' and the coolant manifold (6).

The coolant passes rearwards and upwards into the cylinder head and out to the thermostat (3). When the engine is cold the thermostat will be closed and the hot coolant will return to the coolant manifold via the by-pass hose 'B'.

When the thermostat opens, hot coolant will return to the radiator via the top radiator hose 'C'. Another hose 'D' takes coolant from the thermostat outlet to the Modine oil cooler (5) and returns it to the coolant manifold via hose 'E'.

The heater (2) is supplied with hot coolant from the cylinder head through hose 'F' and returns it to the coolant manifold through hose 'G'.

Other hoses 'H', 'J' and 'K' are for venting air to the expansion tank (1) from the radiator, cylinder head and thermostat housing respectively when filling the system.

The system is filled from the expansion tank via hose 'L'.

## COOLANT DRAIN AND REFILL

To drain:

- **WARNING: USE CAUTION IF THE COOLANT IS HOT.**  
Disconnect the lower radiator hose to the coolant manifold at the radiator.

To re-fill:

- Refit the radiator hose.
- Fill the system through the expansion tank with the correct coolant (50% antifreeze).
- **WARNING: PLACE A THICK CLOTH OVER THE CAP AND EXPANSION TANK BEFORE ATTEMPTING TO REMOVE THE CAP SLOWLY, TO AVOID THE POSSIBILITY OF SCALDING IF THE ENGINE IS HOT.**  
Warm the engine to normal operating temperature and top up as necessary.
- Check the system for leaks.

## COOLING FANS

### Testing

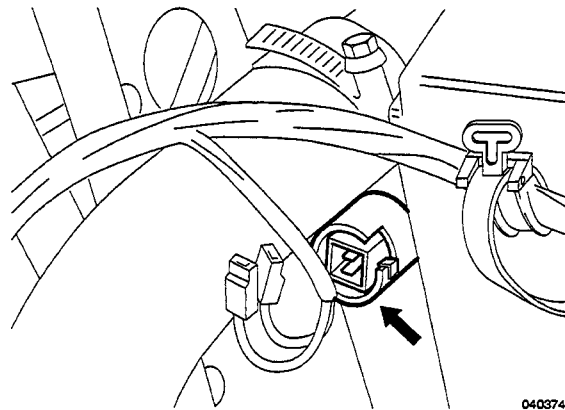

040374

**Fig.1 Cooling fan motor switch**

The electrically operated cooling fans are controlled by a switch located in the radiator. Check the operation of the fans as follows:

1. Disconnect the wires from the switch terminals.
2. Turn the ignition key to position 'II'.  
**WARNING: ENSURE LOOSE CLOTHING AND FINGERS, ETC, WILL NOT FOUL THE ROTATING FANS.**
3. Bridge the terminal wires and the fans will operate. If the fans are inoperative, the cause must be investigated.
4. Return the ignition key to 'O' and re-connect the switch wires.

**COOLING SYSTEM**

## WATER PUMP

The water pump is located in the front of the cylinder block, and is driven by the timing belt.

It can be removed and refitted in situ.

### Remove and Refit

**Tools required:** LDV 102, LDV 104, 0480066.

### Remove

1. **WARNING: USE CAUTION IF THE COOLANT IS HOT.**  
*If working with the engine in situ, it will be necessary to drain coolant from the cylinder block by disconnecting the bottom radiator hose.*
2. Remove the timing belt (see the section 'Timing Belt Remove').

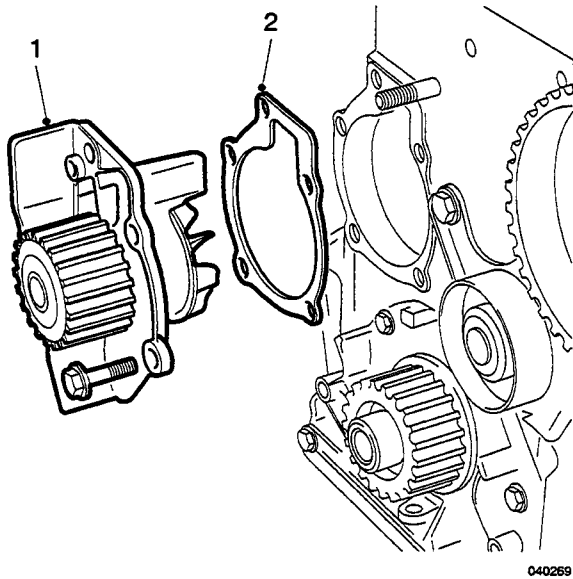

040269

**Fig.1 Water pump**

1. Water pump
2. Gasket

3. Remove the water pump and discard the gasket. Clean off all traces of the old gasket from the cylinder block face.

**Refit**

3. Fit the water pump using a new gasket, and tighten the securing bolts to the correct torque.
4. Refit and tension the timing belt, check the fuel injection pump timing and re-build the engine (see section 'Timing Belt Refit').

*If working with the engine in situ:*

5. Refill with coolant (50% anti-freeze) to the correct level.
6. Re-connect the battery(s), positive terminal(s) first.
7. Start the engine and run until normal operating temperature is reached. Check the coolant level and top up as necessary. **WARNING: PLACE A THICK CLOTH OVER THE CAP AND EXPANSION TANK BEFORE ATTEMPTING TO REMOVE THE CAP SLOWLY, TO AVOID THE POSSIBILITY OF SCALDING IF THE ENGINE IS HOT.**

**THERMOSTAT**  
**Remove and Refit**

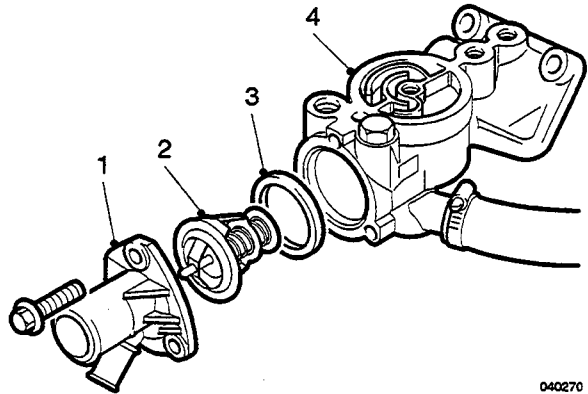

040270

**Fig.1 Thermostat housing**

1. Thermostat cover
2. Thermostat
3. Rubber seal
4. Thermostat housing

1. **WARNING: USE CAUTION IF THE COOLANT IS HOT.**  
*If working with the engine in situ, disconnect the coolant hose at the thermostat housing and allow the coolant to drain.*

2. Remove the 3 bolts securing the thermostat cover.
3. Remove the thermostat and discard the rubber seal.
4. Fit a new seal around the thermostat flange and install the thermostat.
5. Fit the thermostat cover.

*If working with the engine in situ:*

6. Connect the coolant hose to the thermostat outlet.
7. Refill with coolant (50% anti-freeze) to the correct level.
8. Re-connect the battery, positive terminal first.
9. Start the engine and run until normal operating temperature is reached. Check the coolant level and top up as necessary. **WARNING: PLACE A THICK CLOTH OVER THE CAP AND EXPANSION TANK BEFORE ATTEMPTING TO REMOVE THE CAP SLOWLY, TO AVOID THE POSSIBILITY OF SCALDING IF THE ENGINE IS HOT.**



## HEATER PLUG SYSTEM

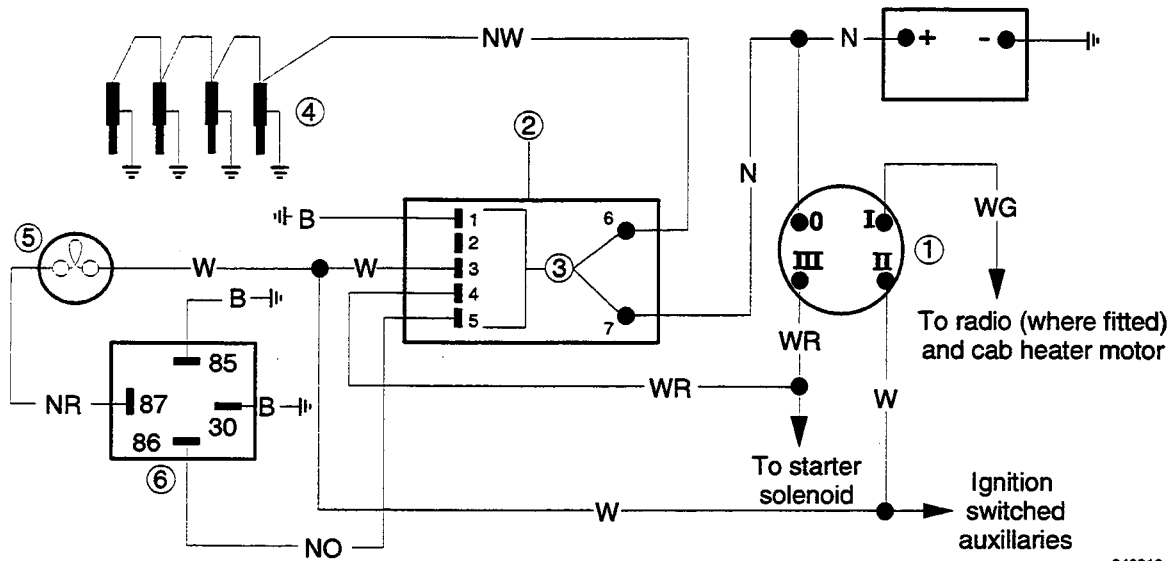

040310

Fig.1 Heater plug circuit

1. Ignition switch
2. Heater plug controller
3. Heater plug controller (Terminal numbers)
4. Heater plugs
5. Heater plug warning light
6. Warning light relay

### Wiring colour code

B	Black
N	Brown
NR	Brown / red
NW	Brown / white
NO	Brown / orange
W	White
WG	White / green
WR	White / red

### SYSTEM COMPONENTS

#### Heater Plugs

The sheathed element of the heater plug projects into the swirl chamber area of the engine cylinder head. The purpose of the heater plug is to assist in heating the air inside the swirl chamber to a high enough temperature during pre-heat and cranking in order that fuel will burn when injected. This ensures easy cold starting.

The temperature of the plug tip reaches approximately 850° C during operation.

#### Heater Plug Controller

Secured to the left hand side bulkhead inside the engine compartment, the controller is a sealed, non-serviceable unit. The controller comprises an integrated circuit and relay which switches the heater plugs on and off.

The circuit also operates the warning light via the warning light relay.



## SYSTEM OPERATION

### The Ignition Switch

Functions are as follows:

#### Position 0

Ignition switch off – steering locked – no electrical output.

#### Position I (Auxiliary)

Steering not locked – radio (if fitted) and cab heater motor supplied from white/ green wire.

#### Position II (Ignition on)

Steering not locked – radio (if fitted) and cab heater motor supplied as before – heater plug controller energised – heater plugs energised to give pre-heating – heater plug warning light on. After approximately 8 seconds pre-heat (at 0° C ambient air temperature) heater plug warning light goes out – engine can now be started (see position III).

The pre-heat period becomes shorter as ambient air temperature increases.

If an attempt is made to start the engine before the heater plug warning light goes out, the engine cranking period will be extended and the engine will prove difficult to start.

If the engine is not cranked after the heater plug warning light goes out, the heater plugs remain switched on for a further period of approximately 7 seconds. Therefore if the ignition is switched on but the engine not cranked, the heater plugs will be switched on only for the time the warning light is on plus approximately 7 seconds.

This prevents unnecessary battery discharge and prolongs heater plug life.

#### Position III (Engine cranking)

Steering not locked – radio (if fitted) and cab heater motor not supplied.

After the heater plug warning light goes out, engine can be started without using the accelerator (the fuel injection pump has an automatic excess fuel device which operates during cranking, and an automatic cold engine fast idle control).

At all times when the starter motor is cranking the engine, the heater plugs are energised to assist starting.

Once the engine has been cranked on the starter, the heater plugs are then switched off. If the engine has failed to start, the starting procedure must be repeated.

This system does not give any post-heat after the starter motor has cranked the engine. The automatic cold engine fast idle control will keep the engine running smoothly during the warm-up period.

## HEATER PLUG TESTING

**Tool required:** 1210515 (DX 900)

Remove the heater plugs and test using tool 1210515 (DX 900) as follows:

1. Place heater plug into the clamp at the end of the tester.
2. Connect tester leads as follows:
  - Red lead to battery positive
  - Black lead to battery negative
  - Yellow lead to heater plug centre terminal
3. **WARNING: AFTER TESTING, HEATER PLUGS WILL BE HOT. DO NOT HANDLE, USE PLIERS OR SIMILAR TO REMOVE FROM TESTER. LEAVE IN A SAFE PLACE UNTIL SUFFICIENTLY COOL TO HANDLE.** Depress the 'TEST' button; note the initial current draw and how long the current takes to stabilise, by observing the LED's which illuminate at 5 second intervals. Also note whether the heater plug glows at the tip first; if it does not, it must be renewed.
4. Compare the results with the information in 'Data'.
5. Repeat and record results on all the heater plugs. Replace any which prove defective.
6. Refit serviceable / new heater plugs (smear the threads with PBC grease), and tighten to the correct torque.

Part Number **DW 03934002**