



WESTERN STAR®



Driver's Manual

Introduction

This manual provides information needed to operate and understand the vehicle and its components. More detailed information is contained in the *Owner's Warranty Information for North America* booklet and in the vehicle's workshop and maintenance manuals.

Custom-built Western Star vehicles are equipped with various chassis and cab components. Not all of the information contained in this manual applies to every vehicle. For details about components in your vehicle, refer to the chassis specification pages included in all new vehicles and to the vehicle specification decal located inside the vehicle.

For your reference, keep this manual in the vehicle at all times.

IMPORTANT: Descriptions and specifications in this manual were in effect at the time of printing. Western Star Trucks reserves the right to discontinue models and to change specifications or design at any time without notice and without incurring obligation. Descriptions and specifications contained in this publication provide no warranty, expressed or implied, and are subject to revisions and editions without notice.

Environmental Concerns and Recommendations

Whenever you see instructions in this manual to discard materials, you should first attempt to reclaim and recycle them. To preserve our environment, follow appropriate environmental rules and regulations when disposing of materials.

Event Data Recorder

This vehicle is equipped with one or more devices that record specific vehicle data. The type and amount of data recorded varies depending on how the vehicle is equipped (such as the brand of engine, if an air bag is installed, or if the vehicle features a collision avoidance system, etc.).

This vehicle is equipped with an event data recorder (EDR). The main purpose of an EDR is to record data in certain crash or near-crash situations, such as air bag deployment or hitting a road obstacle, that will assist in understanding how a vehicle's systems

performed. The EDR is designed to record data related to vehicle dynamics and safety systems for approximately 60 seconds. This data can help provide a better understanding of the circumstances in which crashes and injuries occur. Data recorded includes the following items:

- how various systems in the vehicle were operating
- engine system information
- how far (if at all) the driver was depressing the accelerator
- if the driver was depressing the brake pedal
- how fast the vehicle was traveling

NOTE: Data is not recorded by the EDR under normal driving conditions. Personal data such as name, gender, age, and crash location are not recorded. However, other parties such as law enforcement could combine the EDR data with the type of personally identifying data routinely acquired during a crash investigation.

To read data recorded by an EDR, special equipment is required, and access to the vehicle or the EDR is needed. In addition to the vehicle manufacturer, other parties that have the special equipment, such as law enforcement, can read the information if they have access to the vehicle or the EDR.

Emissions and Fuel Efficiency Compliance

This vehicle must be regularly inspected and maintained as indicated in the *Western Star Maintenance Manual*, and in the *Pre- and Post-Trip Inspections and Maintenance* chapter in this manual, in order to continue satisfactory performance and ensure coverage of the vehicle under the manufacturer's warranty. Many maintenance procedures ensure that the vehicle and engine continue to comply with applicable emissions standards. Maintenance procedures, using components engineered to comply with greenhouse gas emissions and fuel efficiency regulations, may be performed by an authorized Daimler Trucks North America dealer, an independent outlet, or the vehicle owner or operator.

The vehicle owner is responsible for determining the suitability of replacement components to maintain

Foreword

compliance with federal and local jurisdictional regulations. Components including, but not limited to, tires, cab/sleeper side extenders, chassis fairings, bumper, hood, vehicle speed limiters, and idle reduction timers are specifically designed and manufactured to exacting standards for regulatory fuel efficiency and greenhouse gas emissions compliance. It is important that these components are always replaced with components that meet or exceed the performance of the originally installed components.

Place de Ville Tower C, 330 Sparks Street, Ottawa, Ontario, Canada K1A 0N5.

For additional road safety information, please visit the Road Safety website at: www.tc.gc.ca/roadsafety.

Customer Assistance Center

Having trouble finding service? For over-the-road breakdown assistance, customer concerns, literature requests, and the location of the nearest dealer, call 1-866-850-STAR (7827). Call night or day, weekdays or weekends. Our people are knowledgeable, professional, and committed to following through to help you keep your truck moving.

Reporting Safety Defects

If you believe that your vehicle has a defect which could cause a crash or could cause injury or death, you should immediately inform the National Highway Traffic Safety Administration (NHTSA) in addition to notifying Western Star Trucks.

If the NHTSA receives similar complaints, it may open an investigation, and if it finds that a safety defect exists in a group of vehicles, it may order a recall and remedy campaign. However, NHTSA cannot become involved in individual problems between you, your dealer, or Western Star Trucks.

To contact NHTSA, you may call the Vehicle Safety Hotline toll-free at 1-888-327-4236 (TTY: 1-800-424-9153); go to www.safercar.gov; or write to: Administrator, NHTSA, 1200 New Jersey Avenue, SE, Washington, DC 20590. You can also obtain other information about motor vehicle safety from www.safercar.gov.

Canadian customers who wish to report a safety-related defect to Transport Canada, Defect Investigations and Recalls, may telephone the toll-free hotline 1-800-333-0510, or contact Transport Canada by mail at: Transport Canada, ASFAD,

© 2001–2015 Daimler Trucks North America LLC. All rights reserved. Daimler Trucks North America LLC is a Daimler company.

No part of this publication, in whole or part, may be translated, reproduced, stored in a retrieval system, or transmitted in any form by any means, electronic, mechanical, photocopying, recording, or otherwise, without the prior written permission of Daimler Trucks North America LLC. For additional information, please contact Daimler Trucks North America LLC, Service Systems and Documentation, P.O. Box 3849, Portland OR 97208–3849 U.S.A. or refer to www.Daimler-TrucksNorthAmerica.com and www.WesternStarTrucks.com.

Contents

Chapter		Page
	Introduction, Environmental Concerns and Recommendations, Event Data Recorder, Emissions and Fuel Efficiency Compliance, Customer Assistance Center, Reporting Safety Defects	Foreword
1	Vehicle Identification	1.1
2	Vehicle Access	2.1
3	Instruments	3.1
4	Driver Controls	4.1
5	Climate Controls	5.1
6	Seats and Restraints	6.1
7	Cab and Sleeper Features	7.1
8	Electrical System	8.1
9	Engine Starting, Operation, and Shutdown	9.1
10	Optional Engine Systems	10.1
11	Emissions and Fuel Efficiency	11.1
12	Brake Systems	12.1
13	Steering System	13.1
14	Manual Transmissions and Clutch	14.1
15	Automated and Automatic Transmissions	15.1
16	Drive Axles	16.1
17	Fifth Wheels	17.1
18	Trailer Couplings	18.1
19	Headlight Aiming	19.1
20	Vehicle Appearance and Care	20.1
21	In An Emergency	21.1
22	Pre- and Post-Trip Checklists	22.1
23	Pre- and Post-Trip Inspections and Maintenance	23.1
	Index	I.1

Vehicle Identification

Component Information Label	1.1
Federal Motor Vehicle Safety Standard Labels	1.1
Canadian Motor Vehicle Safety Standard Labels	1.1
Component GWR Label	1.1
Emissions Labels	1.2

Vehicle Identification

Component Information Label

NOTE: Labels shown in this chapter are examples only. Actual specifications may vary from vehicle to vehicle.

The component information label lists the vehicle model, identification number, and major component models. It also lists the major assemblies and installations shown on the chassis specification sheet. One copy of the component information label is attached to the inside of the glove box; another copy is inside the rear cover of the *Owner's Warranty Information for North America* booklet. An illustration of the label is shown in [Fig. 1.1](#).

Western Star Trucks		COMPONENT INFORMATION		USE VEHICLE ID NUMBER WHEN ORDERING PARTS.	
MANUFACTURED BY	PRELIGHTLINER LTD				
VEHICLE ID NO	012345678901234567890123456789012345678901				
MODEL	X 11 CHAR X	BASE MODEL	XX 12 CHAR X	DATE OF MFR	XX 13 CHAR XX
VEHICLE ID NO	X 17 CHARACTERS X	CUSTOMER	6 CHAR	WHEELBASE	XX 13 CHAR XX
ENGINE NO	01234567890123456789012345678901	ENGINE NO	0123456789012345678901	TRANE NO	0123456789012345678901
MAIN TRANE NO	01234567890123456789012345678901	TRANE NO	0123456789012345678901	FRSE PUMP NO	0123456789012345678901
FRSE PUMP NO	01234567890123456789012345678901	FRSE PUMP NO	0123456789012345678901	FRONT AXLE NO	0123456789012345678901
FRONT AXLE NO	01234567890123456789012345678901	FRONT AXLE NO	0123456789012345678901	1ST INT AXLE NO	0123456789012345678901
1ST INT AXLE NO	01234567890123456789012345678901	1ST INT AXLE NO	0123456789012345678901	2ND INT AXLE NO	0123456789012345678901
2ND INT AXLE NO	01234567890123456789012345678901	2ND INT AXLE NO	0123456789012345678901	3RD INT AXLE NO	0123456789012345678901
3RD INT AXLE NO	01234567890123456789012345678901	3RD INT AXLE NO	0123456789012345678901	4TH INT AXLE NO	0123456789012345678901
4TH INT AXLE NO	01234567890123456789012345678901	4TH INT AXLE NO	0123456789012345678901	5TH INT AXLE NO	0123456789012345678901
5TH INT AXLE NO	01234567890123456789012345678901	5TH INT AXLE NO	0123456789012345678901	6TH INT AXLE NO	0123456789012345678901
6TH INT AXLE NO	01234567890123456789012345678901	6TH INT AXLE NO	0123456789012345678901	REAR AXLE NO	0123456789012345678901
REAR AXLE NO	01234567890123456789012345678901	REAR AXLE NO	0123456789012345678901	RAI10	0123456789012345678901
PALNT MFR	01234567890123456789012345678901	PALNT MFR	0123456789012345678901	FOR COMPLETE PAINT INFORMATION SEE VEHICLE SPECIFICATION SHEET.	
PAINT NUMBER	01234567890123456789012345678901	PAINT NUMBER	0123456789012345678901	PART NO. 24-01214-010 REV C	
06/28/2011		f080173			

Fig. 1.1, Component Information Label

Federal Motor Vehicle Safety Standard Labels

NOTE: Due to the variety of Federal Motor Vehicle Safety Standard (FMVSS) certification requirements, not all of the labels shown will apply to your vehicle.

The FMVSS labels are attached to the driver-side door frame B-pillar, as shown in [Fig. 1.2](#). Tractors with or without fifth wheels purchased in the U.S. are certified by means of a certification label. See [Fig. 1.3](#).

Trucks built without a cargo body that are intended for service in the U.S. have an incomplete vehicle certification label attached by the final-stage manufacturer. See [Fig. 1.4](#). This label will be attached to the incomplete vehicle document included with the vehicle, and certifies that the vehicle conforms to all applicable FMVSS regulations in effect on the date of completion.

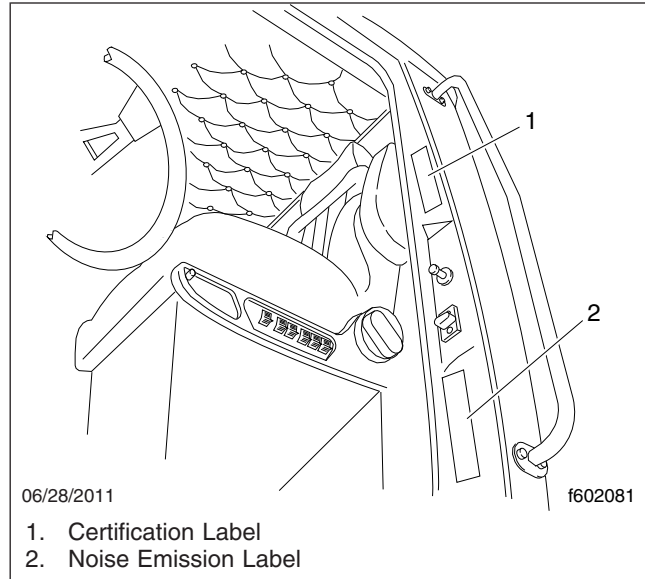

Fig. 1.2, Label Locations

Canadian Motor Vehicle Safety Standard Labels

In Canada, tractors with fifth wheels are certified by means of a statement of compliance label with the Canadian National Safety Mark attached to the driver-side door frame B-pillar. See [Fig. 1.5](#).

Trucks built without a cargo body and tractors built without a fifth wheel that are intended for service in Canada have an incomplete vehicle certification label (similar to [Fig. 1.4](#)) attached to the driver-side B-pillar. After completion of the vehicle, a complete certification label must be attached by the final-stage manufacturer to certify that the vehicle conforms to all applicable Canada Motor Vehicle Safety Standard (CMVSS) regulations in effect on the date of completion.

Component GWR Label

The component GWR label is located on the A-pillar of the driver-side door frame. The label provides maximum GWR ratings for each component.

See [Fig. 1.6](#) for a typical component GWR label.

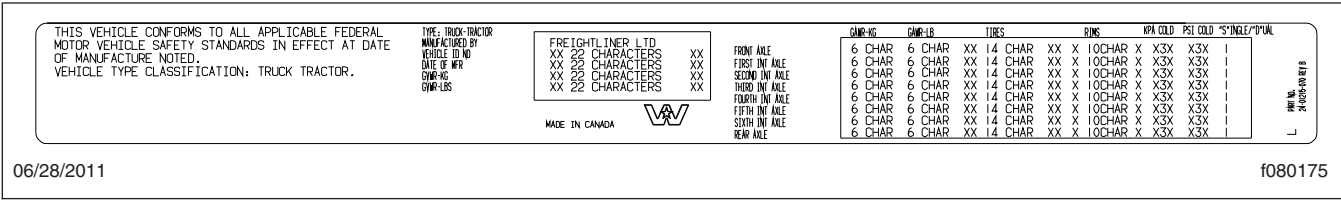

Fig. 1.3, Vehicle Certification Label

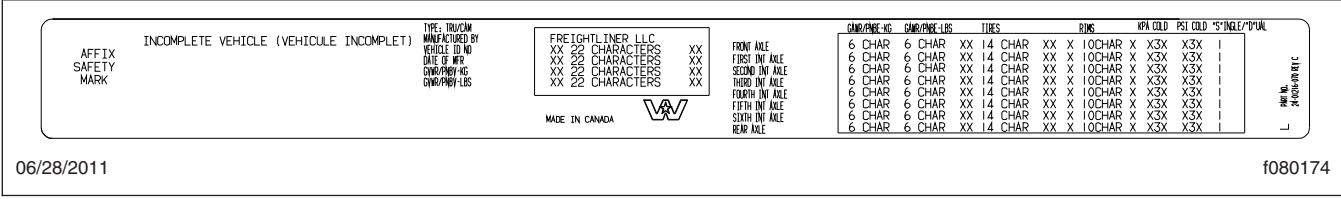

Fig. 1.4, Incomplete Vehicle Certification Label



Fig. 1.5, Canadian National Safety Mark

Emissions Labels

Aftertreatment System Indicators Label

Engines and vehicles manufactured after December 31, 2006 and domiciled in the U.S. or Canada are required to meet all EPA regulations effective as of the vehicle build date, and are equipped with an emission aftertreatment system (ATS). Vehicles domiciled outside of the U.S. and Canada may not have aftertreatment equipment, depending upon local statutory emissions guidelines. See [Table 1.1](#).

A warning label on the driver-side visor contains important warning indicators in the instrument cluster that pertain to the ATS. See [Fig. 1.7](#) or [Fig. 1.8](#).

It is a violation of U.S. federal law to alter exhaust plumbing, ATS, or other components in any way that would bring the engine/vehicle out of compliance with certification requirements [Ref: 42 U.S.C. S7522(a)

(3)]. It is the owner’s responsibility to maintain the vehicle so that it conforms to EPA regulations.

EPA Noise Emission Control Label

A vehicle noise emission control label ([Fig. 1.9](#)) is located on the driver-side B-pillar as shown in [Fig. 1.2](#). It is the owner’s responsibility to maintain the vehicle so that it conforms to EPA regulations.

IMPORTANT: Certain Western Star incomplete vehicles may be produced with incomplete noise control hardware. Such vehicles will not have a vehicle noise emission control information label. For such vehicles, it is the final-stage manufacturer’s responsibility to complete the vehicle in conformity to U.S. EPA regulations (40 CFR Part 205) and label it for compliance.

Vehicle Emission Control Information Label

Model year 2013 and later vehicles meet additional requirements as specified by federal greenhouse gas and fuel efficiency regulations (GHG14). These vehicles are equipped with components that increase fuel efficiency and reduce GHG emissions. Components may include, but are not limited to, low rolling resistance tires; aerodynamic devices such as hood, cab side extenders, and fuel tank fairings; vehicle speed limiters; and idle shutdown timers.

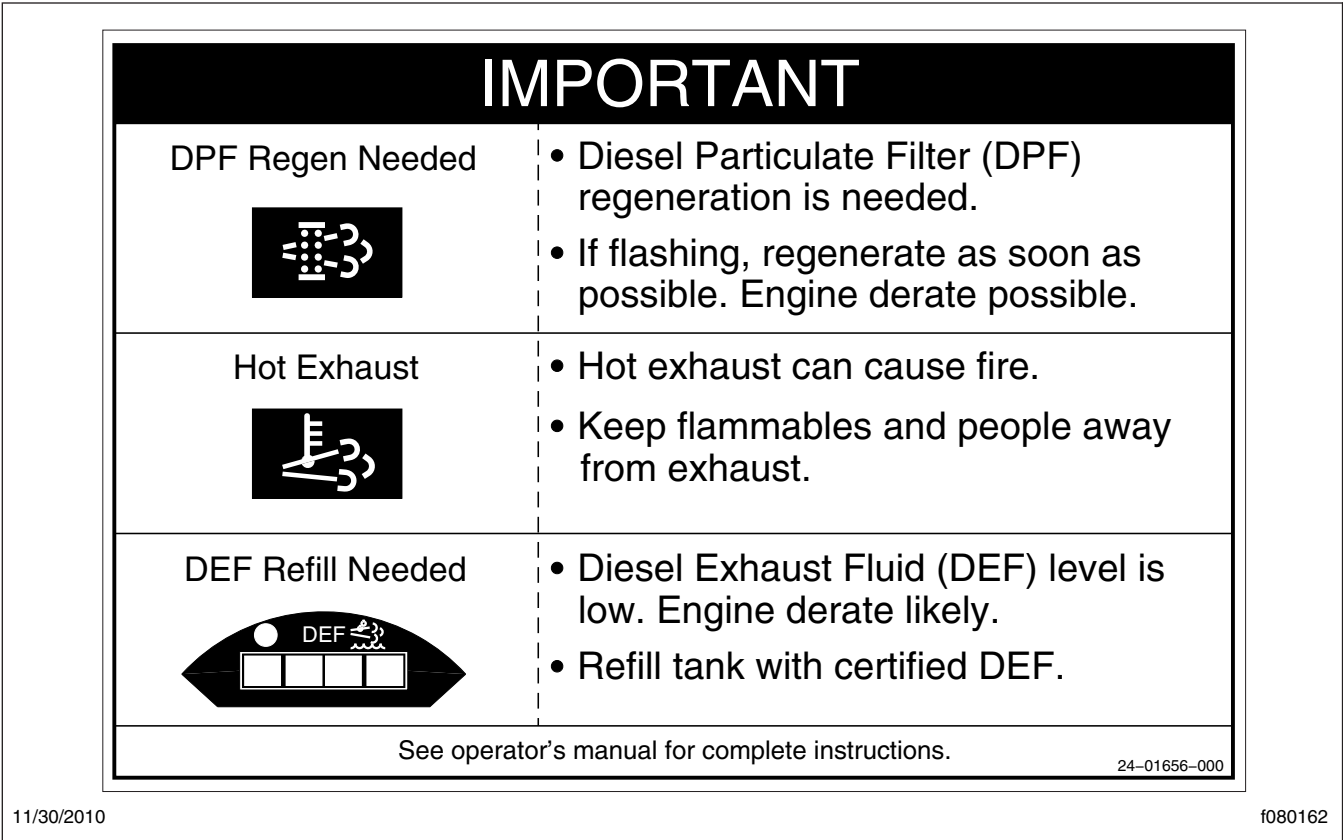

Fig. 1.8, ATS Indicators, EPA10 and Newer

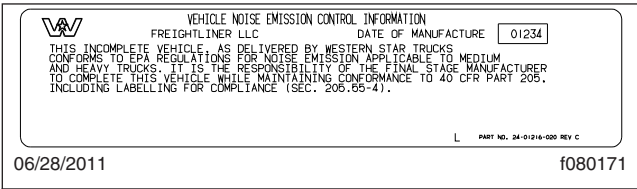

Fig. 1.9, Vehicle Noise Emission Control Label

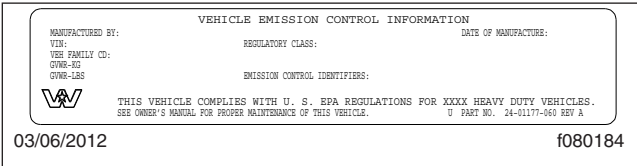

Fig. 1.10, Vehicle Emission Control Information Label

A Vehicle Emission Control Information Label is located on the driver-side door. See [Fig. 1.10](#). It is the owner's responsibility to maintain the vehicle so that it conforms to EPA and NHTSA regulations.

Certified Clean Idle Label

The California Air Resources Board (CARB) requires model year 2008 and newer heavy-duty diesel engines to be equipped with a non-programmable engine shutdown system that automatically shuts down the engine after five minutes of idling in order to limit emissions of particulate matter and NOx.

Certified vehicles are equipped with a label placed near the bottom edge of the driver-side door. See [Fig. 1.11](#).

Vehicle Identification



Fig. 1.11, CARB Clean Idle Label

2

Vehicle Access

Door Locks and Handles	2.1
Grab Handles and Access Steps	2.2
Back-of-Cab Access	2.5
Hood Opening and Closing	2.7

Vehicle Access

Door Locks and Handles

To unlock either door from outside the cab, insert the key in the lock and turn it one-quarter turn towards the front of the vehicle. See [Fig. 2.1](#). Turn the key back to the original position to remove it. Pull out on the paddle latch to open the door.

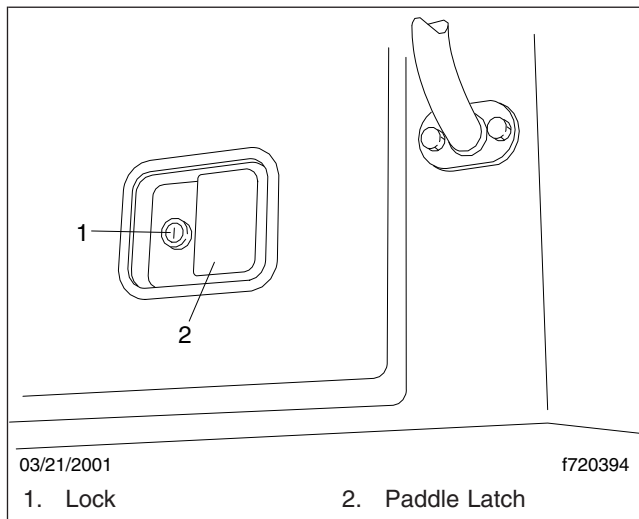

Fig. 2.1, Exterior Door Handle

To lock either door from outside the cab, insert the key in the lock and turn it one-quarter turn towards the rear of the vehicle. Turn the key back to the original position to remove it. If the door is closed, it will now be locked. If the door is open, close the door firmly.

To lock either door from inside the cab, push the lock button down. Pull the lock button up to unlock the door from the inside.

To open either door from inside the cab, pull the lock button up, then pull the interior door latch out and push the door outwards.

Remote Keyless Entry

Remote keyless entry is optional on Western Star vehicles. The remote entry key fob can be used to unlock the doors from outside the cab.

To unlock both doors, press the unlock button. To lock both doors, press the lock button. See [Fig. 2.2](#).

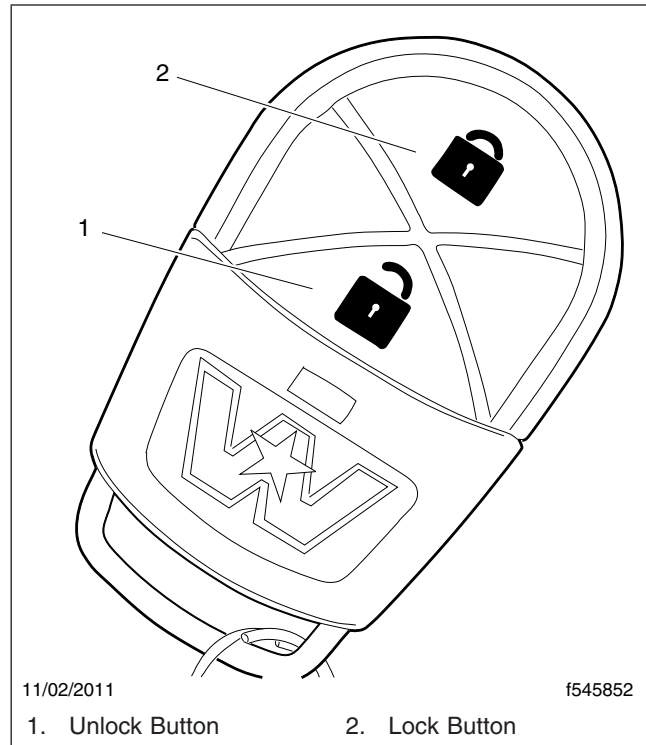

Fig. 2.2, Key Fob

Key Fob Programming

A maximum of four fobs can be programmed to work on one vehicle. Whenever a new fob will be used, all existing fobs must be reprogrammed at the same time. Any existing fobs that were previously programmed will no longer work on the vehicle unless they are all reprogrammed at the same time.

1. Remove the passenger-side electrical access panel, located next to the glove box. See [Fig. 2.3](#).
2. Locate the 2-wire connector in the area between the auxiliary and main power distribution modules (PDMs) with circuit 443* and ground.

NOTE: If the 2-wire connector cannot be located, the connector may be hanging below the PDM. In this case, remove the heater cover panel, which is located below the fuse panel.

3. Use a short length of wire or a paperclip to short the two terminals together three times within five seconds.
4. Wait three seconds.

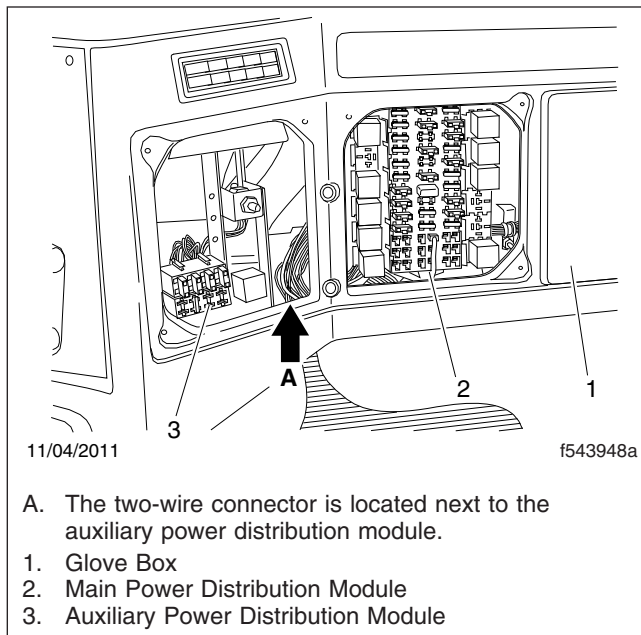

Fig. 2.3, Passenger-Side Electrical Access Panel (removed)

5. Press and hold the first fob's lock button for two seconds. The LED in the fob will flash while the button is held.
6. Press the lock button on the second fob for one second. The LED in the fob will flash while the button is held.
7. Repeat step 6 for any additional fobs.

NOTE: The system will exit program mode after one minute of no activity.

Grab Handles and Access Steps

The grab handles, access steps, and steering wheel are all part of the cab access system. Use these "helping hands" when getting into or out of the cab. They will increase your security and comfort.

CAUTION

Slipping or falling from the vehicle can result in personal injury or property damage.

Wet or dirty shoes greatly increase the chance of slipping or falling. If your shoes are wet or dirty,

be especially careful when entering or exiting the vehicle.

Always maintain three-point contact with the vehicle when entering or exiting the cab. Three-point contact means both feet and one hand, or both hands and one foot.

When steps are mounted on battery box covers, make sure that the cover is latched and secure before using the steps.

Do not step on the fuel tank, battery box, frame, etc. unless adequate slip resistant surfaces and handholds are provided.

Do not jump from the vehicle.

For ease of entry and exit, there are multiple grab handles: a handle on the A-pillar (optional on the driver's side), handles on the inside of the door, and sidewall grab handles. In addition, the steering wheel may be used to provide a secure handhold. There are at least two access steps to provide secure footholds.

IMPORTANT: Vehicles built before November 7, 2011 have lower door grab handles on the inside of each door. Vehicles built on or after November 7, 2011 have lower pockets on the inside of each door, which may be used as a secure handhold.

Entering the Driver's Side

1. Open the driver-side door and place anything that you are carrying in the cab.
2. Grasp the sidewall grab handle with your right hand. See [Fig. 2.4](#) or [Fig. 2.5](#).
3. Grasp the lower door pocket or grab handle with your left hand.
4. Place your right foot on the bottom step, and pull yourself up.
5. Place your left foot on the top step.
6. Grasp the steering wheel or A-pillar grab handle, if equipped, with your left hand.
7. Step into the cab with your right foot first, and grasp the steering wheel with your right hand.

Vehicle Access

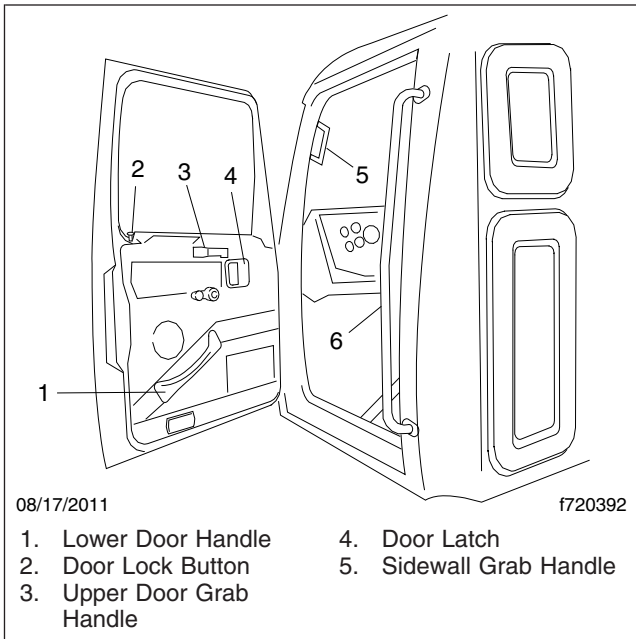

Fig. 2.4, Driver-Side Cab Access (vehicles built before November 7, 2011)

Exiting the Driver's Side

IMPORTANT: Do not attempt to exit the cab while carrying any items in your hands. Place them in an accessible location on the seat or cab floor and make sure they will not get in your way as you exit, then retrieve them after you have exited the cab.

CAUTION

Always face in when exiting the cab. Do not attempt to exit with your back to the cab, as you would be going down a flight of stairs. It is easier to slip or lose your balance. If you slip when exiting in this way, there is a greater likelihood of personal injury.

1. Grasp the steering wheel with both hands, place your left foot on the top step, and stand on the threshold, facing into the cab.
2. Grasp the sidewall grab handle with your right hand. See [Fig. 2.4](#) or [Fig. 2.5](#).
3. Move your right foot to the bottom step.

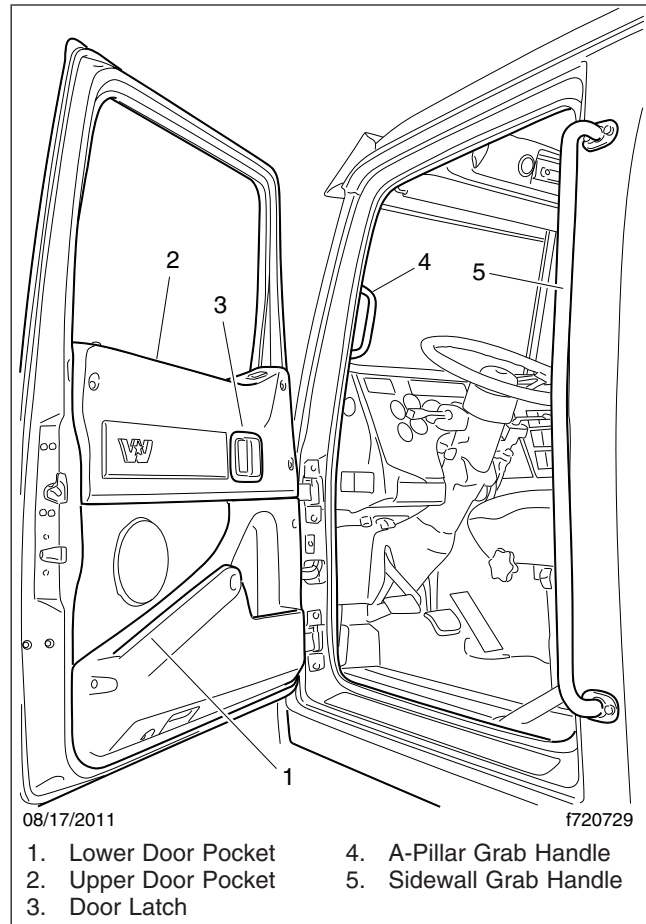

Fig. 2.5, Driver-Side Cab Access (vehicles built November 7, 2011 and later)

4. Move your left hand to the lower door pocket or grab handle.
5. Step to the ground with your left foot first.

Entering the Passenger's Side

1. Open the passenger-side door and place anything that you are carrying in the cab.
2. Grasp the sidewall grab handle with your left hand. See [Fig. 2.6](#) or [Fig. 2.7](#).
3. Grasp the lower door pocket or grab handle with your right hand.
4. Place your left foot on the bottom step.
5. Place your right foot on the top step and move your right hand to the A-pillar grab handle.

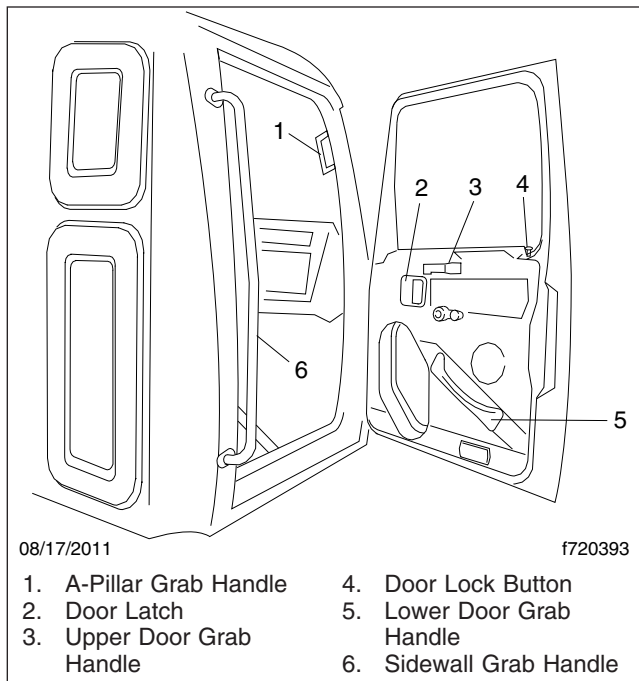

Fig. 2.6, Passenger-Side Cab Access (vehicles built before November 7, 2011)

6. Place your left foot on the top step, then move your left hand to the A-pillar grab handle.
7. Step into the cab with your left foot first.

Exiting the Passenger's Side

IMPORTANT: Do not attempt to exit the cab while carrying any items in your hands. Place them in an accessible location on the seat or cab floor and make sure they will not get in your way as you exit, then retrieve them after you have exited the cab.

CAUTION

Always face in when exiting the cab. Do not attempt to exit with your back to the cab, as you would going down a flight of stairs. It is easier to slip or lose your balance. If you slip when exiting in this way, there is a greater likelihood of personal injury.

1. Grasp the A-pillar grab handle with both hands, then place your right foot on the top step while facing inward. See [Fig. 2.6](#) or [Fig. 2.7](#).

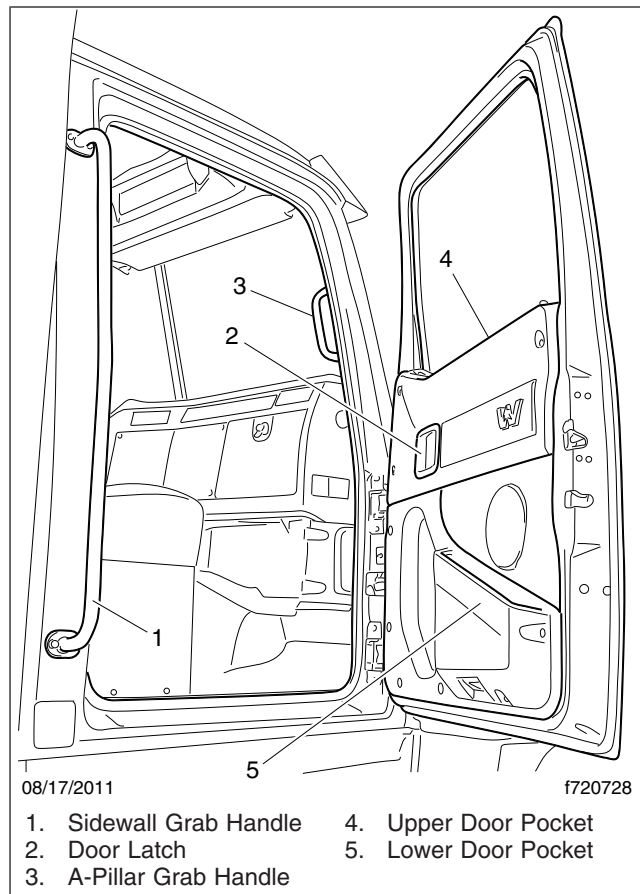

Fig. 2.7, Passenger-Side Cab Access (vehicles built November 7, 2011 and later)

2. Place your left foot on the top step.
3. Move your left hand to the sidewall grab handle.
4. Move your right foot to the bottom step.
5. Move your right hand to the lower door pocket or grab handle.
6. Step to the ground with your left foot first.

Entering the Driver's Side, Right-Hand-Drive Vehicles

1. Open the driver-side door, and place anything that you are carrying in the cab.
2. Grasp the sidewall grab handle with your left hand.

Vehicle Access

3. Grasp the lower door pocket or grab handle with your right hand.
4. Place your left foot on the bottom step.
5. Place your right foot on the top step.
6. Move your right hand to the steering wheel or A-pillar grab handle, if equipped.
7. Step into the cab with your left foot first, and grasp the steering wheel with your left hand.

Exiting the Driver's Side, Right-Hand-Drive Vehicles

IMPORTANT: Do not attempt to exit the cab while carrying any items in your hands. Place them in an accessible location on the seat or cab floor and make sure they will not get in your way as you exit, then retrieve them after you have exited the cab.



Always face in when exiting the cab. Do not attempt to exit with your back to the cab, as you would going down a flight of stairs. It is easier to slip or lose your balance. If you slip when exiting in this way, there is a greater likelihood of personal injury.

1. Grasp the steering wheel with both hands, place your right foot on the top step, and stand on the threshold, facing into the cab.
2. Grasp the sidewall grab handle with your left hand.
3. Move your left foot to the bottom step.
4. Move your right hand to the lower door pocket or grab handle.
5. Step to the ground with your right foot first.

Entering the Passenger's Side, Right-Hand-Drive Vehicles

1. Open the passenger-side door and place anything that you are carrying in the cab.
2. Grasp the sidewall grab handle with your right hand.

3. Grasp the lower door pocket or grab handle with your left hand.
4. Place your right foot on the bottom step.
5. Place your left foot on the top step and move your left hand to the A-pillar grab handle.
6. Place your right foot on the top step, then move your right hand to the A-pillar grab handle.
7. Step into the cab with your right foot first.

Exiting the Passenger's Side, Right-Hand-Drive Vehicles

IMPORTANT: Do not attempt to exit the cab while carrying any items in your hands. Place them in an accessible location on the seat or cab floor and make sure they will not get in your way as you exit, then retrieve them after you have exited the cab.



Always face in when exiting the cab. Do not attempt to exit with your back to the cab, as you would going down a flight of stairs. It is easier to slip or lose your balance. If you slip when exiting in this way, there is a greater likelihood of personal injury.

1. Grasp the A-pillar grab handle with both hands, then place your left foot on the top step while standing up from the seat facing inward.
2. Place your right foot on the top step.
3. Move your right hand to the sidewall grab handle.
4. Move your right foot to the bottom step.
5. Move your left hand to the lower door pocket or grab handle.
6. Step to the ground with your left foot first.

Back-of-Cab Access

When trailer air and electrical connections cannot be reached conveniently from the ground, Federal Motor Carrier Safety Regulations require that tractors have adequate back-of-cab access. Grab handles are typically located on the backwall of the cab or sleeper, or on the inside of the cab extender, if equipped. See

Fig. 2.8. A grab handle may also be provided on the exhaust stack. Steps may be mounted on the fuel tank(s), battery or tool box(es), or on metal brackets secured to the frame rail. A deck plate is mounted across the top of the frame rails. All other areas are not meant to support back-of-cab access

CAUTION

Follow these rules for back-of-cab access. Failing to follow these rules could lead to a fall, and possible personal injury.

Never step on any exterior part unless it has a slip-resistant surface meant for safe stepping. If the surface is movable, such as a battery box cover with a slip-resistant surface, be certain it is firmly secured.

Be careful not to trip on items such as chains or air lines in the back-of-cab area.

Always follow safety procedures for back-of-cab access, maintaining three-point contact—both hands and one foot, or both feet and one hand—whenever moving around, and always face in toward the deck plate when climbing up or down.

Wet or dirty shoes, steps, or grab rails greatly increase the chance of slipping or falling. If your shoes or the contact areas are wet or dirty, clean and dry them as much as possible before accessing the back of cab area, and be especially careful when climbing or standing on the vehicle.

Never jump onto, or off of, a vehicle; doing so creates a very high likelihood of a fall and personal injury.

IMPORTANT: Climb onto, and down from, behind the cab while facing in toward the vehicle, as you would on a ladder. Do not climb up or down facing out away from the vehicle.

Accessing Back-of-Cab Area

WARNING

External surfaces of the exhaust system remain hot after the engine has been shut down. When accessing the back of the cab or sleeper, do not touch any part of the exhaust system other than the exhaust-mounted grab handle, if equipped, or severe burns could occur.

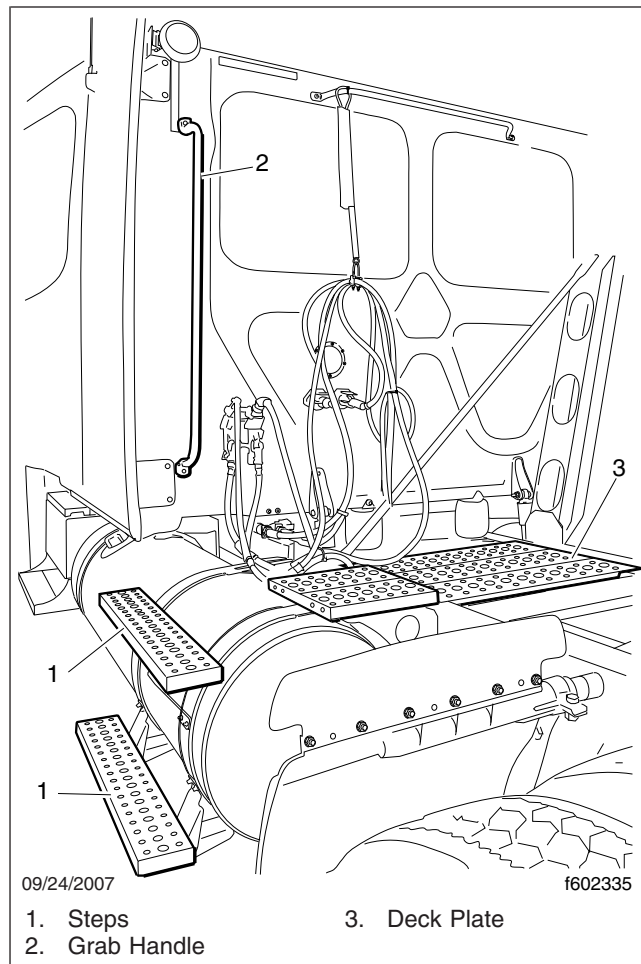

Fig. 2.8, Back-of-Cab Access

1. Facing the deck plate, grasp the grab handle with both hands. Reach up as far as is comfortable.
2. Place one foot on the bottom step and pull yourself up.
3. Place your other foot on the top step.
4. Move your lower hand to a higher position on the grab handle.
5. Step onto the deck plate.

Exiting Back-of-Cab Area

1. Face the center of the vehicle and grasp the sidewall grab handle with both hands.
2. Place one foot at a time on the top step.

Vehicle Access

3. Move your upper hand to a lower position on the grab handle.
4. Move one foot to the bottom step.
5. Step to the ground with your upper foot first.

Hood Opening and Closing

The hood can be raised to a full-open position. A spring helps you to raise the hood, and to lower it to the operating position. In the operating position, the hood is secured to the cab-mounted cowl by a hold-down latch on each side.

Opening the Hood

1. Release both hood hold-down latches by pulling the ends outward.

NOTICE

Do not let the hood free-fall to the full-open position. To do so could cause damage to the hood or hood springs.

2. Using the bumper step for leverage, slowly tilt the hood with both hands on the grab handle. See [Fig. 2.9](#).

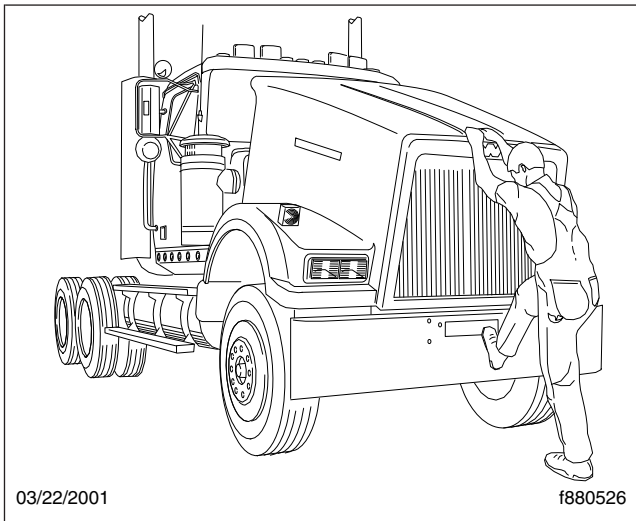

Fig. 2.9, Hood Opening and Closing

3. As the hood starts to open, put your foot on the ground, and walk backwards as you pull. The hood will stop in the full-open position.

Closing the Hood

1. Grasp and lift the grab handle to tilt the hood toward the closed position.
2. As the hood goes over center, put one foot on the bumper step and slowly lower the hood with both hands on the grab handle. See [Fig. 2.9](#).

IMPORTANT: Make sure that both latches are fully engaged before operating the vehicle.

3. Make sure the hood is flush with the cowl, then secure the hood by engaging both hood hold-down latches.

3

Instruments

Warning and Indicator Lights	3.1
Standard Instruments	3.3
Optional Instruments	3.6
Overhead Instrument Panel, Optional	3.8

Instruments

Warning and Indicator Lights

Vehicles built since January 1, 2007 are equipped with a located behind the steering wheel, and contains all standard and optional warning and indicator lamps, or telltales.

See [Table 3.1](#) for a listing of standard and commonly used optional telltales.



The following fixed-position lamps are standard:













- left-turn signal
- high-beam headlights
- daytime running lights
- right-turn signal
- low air pressure
- wait to start (EPA10 and newer vehicles)
- high exhaust system temperature (HEST)
- diesel particulate filter (DPF) status
- malfunction indicator lamp (MIL)
- CHECK engine

- STOP engine
- trailer antilock braking system (ABS)
- tractor ABS
- parking brake engaged

The following lamps are optional:

- rear suspension air pressure
- check transmission
- transmission temperature
- service transmission
- wheel spin
- unfastened seat belt
- intake heater
- water in fuel
- fuel filter restriction
- optimized idle
- power takeoff (PTO) engaged

Common Lightbar Lamps		
	CHECK Engine	Indicates a critical engine condition (low oil pressure, low coolant level, high coolant temperature, high DPF soot level, or uncontrolled DPF regeneration). Correct the condition as soon as possible. If the condition worsens, the STOP engine lamp will illuminate.
	STOP Engine	Indicates a serious fault which requires engine shutdown immediately. The engine protection system will reduce the maximum engine torque and speed, and, if the condition does not improve, will shut down the engine within 30 to 60 seconds. The driver must safely bring the vehicle to a stop on the side of the road and shut down the engine as soon as the red light is seen. If the engine shuts down while the vehicle is in a hazardous location, restart the engine after turning the key to the OFF position for a few seconds. Move the vehicle to a safer location.
	High Exhaust System Temperature (HEST)	Slow (10-second) flashing indicates a regeneration (regen) is in progress. Solid illumination indicates high exhaust temperatures at the outlet of the tail pipe, when speed is below 5 mph (8 km/h). It does not signify the need for service; it only alerts the vehicle operator to high exhaust temperatures when a regen is in progress.

Common Lightbar Lamps		
	Diesel Particulate Filter (DPF) Status	<p>Solid illumination indicates a regen is required. Change to a more challenging duty cycle (such as highway driving) to raise exhaust temperatures for at least twenty minutes, or perform a parked regen.</p> <p>Blinking indicates that a parked regen is required immediately. An engine derate and shutdown will occur.</p>
	Malfunction Indicator Lamp (MIL)	Indicates an engine emissions-related fault. See the engine operation manual for details.
	Left-Turn Arrow	Flashes on and off whenever the outside left-turn signal lights are activated.
	Right-Turn Arrow	Flashes on and off whenever the outside right-turn signal lights are activated.
	High-Beam Headlights	Indicates the high-beam headlights are on.
	Daytime Running Lights	Indicates the daytime running lights are on.
	Tractor ABS	Indicates a problem with the truck/tractor ABS is detected. Repair the vehicle ABS immediately to ensure full braking capability.
	Trailer ABS	Indicates a problem with the trailer ABS is detected. Repair the trailer ABS immediately to ensure full braking capability.
	Low Air Pressure	Activates with an audible warning when air pressure in the primary or secondary reservoir falls below 70 psi (483 kPa).
	Parking Brake	Indicates the parking brake is engaged.
	Power Takeoff (PTO)	Indicates that the PTO function is engaged.
	Unfastened Seat Belt	Illuminates with the ignition ON and the driver seat belt unfastened.
	Water In Fuel	Indicates that the fuel may contain water. The driver must drain any water collected in the fuel/water separator.

Instruments







Common Lightbar Lamps		
	Fuel Filter Restriction	Indicates the fuel filter has been clogged and requires service.
	Wait To Start	Illuminates when starting the engine during cold conditions. Wait until the lamp goes out before turning the ignition key to START.
	Transmission Overheat	Indicates high transmission temperature.
	Check Transmission	Indicates an undesirable transmission condition.
	Service Transmission	Indicates a transmission service is due.
	Rear Suspension Low Air Pressure	Indicates that the rear suspension air pressure is below operating range.
	Wheel Spin	Indicates that the ATC function is engaged.

Table 3.1, Common Lightbar Lamps

Engine Protection System



When the red STOP engine lamp illuminates, most engines are programmed to shut down automatically within 30 seconds. The driver must immediately move the vehicle to a safe location at the side of the road to prevent causing a hazardous situation that could cause bodily injury, property damage, or severe damage to the engine.

The STOP engine lamp illuminates when the engine protection system is activated. On some engines, the engine protection system will derate the engine, allowing it to run at lower rpm and slower vehicle speed. Drive the vehicle to a safe location or to a service facility.

On other engines, the engine protection system will shut down the engine. It will first derate the engine, then shut it down completely 30 to 60 seconds after the indicator illuminates (depending on the critical

fault type) if the condition does not improve. Bring the vehicle to a stop on the side of the road before the engine shuts down.

Some vehicles may have a shutdown-override switch, which may be used to momentarily override the shutdown sequence. See [Chapter 10](#) for detailed information regarding the shutdown process.

IMPORTANT: Do not attempt to restart the engine while the vehicle is moving. Bring the vehicle to a safe stop, then restart the engine.

To restart the engine, turn the ignition switch to OFF, leave it there a few seconds, then turn the switch to START. The engine will run for a short period and shut down again if the condition does not improve.

Standard Instruments

Standard instruments are present on every vehicle. They are listed here in alphabetical order, to make the information easier to find.

Coolant Temperature Gauge

NOTICE

A sudden increase in coolant temperature may indicate engine or cooling system failure. Bring the vehicle to a safe stop and investigate the cause to prevent further damage. Do not operate the engine until the cause has been determined and corrected.

During normal engine operation, the coolant temperature gauge (Fig. 3.1) should read between 175 and 195°F (79 and 91°C). If the temperature remains below 160°F (71°C) or exceeds the maximum temperature shown in Table 3.2, inspect the cooling system to determine the cause.

If coolant temperature rises above the maximum temperature listed in Table 3.2, the CHECK engine lamp will illuminate. If the condition does not improve, the STOP engine lamp will illuminate and an audible warning will sound. The engine will then derate or shut down, depending on the type of engine protection system installed.

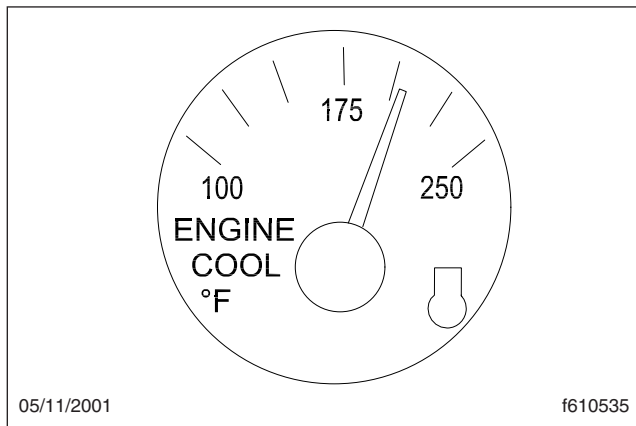

Fig. 3.1, Coolant Temperature Gauge

Maximum Coolant Temperature	
Engine Make	Temperature: °F (°C)
Caterpillar	215 (101)
Cummins	225 (107)
Detroit Diesel	215 (101)
Mercedes-Benz	203 (95)

Table 3.2, Maximum Coolant Temperature

Engine Oil Pressure Gauge

NOTICE

A sudden decrease or absence of oil pressure may indicate mechanical failure. Bring the vehicle to a safe stop and investigate the cause to prevent further damage. Do not operate the engine until the cause has been determined and corrected.

The engine oil pressure gauge (Fig. 3.2) displays the current engine oil pressure. If engine oil pressure falls below the minimum levels shown in Table 3.3, the CHECK engine lamp will illuminate. If the condition does not improve, the STOP engine lamp will illuminate and an audible warning will sound. The engine will then derate or shut down, depending on the type of engine protection system installed.

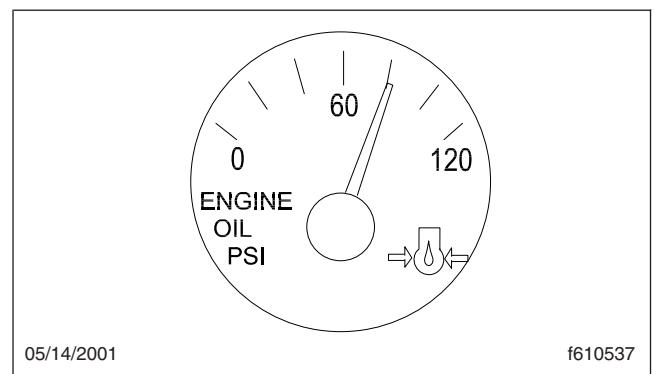

Fig. 3.2, Engine Oil Pressure Gauge

Minimum Oil Pressure *		
Engine Model	At Idle Speed: psi (kPa)	At Rated RPM: psi (kPa)
Caterpillar	10–20 (69–138)	30–45 (207–310)
Cummins	15 (103)	35 (241)
Detroit Diesel	14 (97)	55 (350)
Mercedes-Benz	7 (50)	36 (250)

* Pressures apply with the engine at operating temperature. Oil pressure may be higher on a cold engine. Observe and record pressures when the engine is new to create a guide for checking engine condition.

Table 3.3, Minimum Oil Pressure

Instruments

Fuel/Diesel Exhaust Fluid (DEF) Gauge, EPA10 and Newer

The fuel and DEF levels are measured in a dual purpose fuel/DEF gauge. See [Fig. 3.3](#).

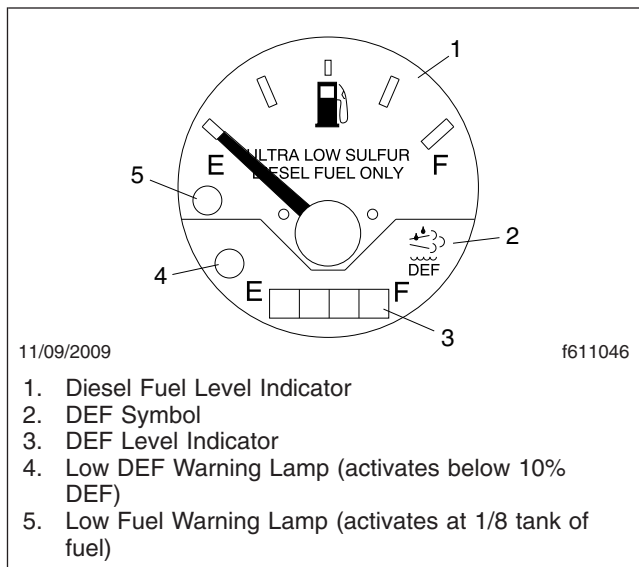

Fig. 3.3, Fuel/DEF Gauge, EPA10 and Newer Vehicles

The diesel fuel level is indicated at the top of the gauge, with a low-fuel warning lamp that illuminates when the diesel fuel level registers 1/8th of capacity.

The DEF level is indicated in the lightbar on the lower portion of the gauge. There is a low DEF level warning lamp that illuminates amber when the DEF level reaches 10% of capacity. See [Chapter 11](#) for details of the DEF gauge functions.

Primary and Secondary Air Pressure Gauges



If air pressure falls below minimum pressure, the braking ability of the vehicle will be limited. Slow the vehicle down and bring it to a gradual stop. Do not attempt to move the vehicle until air pressure has risen above the minimum level. Moving a vehicle without adequate braking power could cause an accident resulting in property damage, personal injury, or death.

Air pressure gauges ([Fig. 3.4](#)) register the pressure in the primary and secondary air systems. Normal pressure with the engine running is 100 to 120 psi (689 to 827 kPa) in both systems.

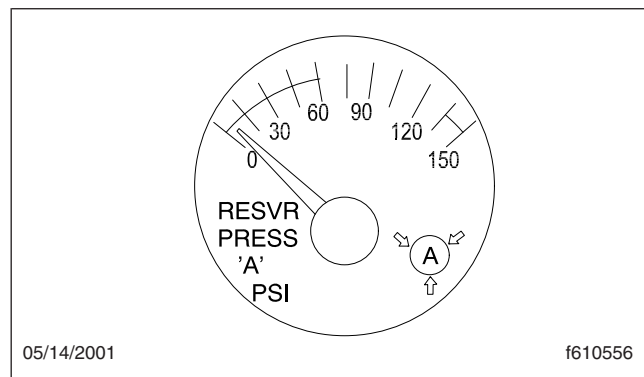

Fig. 3.4, Air Pressure Gauge (reservoir A shown)

A low air pressure warning lamp and audible warning, connected to both the primary and secondary systems, activate when air pressure in either system drops below a minimum pressure of 65 to 75 psi (448 to 517 kPa).

When the engine is started, the warning lamp and audible warning remain on until air pressure in both systems exceeds minimum pressure.

Speedometer

Three speedometer face options are available. The U.S. version of the speedometer ([Fig. 3.5](#)) registers speed in both miles per hour (mph) and kilometers per hour (km/h), with mph in larger numbers.

The metric version of the speedometer face reverses this arrangement, with km/h in larger numbers. The metric-only version, installed on vehicles bound for Australia, shows km/h exclusively.

Tachometer

The tachometer (see [Fig. 3.6](#)) indicates engine speed in revolutions per minute (rpm) and serves as a guide for shifting the transmission and keeping the engine in the appropriate rpm range. For low idle and rated rpm, see the engine identification plate.

Voltmeter

The voltmeter (see [Fig. 3.7](#)) indicates the vehicle charging system voltage when the engine is running

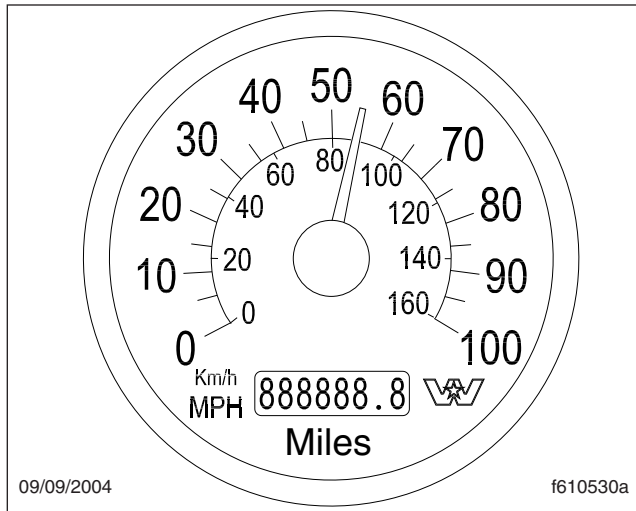

Fig. 3.5, Speedometer (U.S. version)

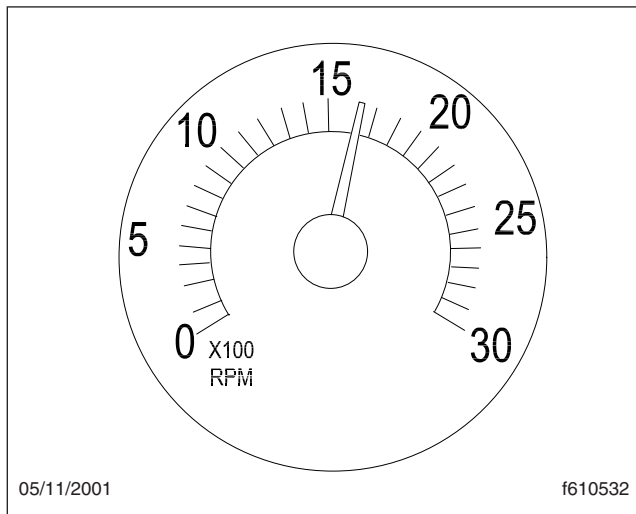

Fig. 3.6, Tachometer

and the battery voltage when the engine is stopped. By monitoring the voltmeter, the driver can stay aware of potential battery charging problems and have them fixed before the batteries discharge enough to create starting difficulties.

The voltmeter will normally show approximately 13.7 to 14.1 volts when the engine is running. The voltage of a fully charged battery is 12.7 to 12.8 volts when the engine is stopped. A completely discharged battery will produce only about 12.0 volts. The voltmeter will indicate lower voltage as the vehicle is being

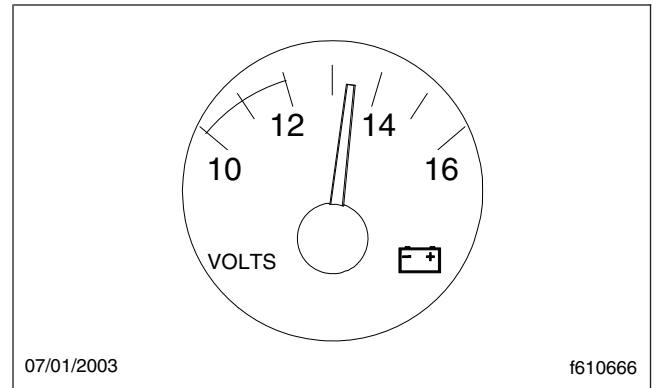

Fig. 3.7, Voltmeter

started or when electrical devices in the vehicle are being used.

If the voltmeter shows an undercharged or overcharged condition for an extended period, have the charging system and batteries checked at a repair facility.

On a vehicle equipped with a battery isolator system, the voltmeter measures the average voltage of all the batteries when the engine is running. When the engine is stopped, the voltmeter shows only the isolated battery voltage and does not indicate the voltage of the engine-starting batteries.

Optional Instruments

Optional instruments are not found on every vehicle. They are listed here in alphabetical order, to make the information easier to find.

Air Restriction Gauge

The air intake restriction gauge measures the vacuum on the engine side of the air cleaner. On standard installations, it is mounted on the air intake duct in the engine compartment. See [Fig. 3.8](#).

As an option for easier viewing, an air intake restriction gauge may be located under the lightbar. See [Fig. 3.9](#).

NOTE: Rain or snow can wet the air filter, causing a temporarily higher than normal reading.

Air intake restriction vacuum is measured in inches of water (inH₂O). For vehicles equipped with a graduated indicator or a restriction gauge on the dash, check the gauge with the engine off. If the air

Instruments

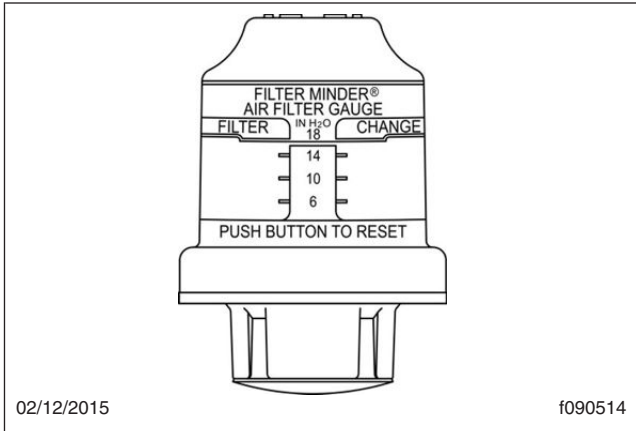

Fig. 3.8, Air Intake Restriction Indicator, Graduated

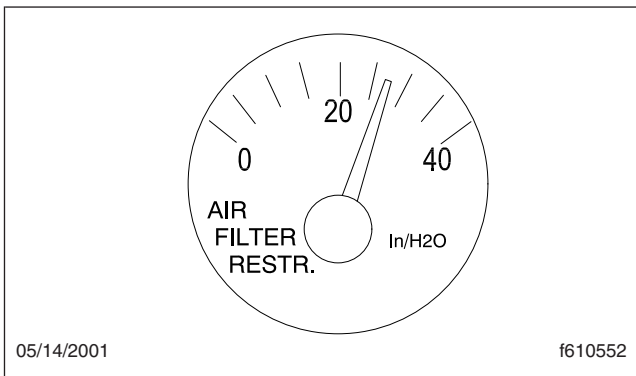

Fig. 3.9, Air Intake Restriction Gauge

restriction value equals or exceeds the value shown in [Table 3.4](#), the air cleaner element needs to be replaced.

Ammeter

The ammeter ([Fig. 3.10](#)) gauge displays current flowing to and from the battery. When the batteries are charging, the meter needle moves to the positive side of the gauge. When the batteries are being discharged, the needle moves to the negative side. A consistent negative reading when the engine is running indicates a possible problem with the charging system.

Air Intake Maximum Restriction Values (inH ₂ O)			
Engine Make	Pre-EPA07 Engines	EPA07 and EPA10 Engines	GHG14 Engines
Cummins	25	25	25
Mercedes-Benz	22	22	–
Caterpillar	25	–	–

Table 3.4, Air Intake Maximum Restriction Values

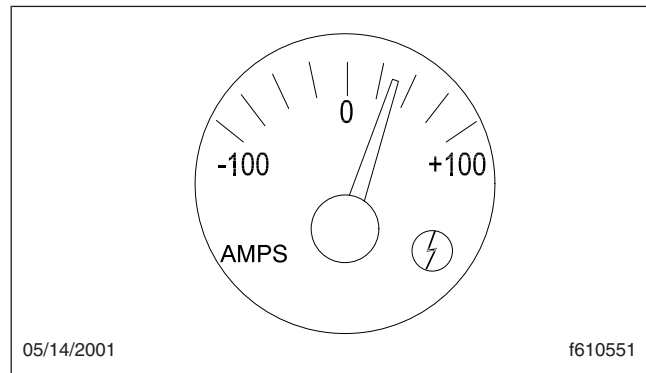

Fig. 3.10, Ammeter

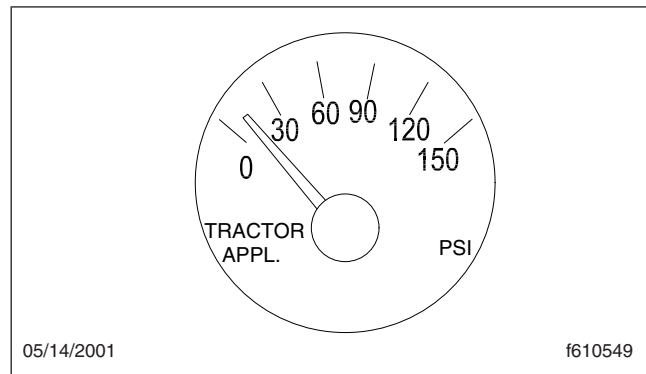

Fig. 3.11, Tractor Application Air Gauge

Application Air Pressure Gauge

The application air pressure gauge ([Fig. 3.11](#)) registers the air pressure being used to apply the brakes, and should be used for reference only. The gauge will not register until the foot pedal is depressed or the hand brake lever is applied.

Air Intake Maximum Restriction Values (inH ₂ O)			
Engine Make	Pre-EPA07 Engines	EPA07 and EPA10 Engines	GHG14 Engines
Detroit	20	22	18

Drive Axle Oil Temperature Gauges

NOTICE

A sudden increase in oil temperature that is not caused by a load increase may indicate mechanical failure. Bring the vehicle to a safe stop and investigate the cause to prevent further damage. Do not operate the vehicle until the cause has been determined and corrected.

During normal operation, drive axle oil temperature gauges (Fig. 3.12) should read between 160 and 220°F (71 and 104°C).

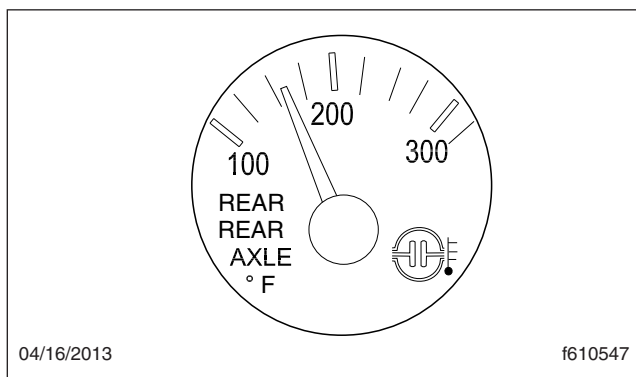

Fig. 3.12, Rear Drive Axle Oil Temperature Gauge

Under heavy loads, such as when climbing steep grades, temperatures that exceed the normal oil temperature range for a short period are not unusual. If the temperature returns to normal when the load decreases, there is no problem.

Engine Oil Temperature Gauge

NOTICE

A sudden increase in oil temperature that is not caused by a load increase may indicate mechanical failure. Bring the vehicle to a safe stop and investigate the cause to prevent further damage. Do not operate the engine until the cause has been determined and corrected.

During normal operation, the engine oil temperature gauge (Fig. 3.13) should read as follows:

- *Cummins engines:* 180 to 225°F (82 to 107°C)
- *Detroit Diesel engines:* 200 to 230°F (93 to 110°C)

Under heavy loads, such as when climbing steep grades, temperatures that exceed the normal oil temperature range for a short period are not unusual. If the temperature returns to normal when the load decreases, there is no problem.

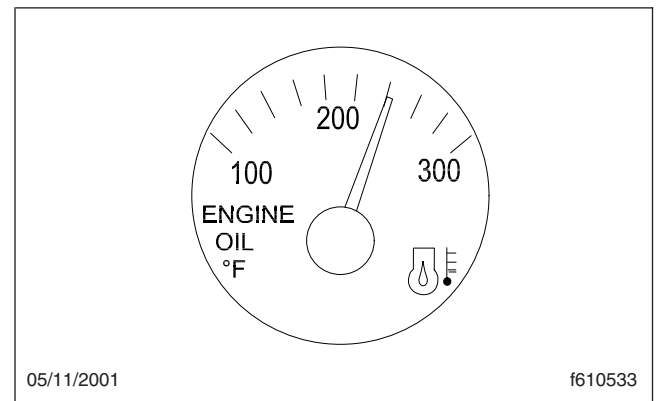

Fig. 3.13, Engine Oil Temperature Gauge

Turbocharger Boost Pressure Gauge

The turbocharger boost pressure gauge (Fig. 3.14) measures the pressure in the intake manifold, in excess of atmospheric pressure, being created by the turbocharger.

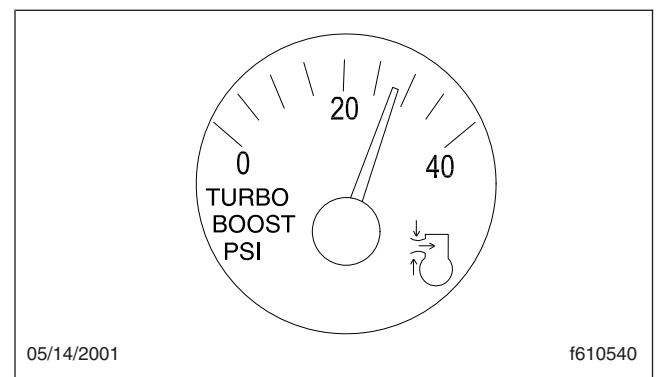

Fig. 3.14, Turbocharger Boost Pressure Gauge

Overhead Instrument Panel, Optional

The optional overhead instrument panel may hold a citizen's band (C/B) radio, AM/FM radio, and storage area with netting. The underside of the overhead

Instruments

console also holds the sun visors and the optional dome/reading light assembly. For more information on the dome/reading light assembly, see [Chapter 7](#).

4

Driver Controls

Control Panels	4.1
Ignition Switch	4.1
Lighting Controls	4.3
Horn Controls	4.5
Powertrain Controls	4.6
Windshield Wiper Controls	4.11
Brake Controls	4.11
Adjustable Steering Column Controls	4.12
Suspension/Trailer Connection Controls	4.13
Climate Controls	4.13
Seat Controls	4.14

Driver Controls

Control Panels

NOTE: Western Star vehicles are offered with various chassis and body components. Because of the various options, the information contained in this chapter may not apply to every vehicle.

The right-hand dash control panel contains a face vent, the majority of the driver switch controls, automated and automatic transmission controls, and the DataStar display module, if equipped. If there is a dash-mounted air intake restriction indicator, it is often mounted on the right-hand panel as well.

The ignition switch control panel (below the right-hand dash panel) contains the ignition switch, cigarette lighter, and climate controls.

The lightbar and instrument gauges are located behind the steering wheel.

NOTE: Control locations may vary from those shown depending on vehicle options.

Figure 4.1 shows typical lower dash panel controls; figure 4.2 shows typical upper dash panel controls

DataStar Display Module

The DataStar display module, shown in Fig. 4.3, displays operator-selected vehicle and engine parameters for the time and distance of up to six different trips. Four keys allow the operator to scroll through the vehicle parameters, set the time and alarm, and reset trip logs.

Battery input powers the DataStar display and must be continuously connected for the clock to maintain the time. When the ignition is on, the DataStar is fully functional. Turning the ignition off puts the DataStar display into sleep mode, and the display turns off to reduce current drain. When the ignition is turned on again, the DataStar display will come up in the same mode it was in when the ignition was turned off.

Ignition Switch

The ignition switch has four positions: OFF, ACCESSORY, ON, and START. See Fig. 4.4.

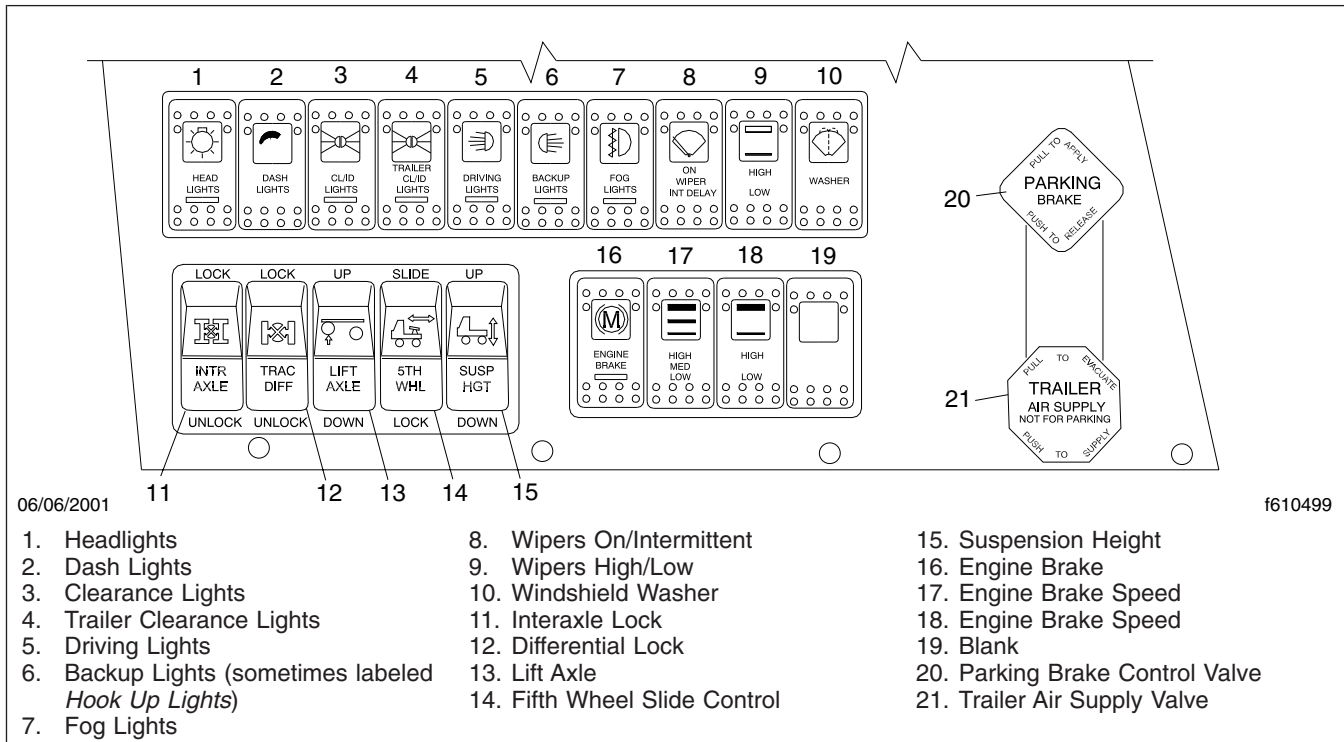

Fig. 4.1, Lower Dash Control Panel

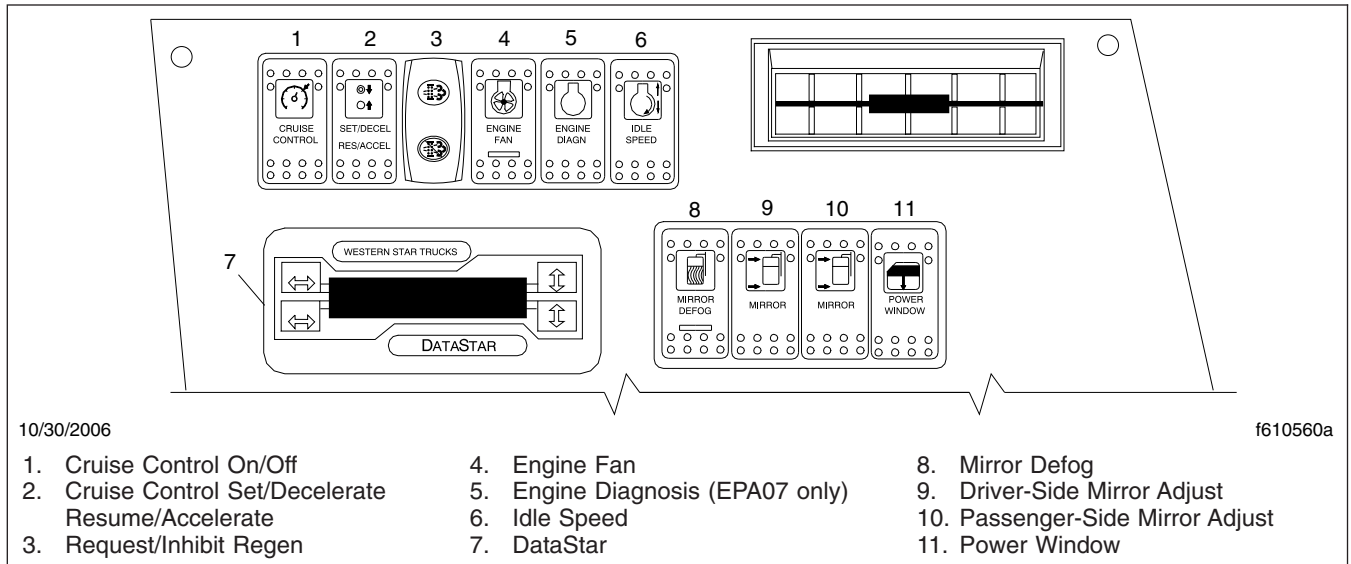

Fig. 4.2, Upper Dash Control Panel

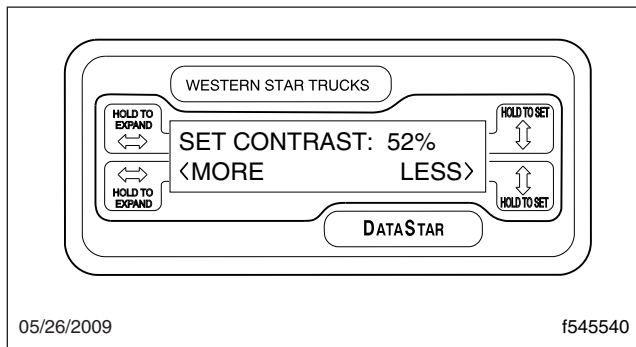

Fig. 4.3, DataStar LCD Display Module

In the OFF position, the key slot is vertical. The key can be inserted and removed only in the OFF position.

The following functions are operable when the ignition switch is in the OFF position (regardless of whether the key is inserted):

- high-beam headlights
- taillights
- brake lights
- road lights
- dome lights
- clearance lights
- turn signals
- hazard warning lights
- utility and baggage lights
- spotlights
- electric horn
- clock
- refrigerator
- television

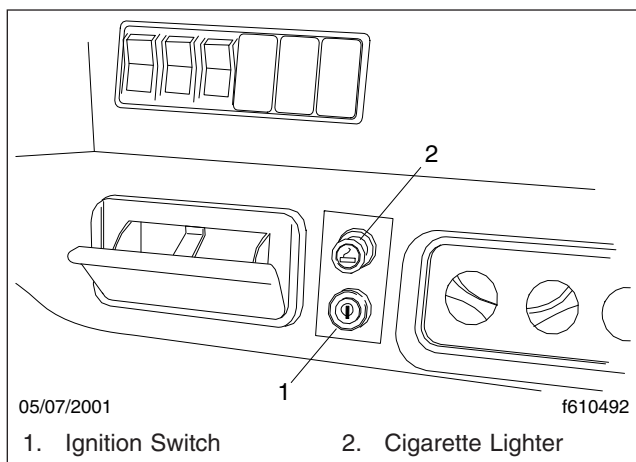

Fig. 4.4, Ignition Switch and Cigarette Lighter

Driver Controls

Turn the key counterclockwise to the ACCESSORY position. In addition to all the functions that are operable with the ignition switch in the OFF position, the following functions are operable when the switch is in the ACCESSORY position:

- radio/stereo system
- heater and A/C fan
- mirror defog
- windshield wipers
- beacons
- power windows
- windshield washer
- outside air temperature display

Turn the key clockwise past the OFF position to the ON position. With the switch in the ON position, the warning and indicator lamps illuminate. Wait for three seconds before starting the engine.

Turn the key clockwise past the ON position to the START position and start the engine. Do not operate the starter longer than thirty seconds, and wait at least two minutes between starting attempts to allow the starter to cool. Release the key the moment the engine starts.

Switching on the ignition and releasing the parking brake automatically activates the daytime running lights, if equipped. The daytime running lights will operate until the parking brake is applied or the headlights are turned on.

Lighting Controls

IMPORTANT: Unless otherwise noted below, press the upper half of the switch to activate the desired light(s). Press the lower half of the switch to turn the light(s) off.

Exterior Light Controls

Exterior light controls are listed here in alphabetical order. See [Fig. 4.5](#) for exterior light locations. At the rear of the vehicle there are taillights, brake lights with turn signals, backup lights, and optional utility lights.

See [Fig. 4.6](#) for exterior and interior light switches.

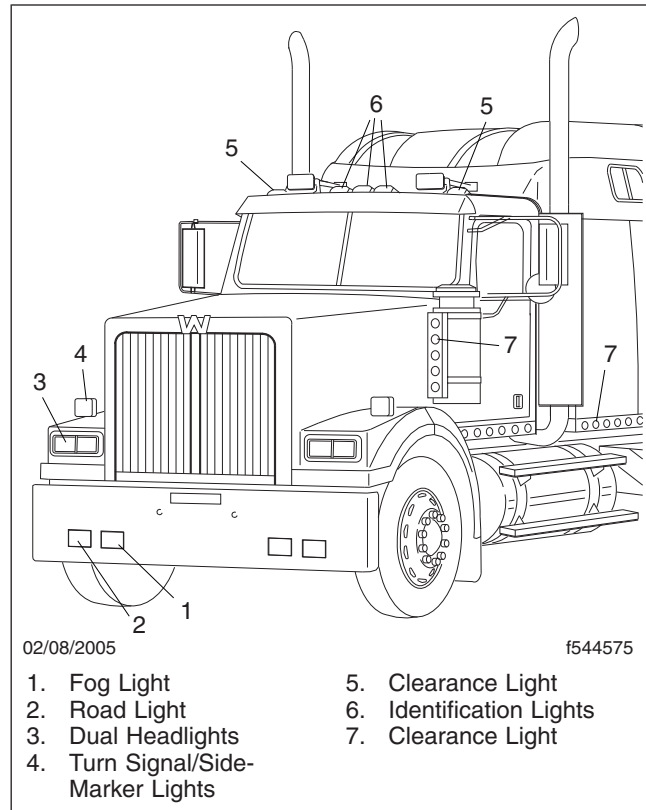

Fig. 4.5, Exterior Lights

Backup Lights

NOTE: Depending on the mounting, backup lights are sometimes referred to as hook-up lights.

Backup lights activate only when the vehicle is in reverse, and are designed to be used while backing up at night.

Clearance Lights

Press the upper half of the clearance lights switch to activate all clearance lamps including back-of-sleeper and mirrors.

Driving Lights

Driving lights are designed to extend the range of the high-beam headlights, and can only be activated when the headlight high-beams are on. When headlights are dimmed, the driving lights automatically turn off.

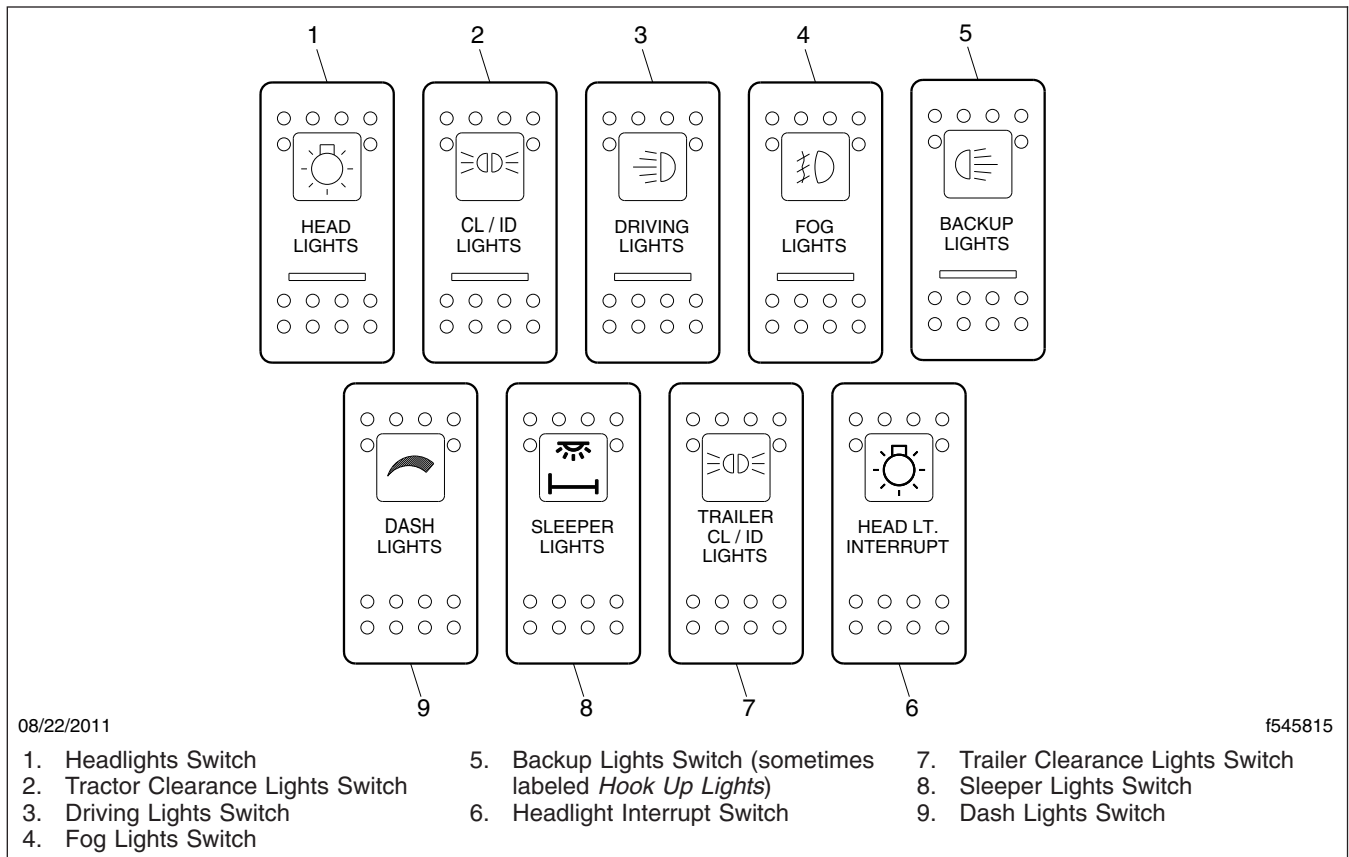

Fig. 4.6, Exterior and Interior Light Switches

Fog Lights

Fog lights are designed to reduce glare in foggy conditions. The headlights must be on and set on low beam for the fog lights to activate.

Hazard Warning Lights

The hazard flasher switch is located underneath the turn signal lever, as shown in [Fig. 4.7](#). Pull the hazard light switch tab out to activate all of the turn signal lights and both of the telltales on the lightbar will flash. To cancel the hazard lights, move the turn signal lever up or down.

Western Star vehicles may be equipped with an optional hazard light switch located on the right-hand dash panel. To operate the hazard lights, press the upper half of the switch. To cancel the hazard lights, press the lower half of the switch.

Headlight Interrupt

When the headlight interrupt switch is activated, the daytime running lights blink. The headlight interrupt switch only operates when the headlights are on.

Headlights

The headlight switch is operated by pushing the upper half of the switch once for the parking lights, illuminating the taillights and side marker lamps on both the tractor and trailer. Pressing the upper half of the switch a second time activates the headlights. An audible warning will sound if the lights are left on when the ignition is turned off.

High-Beam Headlights

With the low-beam headlights on, push the button on the end of the turn-signal lever to turn on the high-beam headlights. See [Fig. 4.7](#). Push the button again to turn the high-beams off.

Driver Controls

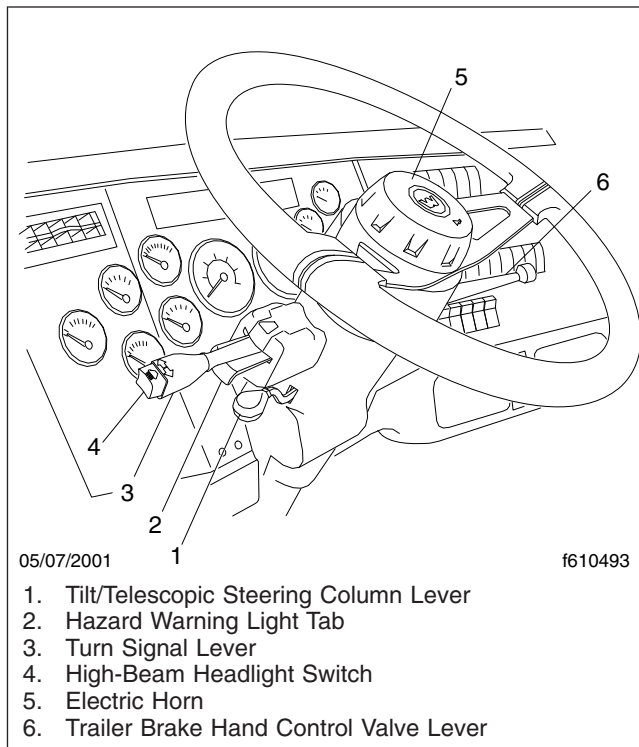

Fig. 4.7, Steering Column-Mounted Controls

When the high-beam headlights are on, a blue light illuminates on the lightbar.

Trailer Clearance Lights

The trailer clearance lights switch activates the trailer clearance lamps independent of the tractor lamps.

Turn Signals

The turn-signal switch is typically a non-canceling combination turn-signal, hazard, and headlight-dimmer unit that mounts to a bracket on the left side of the steering column. See [Fig. 4.7](#).

Moving the turn signal switch down turns on the left-turn signal; moving it up turns on the right-turn signal. To manually cancel the signal, move the lever to the neutral position.

When a turn signal is activated, a green telltale light flashes on the lightbar.

On a self-canceling turn signal switch, the switch automatically returns to the neutral position when the steering wheel returns to the straight ahead position after a turn.

Interior Light Controls

The cab is equipped with a dome light and optional high-intensity reading lights. The sleeper section is equipped with accessory lights and high-intensity reading lights. Baggage compartments may be equipped with accessory lights.

When the panel lights are on, most switch icons are backlit with a colored light to allow the driver to find switches more easily in the dark. When a switch is activated, the lightbar on the switch is backlit with a colored light.

Dash Lights

The dash lights switch is operated by pushing the upper half of the switch and holding to obtain the brightness desired. Pushing and holding the lower half of the switch will dim the dash lights.

Overhead Console Lights

In cabs with an overhead console, there is an optional overhead light assembly containing a diffuse dome light and clear reading lights.

Rear Dome Light

The standard rear dome light is installed on the back of the cab above the rear window.

Horn Controls

Air Horn

The air horn is controlled by a wire lanyard hanging from the center of the overhead console. Pull downward on the lanyard to sound the air horn.

Electric Horn

The electric horn button is located in the center of the steering wheel. See [Fig. 4.7](#). To sound the horn, press down on the button. The horn will sound as long as the button is pressed, up to 60 seconds.

Powertrain Controls

Aftertreatment System Regen Switches

NOTE: See [Chapter 11](#) for detailed information about the operation of the regeneration (regen) switches and the aftertreatment system (ATS).

The regen request switch is used to initiate a parked regen. See [Fig. 4.8](#).

Some vehicles may be equipped with an optional regen request/inhibit switch; see [Fig. 4.9](#). To request a parked regen, press the upper half of the switch. To stop a regen in progress or prevent the start of a regen, press the lower half of the switch. Regen will not occur until the switch is no longer active.

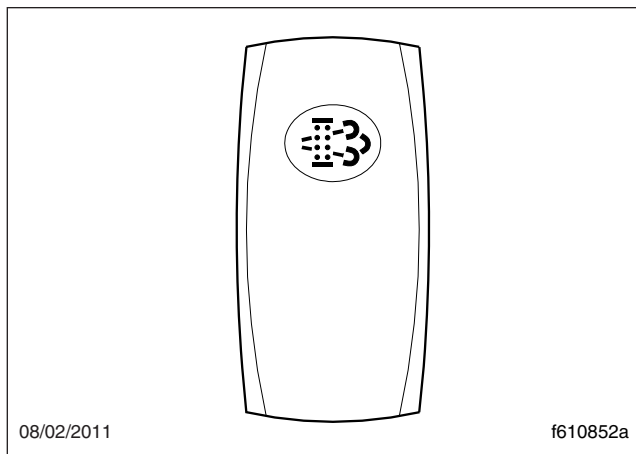

Fig. 4.8, Regen Request Switch

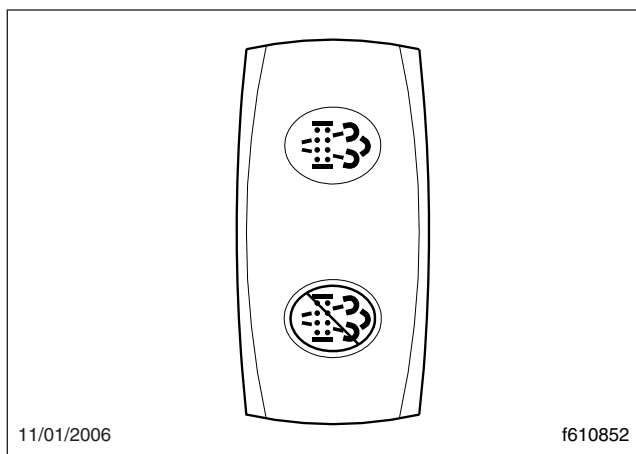

Fig. 4.9, Regen Request/Inhibit Switch

Axle Switches

Axle switch controls are listed here in alphabetical order.

NOTE: See [Chapter 16](#) for detailed information about axle switch functions.

Differential Lock Switch

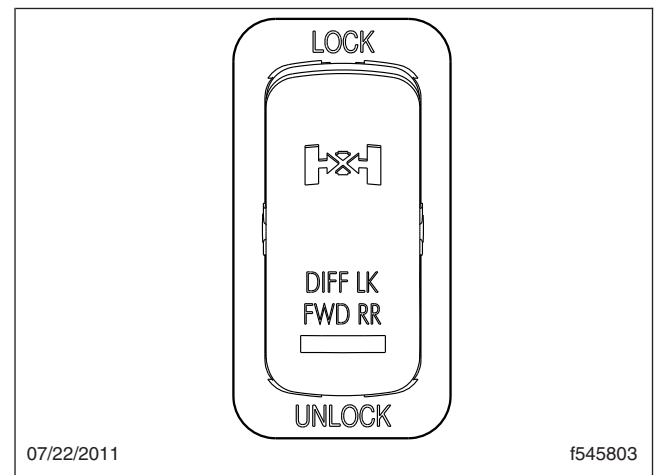

Fig. 4.10, Forward Drive Axle Differential Lock Switch

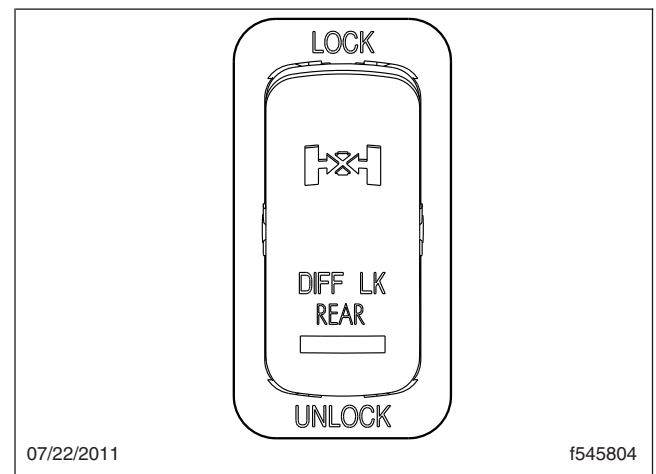

Fig. 4.11, Rear Drive Axle Differential Lock Switch

The differential lock switch, as shown in [Fig. 4.10](#) or [Fig. 4.11](#), provides maximum traction for slippery conditions by forcing the wheels on each drive axle governed by the switch to rotate together. Engagement can be at any speed, provided the wheels are not slipping or spinning.

Driver Controls

Interaxle Lock Switch

The interaxle lock switch allows the driver to lock the drive axles together, causing the drive axle shafts to rotate together. See [Fig. 4.12](#). Use this feature only under adverse road conditions where greater traction is needed.

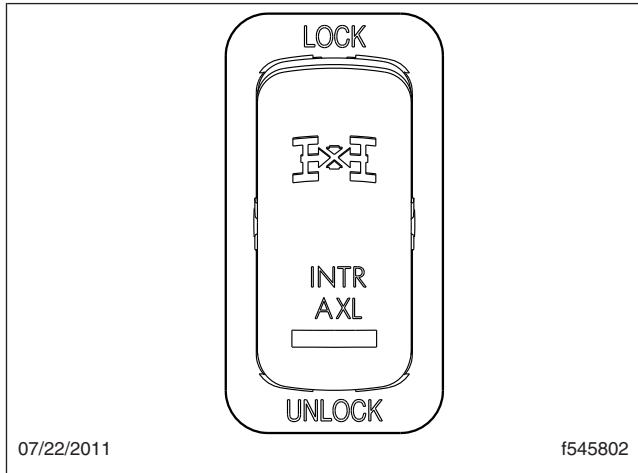

Fig. 4.12, Interaxle Lock Switch

Leave the control in the UNLOCK position for normal highway operation. When a spinning or slipping action occurs at any of the drive wheels, press the upper half of the switch to LOCK the differential and prevent the wheels from spinning.

NOTICE

Do not shift into LOCK while the rear wheels are spinning. Come to a halt before engaging to prevent damage to the interaxle and main differentials.

Do not permit rear wheels to spin freely for more than ten seconds when traction is lost. Shift into LOCK to prevent damage to the interaxle and main differentials.

Lift Axle Switch

The lift axle switch controls the lift axle operation. See [Fig. 4.13](#). Pushing the upper half of the switch will lower the lift axle.

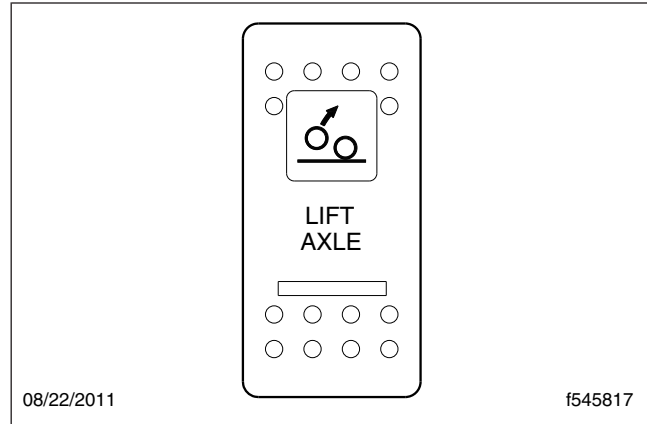

Fig. 4.13, Lift Axle Switch

Cruise Control Switches

NOTE: See [Chapter 10](#) for detailed information about cruise control operation.

On/Off Switch

Press the upper half of the cruise control on/off switch to activate it. See [Fig. 4.14](#).

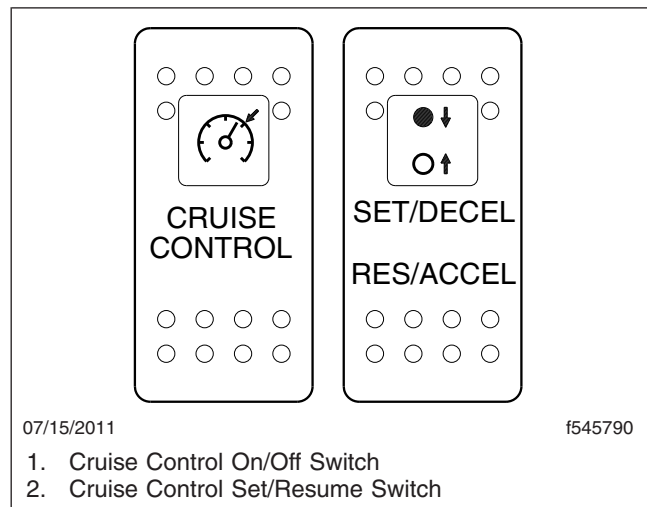

Fig. 4.14, Cruise Control Switches

NOTE: Cruise control is canceled if the brake or clutch pedal is depressed, or engine speed drops below 1200 rpm.

Set/Decelerate/Resume/Accelerate Switch

The set/decelerate/resume/accelerate switch can only be used when cruise control has been activated. See [Fig. 4.14](#).

Press the upper half of the switch momentarily to set the cruise speed (with the engine running at the desired speed). Press and hold the upper half of the switch to decelerate slowly. Release the switch when the desired speed is reached.

Press the lower half of the switch momentarily to resume the previously set cruise speed. Press the lower half of the switch and hold to accelerate slowly. Release the switch when the desired speed is achieved.

NOTICE

When the cruise control is engaged, do not attempt to shift gears without using the clutch pedal. Failure to follow this precaution will result in a temporarily uncontrolled increase in engine speed. Transmission damage and gear stripping could result.

Engine Brake Switches

NOTE: See [Chapter 10](#) for detailed information about engine brake operation.

Whenever vehicle braking is required on good road conditions, the engine brake may be used in conjunction with the service brakes. There is no time limit for operation of the engine brake. However, an engine brake does not provide the precise control of, and is not a substitute for, service brakes.

Two dash-mounted switches control the engine brake:

- The ENGINE BRAKE switch is used to turn the engine brake on and off. See [Fig. 4.15](#).
- The HIGH/MED/LOW engine brake intensity switch (HIGH/LOW in some cases) controls the amount of engine braking. When the engine brake is on, the status bar illuminates, indicating the current intensity setting.

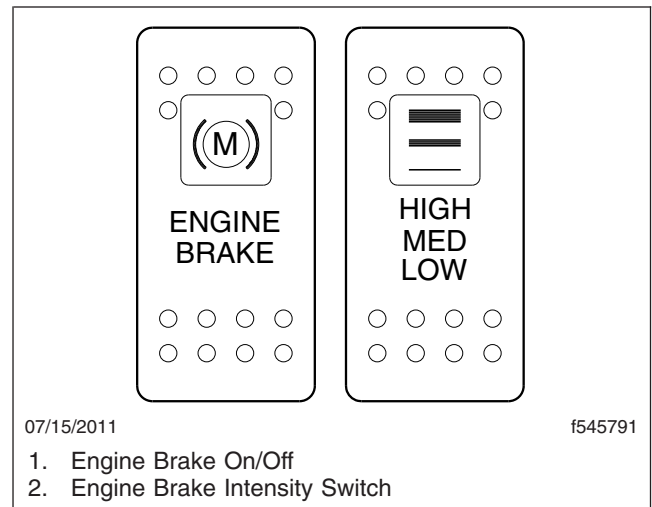

Fig. 4.15, Engine Brake Switches

Engine Diagnostic Switch (EPA07 vehicles)

The engine diagnostic switch is used to signal the engine ECM to flash codes on the indicator light. Press the upper half of the switch once to activate it. See [Fig. 4.16](#).

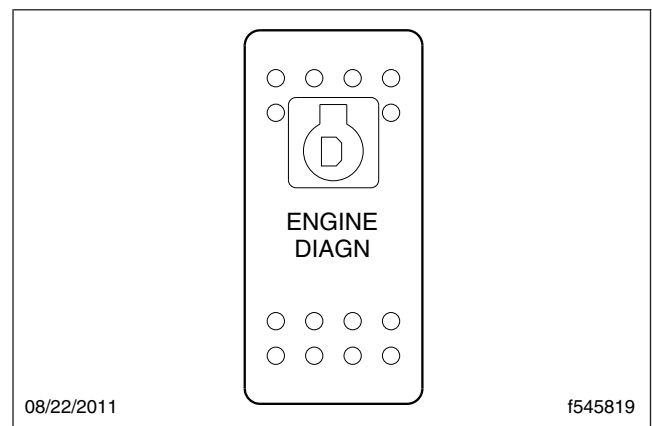

Fig. 4.16, Engine Diagnostic Switch

Engine Fan Switch

Press the upper half of the engine fan switch to override the automatic fan control and cause the engine fan to run continuously. See [Fig. 4.17](#). This switch is intended for temporary use, or if the automatic fan control fails. Press the lower half of the switch to return to automatic fan control.

Driver Controls

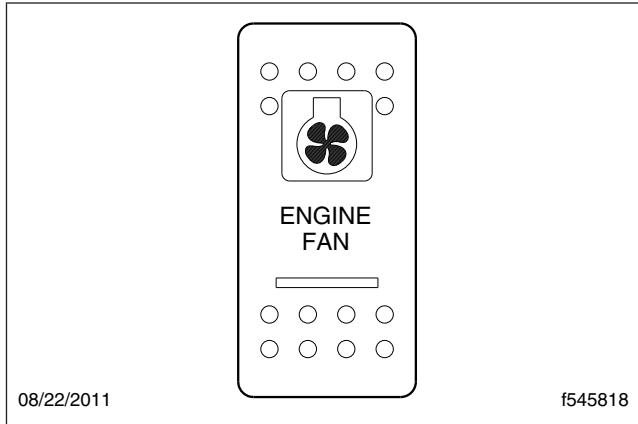

Fig. 4.17, Engine Fan Switch

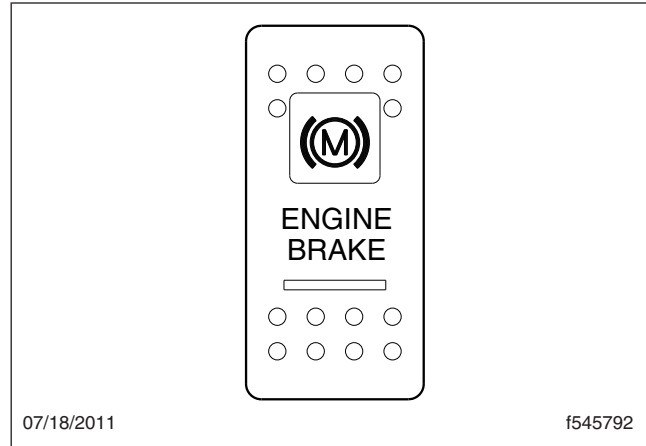

Fig. 4.18, Exhaust Brake Switch

Exhaust Brake Switch

NOTE: See [Chapter 10](#) for detailed information about exhaust brake operation.

An exhaust brake is an optional auxiliary braking system that assists but does not replace the service brake system on vehicles with Cummins engines. The exhaust brake may be used in conjunction with the service brakes in off-highway and mountain driving as well as in traffic or high-speed highway driving. Exhaust brakes are not intended for use as the primary braking system during vehicle operation.

To turn the exhaust brake on, press the upper half of the rocker switch. See [Fig. 4.18](#).

The exhaust brake turns itself off automatically. In addition, depressing the accelerator or clutch pedal deactivates the exhaust brake. The ABS, when active, also deactivates the exhaust brake.

Idle Speed Switch

The idle speed switch may be installed on vehicles with Cummins engines to change the idle speed of the engine. See [Fig. 4.19](#).

Power Takeoff Controls

Engine power takeoffs (PTO) are devices used to tap into engine power to run auxiliary devices, such as hydraulic pumps that power additional equipment. The following instructions are general guidelines for operating a PTO.

1. Set the parking brake and put the transmission in neutral.

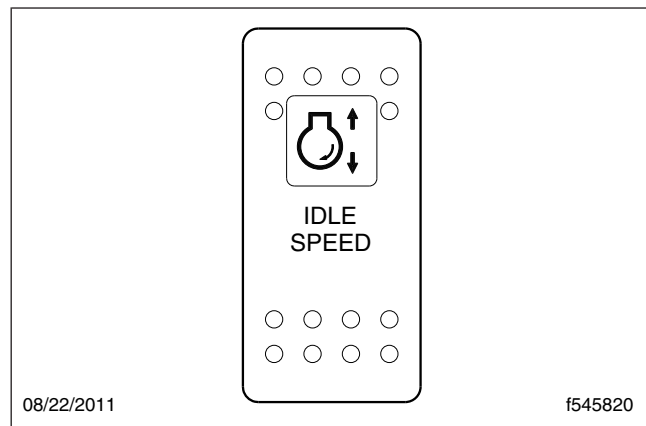

Fig. 4.19, Idle Speed Switch (Cummins engines)

2. Press the PTO switch. See [Fig. 4.20](#). When the light is steadily illuminated, the PTO is engaged and ready to operate. In stationary mode, the vehicle must remain in neutral with the parking brake set.
3. To activate the mobile mode, shift from neutral to reverse, 1st, or 2nd gear. The clutch will open and the PTO will disengage for a moment.
4. Touch the accelerator pedal to close the clutch and engage the PTO in mobile mode. The PTO may be operated with the transmission in reverse, neutral, 1st, or 2nd gear only.

NOTE: Do not attempt to change gears while the vehicle is moving. The transmission will ignore the request.

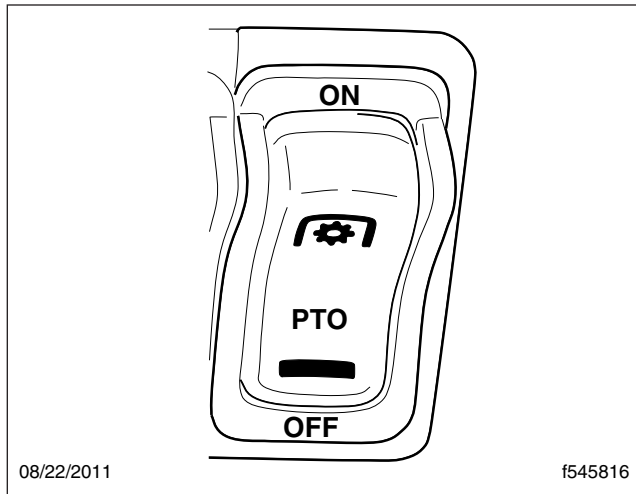

Fig. 4.20, PTO Switch

5. To end the mobile mode, bring the vehicle to a stop. The clutch will open and shut down power to the PTO.
6. To resume stationary mode, shift to neutral. The PTO will engage.
7. To end stationary mode, press the dash switch. When the light in the switch goes out, power to the PTO is shut off.

Transmission Controls

Manual Transmissions

NOTE: See [Chapter 14](#) for complete manual transmission operating instructions.

if equipped, the transmission range control and splitter valves are attached to the gear shift knob.

To operate a range-shift transmission, move the shift knob through all the low-range gear positions and then pull the range-preselection lever up to move into the high-range ratios. Use the same shift knob positions in both the low and high ranges.

Dependent on the transmission model, some ratios can be split using the splitter-control button (located on the side of the shift knob).

Eaton Automated Transmissions

NOTE: See [Chapter 15](#) for complete automated transmission operating instructions.

Eaton Fuller automated transmissions use a shift selection module. See [Fig. 4.21](#). Shifts can be made automatically, or manually using the shift selection module.

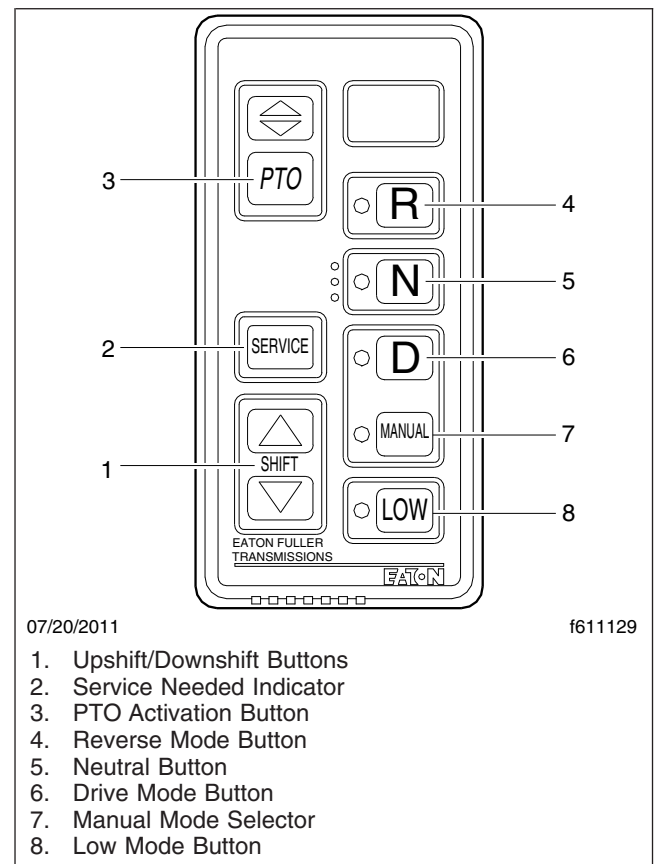

Fig. 4.21, Shift Selection Module, UltraShift and AutoShift Transmissions

07/20/2011

f611129

1. Upshift/Downshift Buttons
2. Service Needed Indicator
3. PTO Activation Button
4. Reverse Mode Button
5. Neutral Button
6. Drive Mode Button
7. Manual Mode Selector
8. Low Mode Button

The current gear is displayed on the gear indicator. At the start of a shift, the current gear continues to display until the transmission has been pulled into neutral. As the transmission is synchronizing for the new (target) gear, the gear indicator flashes the number of the target gear. When the shift is complete, the gear indicator displays the new gear, without flashing.

Allison Automatic Transmissions

NOTE: See [Chapter 15](#) for complete automatic transmission operating instructions.

HD-series automatic transmissions have six forward speeds and one reverse speed. These transmissions

Driver Controls

have electronic shift controls that can be programmed to allow the use of different numbers of geared speeds. See [Fig. 4.22](#).

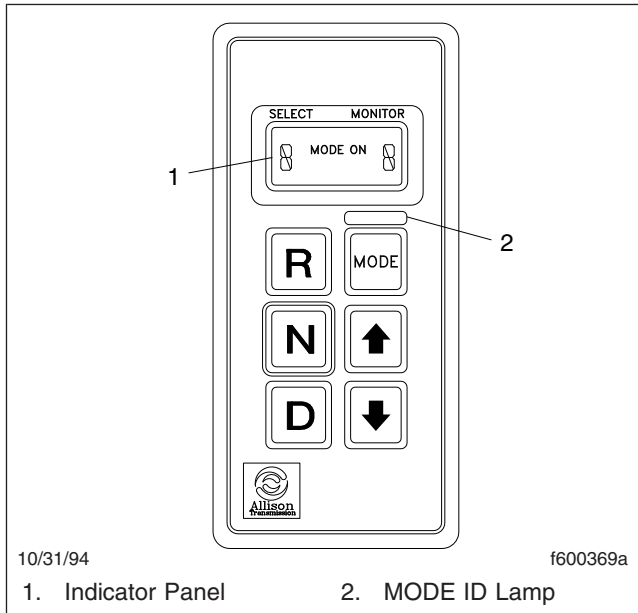

Fig. 4.22, Allison Shift Selector

Windshield Wiper Controls

The windshield wipers are operated by two rocker switches located on the lower right-hand dash control panel. See [Fig. 4.23](#). The 3-position ON–WIPER–INT DELAY switch turns the wipers on and off, and controls intermittent wiper operation. The HIGH/LOW switch controls constant speed wiper operation.

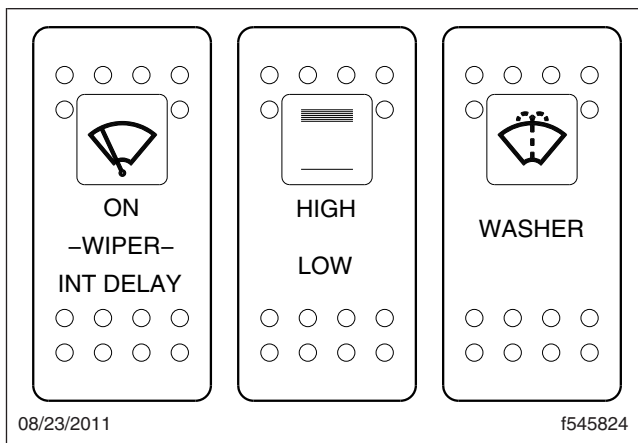

Fig. 4.23, Windshield Wiper Switches

To turn the windshield wipers on at a constant speed, press the upper half of the ON–WIPER–INT DELAY switch. Press the upper half of the HIGH/LOW switch to select high speed; press the lower of the HIGH/LOW switch to select low speed.

To turn the windshield wipers off, move the ON–WIPER–INT DELAY switch to the middle (WIPER) position.

To turn the windshield wipers on intermittently, press the lower half of the ON–WIPER–INT DELAY switch. The default intermittent interval is six seconds.

The interval can be changed by turning the wipers off for a specific period of time, then pressing the lower half of the ON–WIPER–INT DELAY switch again to activate the desired interval. See [Table 4.1](#) for settings.

Setting Intermittent Wiper Operation	
Switch Off Interval	Wiper Interval
Less than 1 second	1 second
1 to 25 seconds	Interval set to the period switch is in the Off position (1 to 25 seconds)
25 to 50 seconds	25 seconds
More than 50 seconds	6 seconds

Table 4.1, Setting Intermittent Wiper Operation

The windshield washers are operated by a rocker switch labeled WASHER, located on the lower right-hand dash control panel. See [Fig. 4.23](#). Press and hold the upper half of the washer switch to spray the windshield. Release the switch when enough washer fluid has been sprayed on the windshield.

Brake Controls

NOTE: See [Chapter 12](#) for detailed information about brake systems.

Parking Brake Control Valve

The parking brake control valve applies both the tractor and trailer spring parking brakes. See [Fig. 4.24](#), Item 2. Pushing the knob in releases the spring parking brakes.

If the trailer is not equipped with spring parking brakes, pulling out the parking brake valve applies the tractor parking brakes and the trailer service brakes.

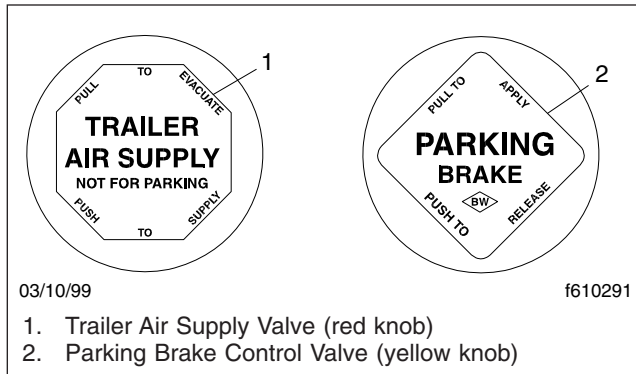

Fig. 4.24, Brake Valve Knobs

Trailer Air Supply Valve

The trailer air supply valve charges the trailer air supply system and releases the trailer spring parking brakes. See [Fig. 4.24](#), Item 1.

Pull the trailer air supply valve out before disconnecting a trailer or when operating a vehicle without a trailer.

Trailer Brake Lever

The trailer brake lever, located on the right-hand side of the steering column is used for applying the trailer service brakes without applying the truck or tractor service brakes. See [Fig. 4.7](#), Item 6. The valve can be partially or fully applied, but in any partially-on position it will be overridden by a full application of the service brake pedal. Moving the lever down applies the trailer brakes, while moving it up releases the trailer brakes. The lever will automatically return to the up position when it is released.

Antilock Braking System

The Meritor WABCO® Antilock Braking System (ABS) controls wheel speed during emergency stops or wheel lock situations.

During emergency or reduced-traction stops, fully depress the brake pedal until the vehicle comes to a safe stop. *Do not pump the brake pedal.* With the brake pedal fully depressed, the ABS will control all wheels to provide steering control and a reduced braking distance.

Vehicles with ABS may have Automatic Traction Control (ATC). The ATC system automatically limits wheel spin during reduced-traction situations. If the vehicle has ATC, there will be an ATC switch located

on the right-hand control panel. See [Fig. 4.25](#). Pressing the switch will temporarily allow more drive wheel spin. Pressing the switch again will cause the system to go back to normal operation.

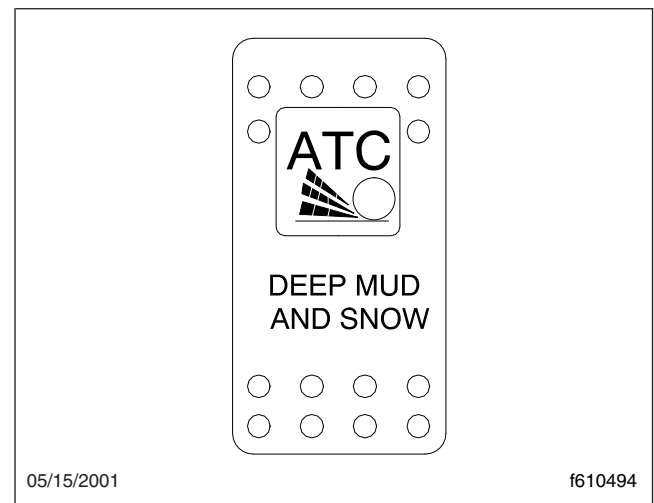

Fig. 4.25, ATC Switch

NOTICE

The ATC option is intended to be used under specific slippery conditions that require momentary increased wheel spin. Using this option for an extended period of time may damage the vehicle brake system.

Adjustable Steering Column Controls

Adjust the seat to the desired ride position, then tilt or telescope the steering column as needed using the steering column lever in [Fig. 4.7](#).

To tilt the steering column, pull the lever up toward the driver. Tilt the wheel to the desired position and release the lever.

To telescope the steering column, push the lever down (away from the driver) and pull or push the steering wheel to the desired position. Release the lever to lock the steering column in place.

Driver Controls

WARNING

Make sure that the control lever is back in the neutral position and the steering column is locked before driving the vehicle. Never tilt the column while driving the vehicle. Doing so could cause loss of vehicle control, personal injury, and property damage.

Suspension/Trailer Connection Controls

Air-Suspension Dump Control Switch

NOTICE

Do not operate the vehicle over uneven ground such as ramps, speed bumps, curbs, etc., with the air springs deflated. Doing this may lead to air bag separation from the piston, preventing the suspension air springs from inflating.

The suspension dump switch allows the air in the air suspension to be quickly exhausted, lowering the rear of the vehicle. [Fig. 4.26](#). This makes it easier to connect to, or disconnect from, a trailer.

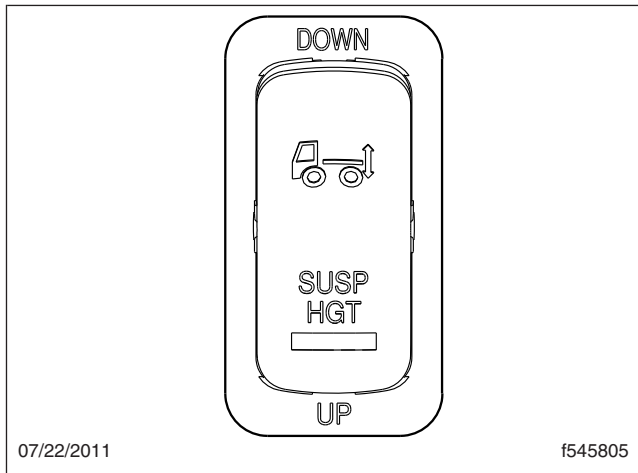

Fig. 4.26, Air-Suspension Dump Switch

NOTICE

Never exhaust air from the suspension while driving. When the air is exhausted, the suspen-

sion will not absorb road shocks and components may be damaged.

To lower the rear of the vehicle, press the upper half of the rocker momentarily. To raise the suspension to its normal height, press the lower half of the switch.

Fifth Wheel Slide Control Switch

NOTICE

Do not activate the fifth wheel slide control valve while the vehicle is in motion. To do so could cause damage to the fifth wheel member, the kingpin, the cab or trailer, and ultimately to the drivetrain.

The fifth wheel air slide switch permits repositioning of the sliding fifth wheel from inside the cab. See [Fig. 4.27](#). Moving the air slide control valve switch to the lock position deactivates the control valve and locks the fifth wheel to the baseplate. Moving the switch to the unlock position activates the control valve and unlocks the fifth wheel slide mechanism, allowing changes to the total length of the tractor-trailer and changes to axle loads to comply with varying jurisdictional laws. For detailed operating instructions for fifth wheel slide, coupling, and uncoupling procedures, refer to [Chapter 17](#).

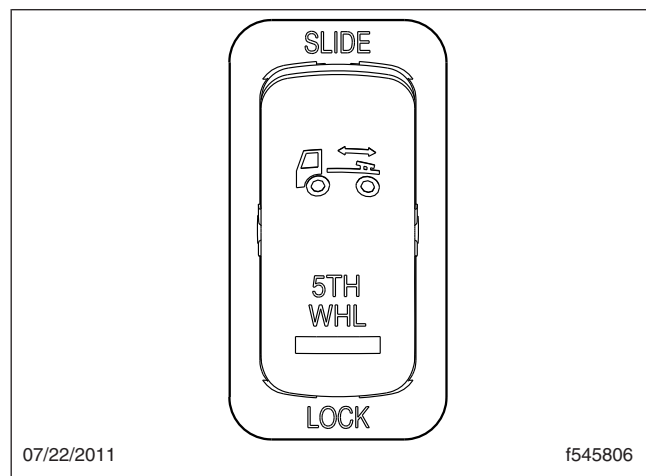

Fig. 4.27, Fifth Wheel Slide Control Switch

Climate Controls

NOTE: See [Chapter 5](#) for detailed climate control panel operating instructions.

The climate control panel allows you to control the heating, ventilating, defrosting, and air conditioning functions. Western Star vehicles have several heater and air conditioner options.

Options for the cab include:

- heater only
- heater and air conditioner
- heater and air conditioner with automatic temperature control (ATC)

Options for a sleeper unit include:

- no heater or air conditioner
- heater only
- heater and air conditioner
- heater and air conditioner with ATC

The ATC feature automatically controls the heating and cooling system to maintain the cab and sleeper air temperature close to the temperature set by the user. The ATC adjusts the air temperature blown through the air outlets to maintain the selected temperature.

Seat Controls

NOTE: See [Chapter 6](#) for detailed information about seat controls and adjustments.

WARNING

Keep hands, tools, and other objects away from the scissor points under the seats. Failure to do so could cause personal injury.

The following is a description of adjustments that can be made to various Western Star seats. Not all seats have all of the adjustments listed below. See [Fig. 4.28](#).

- **Isolator:** This feature reduces the amount of road shock by isolating the occupant from the motion of the vehicle, and allowing the upper seat to move in a simple pendulum motion. A lockout feature is used whenever the isolator is not desired.
 - **Height Adjustment:** This adjustment moves the entire seat up or down. The adjustment is either manually- or air-controlled, depending on the make of the seat.
 - **Bottom Cushion Angle (fore-and-aft bottom cushion height):** This adjustment enables the occupant to raise or lower the front or back of the bottom cushion. This adjustment is easier to perform when all weight is removed from the seat.
 - **Fore-and-Aft Seat Slide (seat track adjustment):** This adjustment moves the entire seat forward or backward on its track.
 - **Seat Tilt:** This adjustment allows the seat assembly (back and bottom cushions) to tilt forward or backward.
 - **Headrest Adjustment:** This adjustment changes the angle of the upper part of the backrest to provide head and upper back support.
- **Backrest Tilt:** This adjustment enables the backrest to pivot forward or backward.
 - **Lumbar Support:** Lumbar support changes the shape of the backrest to give more or less support to the occupant's lumbar (lower back) area. This adjustment is either mechanical or air controlled, depending on make and model of the seat.

Driver Controls

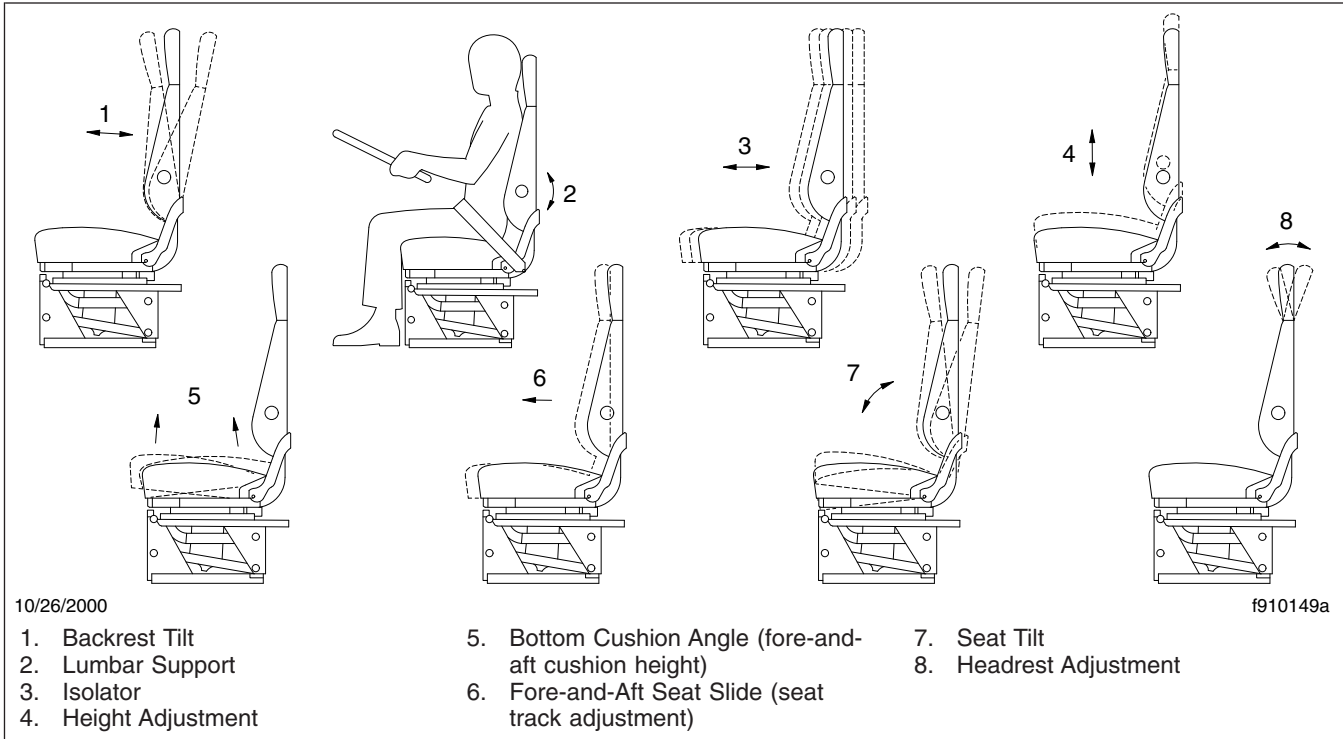

Fig. 4.28, General Seat Adjustments

5

Climate Controls

Climate Control Options	5.1
Cab Climate Control Panels	5.1
Sleeper Climate Control Panels	5.4

Climate Controls

Climate Control Options

The climate control panel allows you to control the heating, ventilating, defrosting, and air conditioning functions. Western Star vehicles have several heater and air conditioner options.

Options for the cab include:

- heater only
- heater and air conditioner
- heater and air conditioner with automatic temperature control (ATC)

Options for a sleeper unit include:

- no heater or air conditioner
- heater only
- heater and air conditioner
- heater and air conditioner with ATC

The ATC feature automatically controls the heating and cooling system to maintain the cab and sleeper air temperature close to the temperature set by the user. The ATC adjusts the air temperature blown through the air outlets to maintain the selected temperature.

Cab Climate Control Panels

The standard cab climate control panel has a fan switch, a temperature control switch, and a mode control switch that allows the driver to control heating, cooling, defrosting, and ventilating. The control panel may also be equipped with an optional A/C switch and/or an optional BUNK switch. See [Fig. 5.1](#).

Vehicles equipped with ATC have an LED display. See [Fig. 5.2](#).

Controls

Fan Switch

The fan switch activates the fan, which forces fresh air or recirculated air through the air outlets. The fan switch has four fan speed settings and an off position. See [Fig. 5.1](#).

To operate the fan switch, turn the fan switch clockwise to increase airflow; turn the fan switch counterclockwise to decrease airflow.

On vehicles equipped with ATC, the AUTO setting on the fan switch places the heater and air conditioner system in the automatic fan speed control mode. When the fan switch is set to AUTO, the fan speed will vary as necessary to maintain the temperature set by the user.

Temperature Control Switch

To select the desired temperature:

- *Vehicles Without ATC:* Turn the switch to the left (counterclockwise) for cool air, or to the right (clockwise) for hot air.
- *Vehicles With ATC:* Press and release the right side of the temperature up/down switch to increase the temperature to the desired setting. Press and release the left side of the temperature up/down switch to decrease the temperature to the desired setting. Press and hold the temperature up/down switch to change the desired temperature in large increments.

Mode Control Switch

The mode control switch allows the driver to control the flow of air through the face outlets, the floor outlets, the defrost (windshield) outlets, or a combination of these outlets to provide six air selection modes. See [Fig. 5.3](#).

- *Face Mode (using recirculating air):* Directs all airflow through the face or instrument panel outlets, using recirculated air.
- *Face Mode (using fresh air):* Directs all airflow through the face or instrument panel outlets, using fresh air.
- *Bi-Level Mode:* Directs the airflow equally to the face outlets and the floor outlets.
- *Floor Mode:* Directs all airflow through the floor outlets.
- *Floor/Defrost Mode:* Directs the airflow equally to the floor outlets and the defrost outlets.
- *Defrost Mode:* Directs all airflow through the defrost outlets.

NOTE: The face mode using recirculating air is the only mode that recirculates the air in the cab. All other modes draw in fresh air from outside the vehicle.

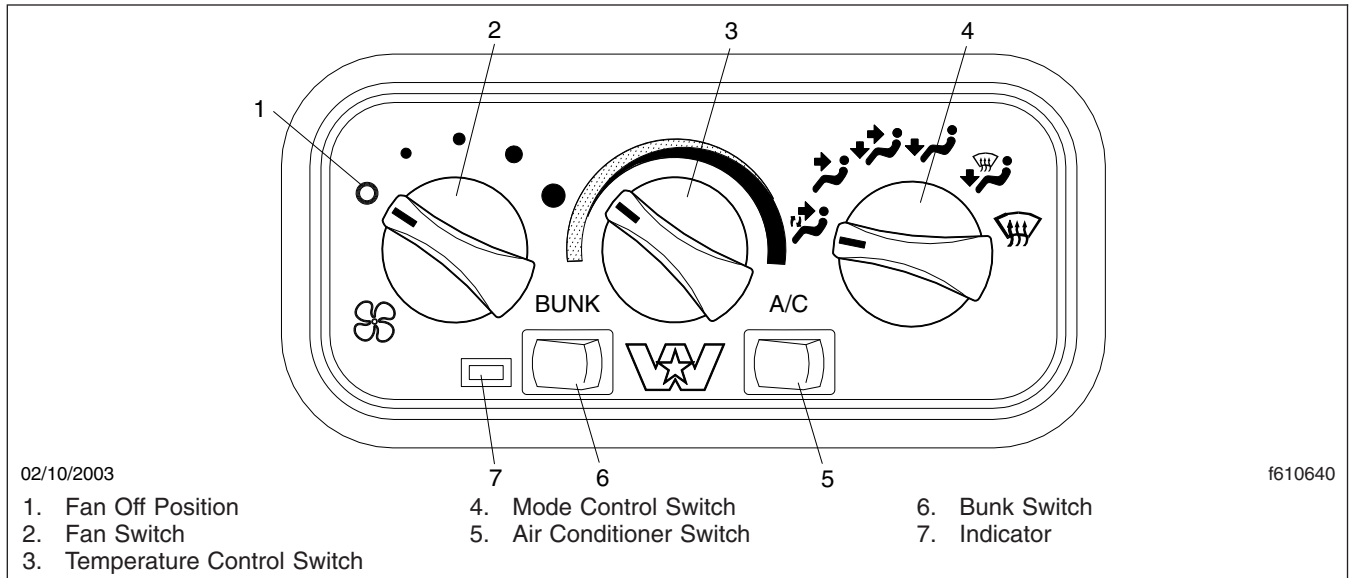

Fig. 5.1, Cab Climate Control Panel, No ATC

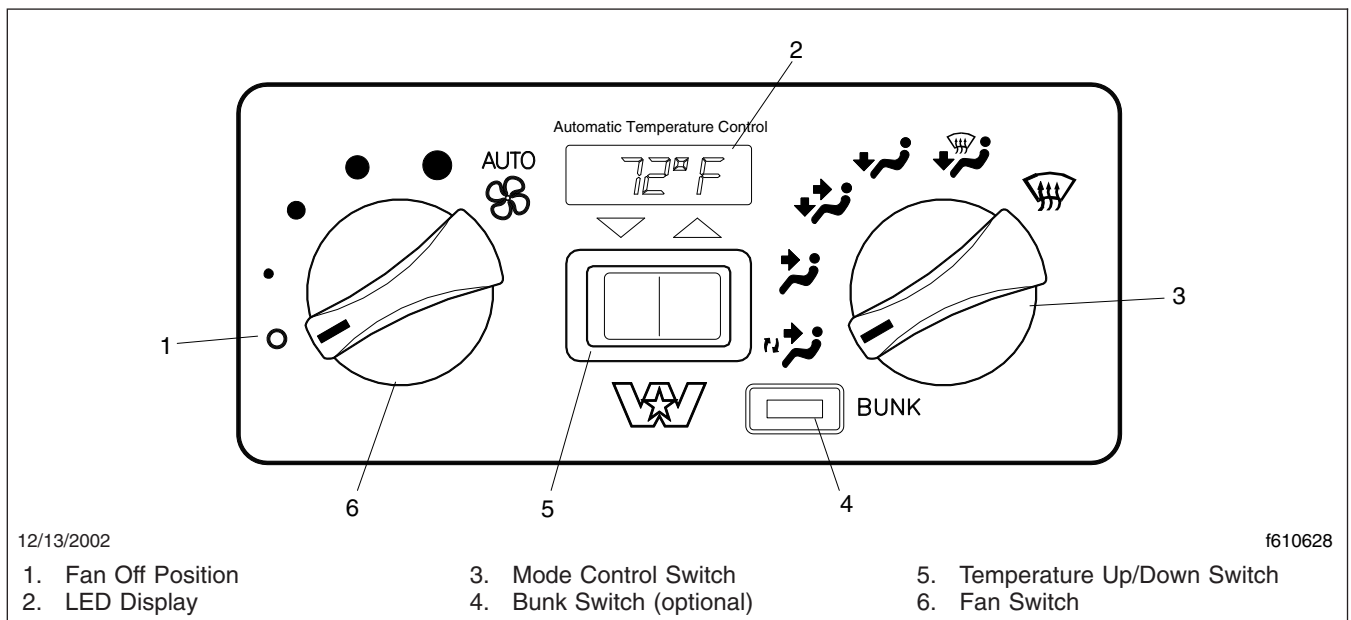

Fig. 5.2, Cab Climate Control Panel With ATC

Bunk Switch

The optional BUNK switch allows the driver to control the sleeper heater and air conditioner from the cab. Press the BUNK switch to turn the sleeper heater and air conditioner on. When the bunk switch is on, the indicator light is on. The sleeper heater and air

conditioner can still be controlled from the sleeper when the BUNK switch is on.

Air Conditioner (A/C) Switch

The air conditioner cools and dehumidifies the air inside the cab. Press the optional A/C switch to turn

Climate Controls

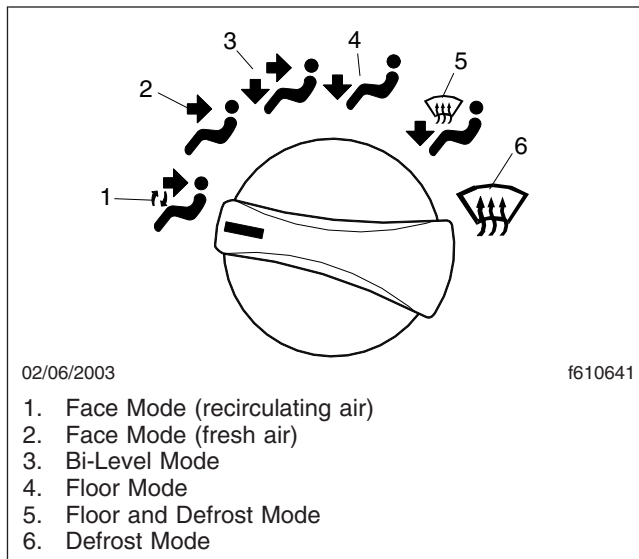

Fig. 5.3, Mode Control Switch Settings

the air conditioner on or off. When the air conditioner is on, the A/C switch illuminates.

IMPORTANT: Operate the air conditioner at least five minutes each month, even during cool weather. This helps prevent drying and cracking of the refrigerant compressor seals and reduces the chance of refrigerant leaks in the system.

LED Display, Vehicles With ATC Only

The LED display shows the temperature to which the heater or air conditioner has been set in degrees Fahrenheit or degrees Celsius.

Changing Temperature Units

The temperature units can be changed from Fahrenheit (°F) to Celsius (°C) or from Celsius to Fahrenheit by turning the ignition on, turning the fan switch off, and pressing and holding the left side of the temperature up/down switch for five seconds. The current temperature unit will then be shown on the LED display. Press the left side of the temperature up/down switch again to toggle between °F and °C. Changing the temperature units on the cab climate control panel will also effect the sleeper climate control panel.

Error Codes

Error codes can be displayed by turning the ignition on, turning the fan switch off, and pressing and hold-

ing the right side of the temperature up/down switch for five seconds. The current error status will be shown on the LED display. Press the right side of the temperature up/down switch again repeatedly to scroll the display through any existing error codes. If an error code is displayed, contact your Western Star dealer for service.

Modes

Recirculation Mode



Do not use the recirculation mode when the heater is on and the vehicle is in motion. Driving with the recirculation mode on while the heater is on may cause the windows to be obscured by moisture or ice, which could result in an accident possibly causing personal injury or property damage.

Do not use the recirculation mode for more than 20 minutes at a time because the air inside the cab may become stuffy and the windows may become obscured by moisture, which could result in an accident possibly causing personal injury or property damage.

When the mode control switch (see Fig. 5.3) is turned to the face mode using recirculating air, the air in the cab is recirculated through the heater and air conditioner system. This is the only mode that uses recirculated air. Fresh air, or outside air, is circulated through the heating and air conditioning system when any other mode is selected.

The recirculation mode can be used to prevent dusty or smoky air from entering the cab, or to decrease the time required to cool or heat the cab interior during extreme outside temperature conditions. When the outside air is clear or the desired cab temperature is reached, change the mode control switch to a fresh-air mode. The recirculation mode can be used when the air conditioner is on whether the vehicle is moving or not.

Defrost Mode

The defrost mode is used to deice, defrost, or defog the windows.

NOTE: When the defrost mode is on, the air conditioner is on. The air conditioner is used to

dehumidify the air entering the cab and to remove the moisture from the windshield.

Sleeper Climate Control Panels

The standard sleeper climate control panel has a fan switch, a temperature control switch, and a power switch that allow you to control the heating and air conditioning functions in the sleeper. A vehicle with an air conditioner has an air conditioner switch on the control panel. See [Fig. 5.4](#).

Vehicles with ATC have button controls instead of switch controls. See [Fig. 5.5](#).

Controls, Vehicles Without ATC

Power Switch and Indicator

The power switch is used to turn the sleeper heater and air conditioner on and off. When the heater or air conditioner is on, the indicator illuminates.

Fan Switch

The fan switch controls the fan speed and forces air through the air outlets. The fan switch has three speed settings and an off position. See [Fig. 5.4](#).

To operate the fan switch, turn the switch clockwise to increase airflow; turn the fan switch counterclockwise to decrease airflow.

Temperature Control Switch

To select the desired temperature, turn the switch to the left (counterclockwise) for cool air, or to the right (clockwise) for hot air.

Air Conditioner (A/C) Switch

The air conditioner cools and dehumidifies the air inside the sleeper. Press the optional A/C switch to turn the air conditioner on or off.

Controls, Vehicles With ATC

The controls for the sleeper heater and air conditioner are located on the right side of the ATC sleeper control panel. See [Fig. 5.5](#).

Power Switch and Indicator

Turn the sleeper heater and air conditioner on by pressing the ON button. The current set temperature is displayed for five seconds, after which it returns to the time display. When the heater or air conditioner is on, the indicator illuminates. To turn the sleeper heater and air conditioner off, press the OFF button.

Fan Switch

To operate the fan switch, press the fan up or fan down button repeatedly to incrementally increase or decrease the fan speed. Press either button for at

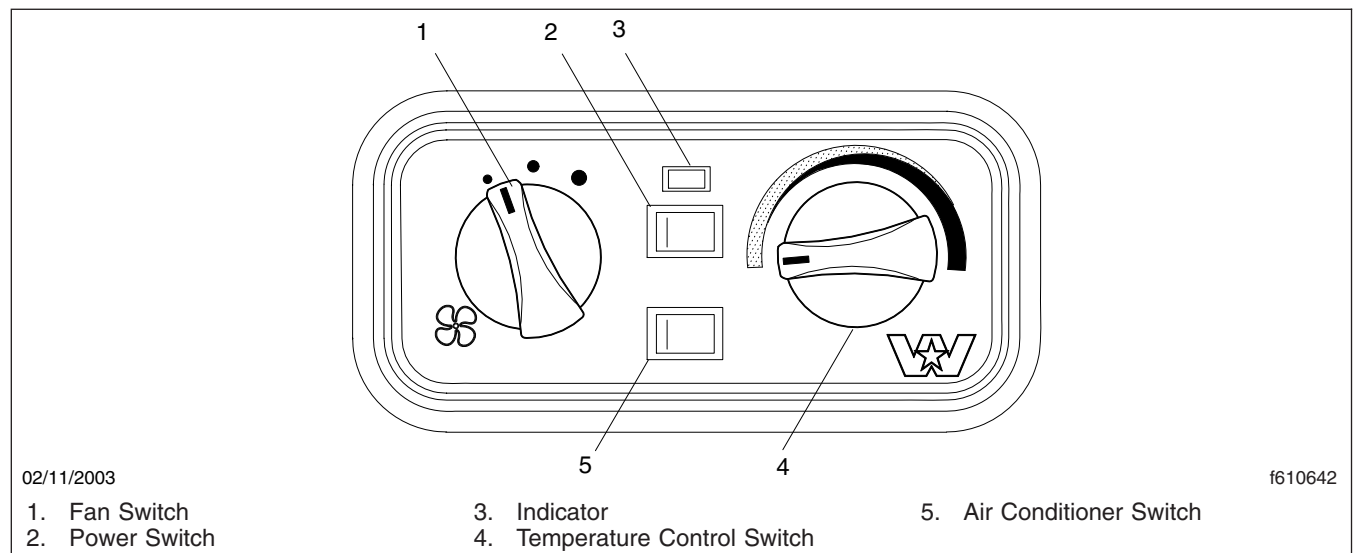

Fig. 5.4, Sleeper Climate Control Panel, No ATC

Climate Controls

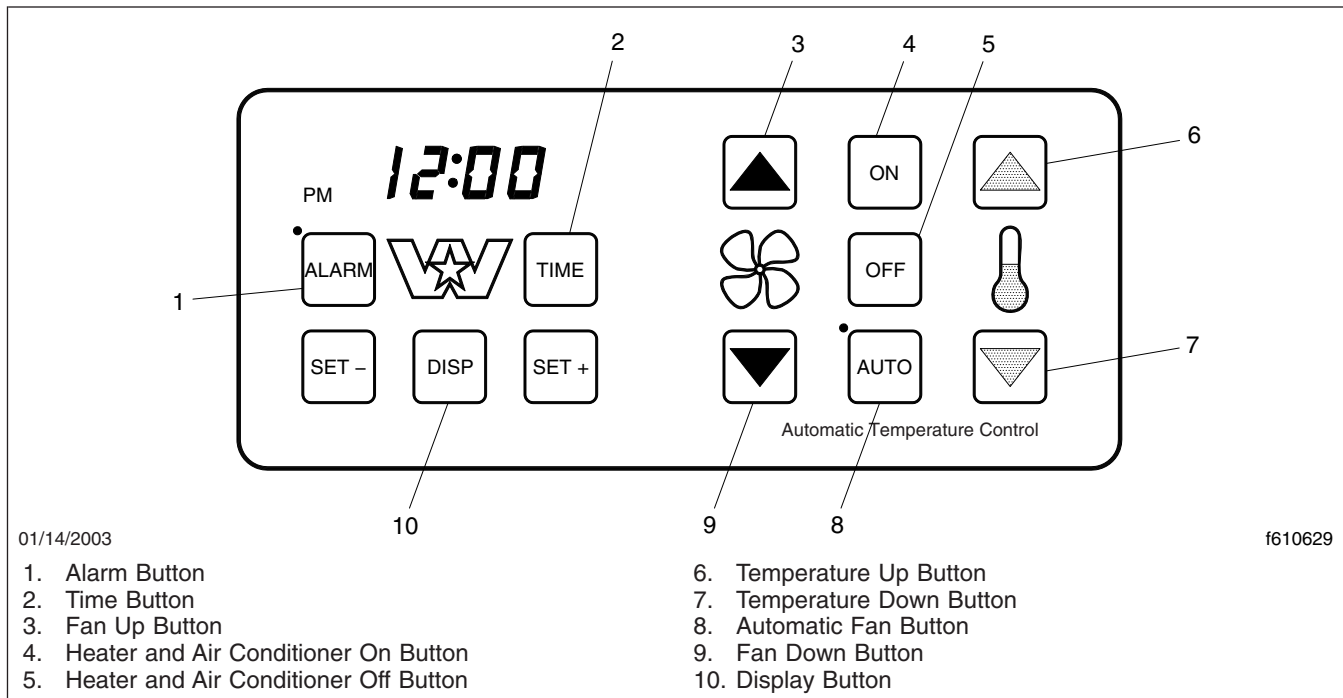

Fig. 5.5, Sleeper Climate Control Panel With ATC

least two seconds to continuously increase or decrease the fan speed. The fan speed setting is displayed on the sleeper control panel in 10 percent increments. When the highest or lowest fan speed is selected, HI or LO is displayed. The display returns to the time display five seconds after a fan up/down button is pressed and released.

In the ATC mode, fan speed is determined by the system as required. The fan speed is based on the difference between the set point temperature and the actual sleeper cab temperature. The greater the difference, the greater the fan speed. The AUTO fan function is disabled when either the fan up or fan down button is pressed.

Temperature Control Switch

Temperature is displayed with a three-digit annotation and can be displayed either in degrees Celsius or degrees Fahrenheit. A capital "C" or "F" is displayed for the appropriate temperature scale.

To select the desired temperature, press the temperature up or temperature down button repeatedly to incrementally increase or decrease the set temperature. Press either button for at least two seconds to continuously increase or decrease the set tem-

perature. The temperature setting is displayed on the sleeper control panel. The display returns to the time display five seconds after a temperature up/down button is pressed and released.

The temperature units can be changed from °F to °C or from °C to °F by pressing the temperature up and temperature down buttons simultaneously. Changing the temperature units on the ATC sleeper control panel will also change the temperature units on the ATC cab control panel.

Auto Button

Press the AUTO button to enable automatic control of the fan speed. The display will show the current set temperature for five seconds, then return to the time display. When in the automatic mode, the fan speed can vary to maintain the temperature set by the user. When automatic control is turned on, the indicator above the AUTO button illuminates.

Alarm Button

Momentarily press the ALARM button to turn the alarm on and to illuminate the alarm indicator above the ALARM button. Momentarily press the button again to deactivate the alarm.

When pressing the ALARM button, the display shows the alarm time setting for five seconds before returning to the current time display. If the ALARM button is pressed and held down continuously for more than one second, the alarm time setting can be viewed without changing the state of the alarm indicator. If either the SET+ or SET- buttons are pressed simultaneously with the ALARM button held down, the alarm time setting will increase or decrease. When the ALARM button is released after changing the alarm time, the alarm will be turned on and the indicator will be illuminated. When the ALARM is sounding, press the ALARM button to turn the alarm off and to reset the alarm for the next 24-hour cycle.

To set the snooze function, press any button on the control panel, except the ALARM button, when the alarm is sounding. The alarm will sound again after seven minutes. The alarm indicator flashes when the snooze function is set.

To cancel the snooze function, press the ALARM button. This will also reset the alarm for the next 24-hour cycle.

Time Button

The clock controls are located on the left side of the ATC sleeper control panel under the display. The display will show the clock time as the default mode.

Press the TIME button to display the current time. If the TIME button is held down and either the SET+ or SET- buttons are pressed simultaneously with the TIME button, the clock setting will increase or decrease.

Display Button

Press the DISP button to allow the display and illumination of the control panel to scroll through three illumination levels: bright, dim, and off. If you want the alarm, time, or temperature setting to be displayed when the display is in the off mode, press the ALARM, TIME, or temperature up/down buttons to display the corresponding display for five seconds. After five seconds, the display will turn off. If the alarm sounds while in the display off mode, the current time will be displayed simultaneously. The display will remain on for five minutes, then turn off.

When the vehicle ignition is not powered, the sleeper climate control panel is in a power-saving mode and the display and illumination of the control panel will

be off. All clock functions, including the alarm, will continue to work internally.

Temperature Slave Mode Feature

The temperature slave mode allows the set temperature of the cab heater and air conditioner to be automatically tied to the sleeper heater and air conditioner. In this mode, the set temperature in the vehicle will be the same whether the set temperature is changed on the cab climate control panel or the sleeper climate control panel. To enable the temperature slave mode, press the SET+ and SET- buttons simultaneously. The display will read S-ON when the temperature slave mode is enabled.

To disable the temperature slave mode, press the SET+ and SET- buttons simultaneously. The display will read S-OFF indicating that the temperature slave mode is disabled. When disabled, the temperatures for the cab and sleeper can be changed independently for separate temperature control. If you wish to maintain a temperature in the sleeper that is different than the temperature in the front of the cab, it is recommended that a curtain be used between the sleeper and the front of the cab.

Turning on the Sleeper Air Conditioner When the Cab Air Conditioner is Off

The sleeper ATC control panel can turn on the air conditioner even if the cab HVAC unit is turned off but the engine is running. By pressing the ON button, the ATC sleeper control panel will turn on the cab unit and the bunk indicator light on the cab control panel will be illuminated. If cooling is needed in the sleeper, the cab HVAC unit will switch on to a low blower fan setting and the A/C compressor clutch will engage. If cooling is no longer required in the sleeper or if heat is needed, the cab unit fan and the compressor clutch will be turned off after a five-minute delay.

Accessory Heaters

Optional accessory heaters are available from the factory in several configurations. Familiarize yourself with the equipment on your specific vehicle, and follow the manufacturer's operating and maintenance instructions.

Climate Controls

 WARNING
--

Do not operate fuel-operated heaters in an area where flammable vapors, including gasoline or diesel fumes, are present, such as at filling stations and tank farms. Turn off a fuel-operated heater and allow it shut down completely before entering an area where flammable gases or liquids are present. Heaters continue to operate for up to three minutes after being turned off.

Failure to observe these precautions could cause an explosion or fire, resulting in serious property damage, and personal injury or death.

6

Seats and Restraints

Seats, General Information	6.1
Western Star High-Back Seat	6.2
Bostrom Seat	6.3
National Seat	6.4
ABTS Seat	6.4
Seat Belts and Tether Belts	6.5
Sleeper Compartment Restraints	6.9

Seats and Restraints

Seats, General Information

Unless otherwise noted, all seat adjustments should be made while seated and before the engine is started.

Due to the high degree of adjustability of mid- and high-back air suspension seats, it is possible to combine the seat back recline adjustment and the seat slide adjustment so that the seat back contacts the back wall. Use care when adjusting the seat to prevent damage to the seat and the cab interior.

WARNING

Keep hands, tools, and other objects away from the scissor points under the seats. Failure to do so could cause personal injury.

The following is a description of adjustments that can be made to various Western Star seats. Not all seats have all of the adjustments listed below. See [Fig. 6.1](#).

- *Backrest Tilt* enables the backrest to pivot forward or backward.

- *Lumbar Support* changes the shape of the backrest to give more or less support to the occupant's lumbar (lower back) area. This adjustment is either mechanical or air controlled, depending on the seat model.
- *Isolator* feature reduces the amount of road shock by isolating the occupant from the motion of the vehicle, and allowing the upper seat to move in a simple pendulum motion. A lock-out feature is used whenever the isolator is not desired.
- *Height Adjustment* moves the entire seat up or down. The adjustment is either manually- or air-controlled, depending on the seat model.
- *Bottom Cushion Angle (fore-and-aft bottom cushion height)* enables the occupant to raise or lower the front or back of the bottom cushion. This adjustment is easier to perform when all weight is removed from the seat.
- *Fore-and-Aft Seat Slide (seat track adjustment)* moves the entire seat forward or backward on its track.

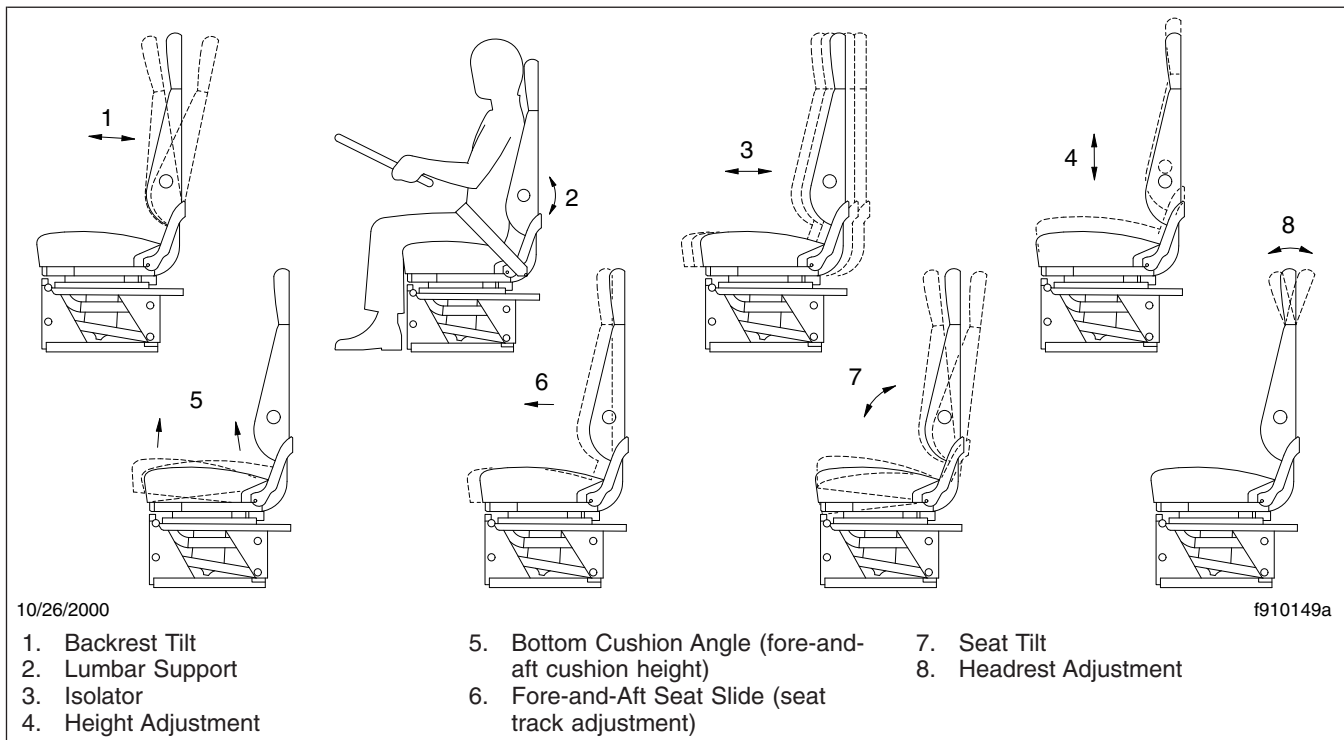

Fig. 6.1, General Seat Adjustments

- *Seat Tilt* allows the seat assembly (back and bottom cushions) to tilt forward or backward.
- *Headrest Adjustment* changes the angle of the upper part of the backrest to provide head and upper back support.

Western Star High-Back Seat

See [Fig. 6.2](#) for seat adjustment controls. Not all models of the seat have all the adjustments listed below.

Backrest Tilt

To tilt the backrest, lean forward slightly to remove pressure from the cushion, then turn the knob forward or rearward to achieve the desired position.

Lumbar Support

To adjust the lumbar support, use the lumbar support switches on the side of the seat.

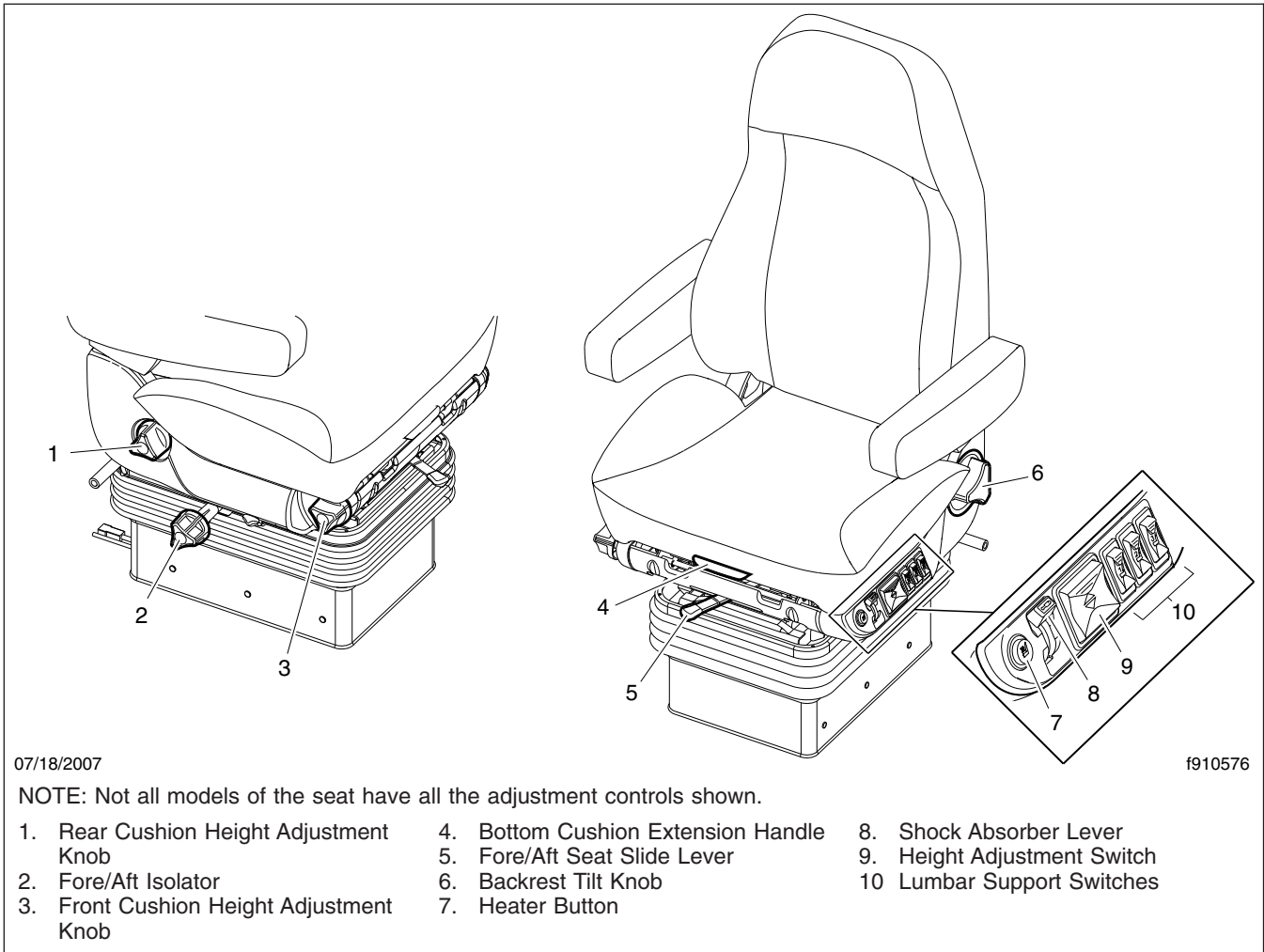

Fig. 6.2, Western Star High-Back Seat

Seats and Restraints

Height Adjustment

To raise or lower the height of the seat, use the height adjustment switch on the side of the seat.

Bottom Cushion Extension

To adjust the fore-and-aft position of the seat cushion, remove your weight from the seat, then lift up and pull forward on the cushion adjustment handle. To return the cushion to the aft position, lift up and push rearward.

Fore/Aft Seat Slide

To adjust the fore-and-aft position of the entire seat, move the fore-and-aft seat adjustment lever to the left and slide the seat forward or backward to the desired position. Move the lever back to its original position to lock the seat in place.

Fore/Aft Isolator

To engage the isolator, turn the isolator knob rearward to the unlocked position. Turn the isolator knob forward to the locked position when the isolator feature is not desired.

Shock Absorber

To adjust the amount of damping the shock absorber provides, move the lever up to increase damping; move the lever down to decrease damping.

Front Cushion Height

To adjust the height of the front of the cushion, remove your weight from the seat, then turn the adjustment knob toward the front of the seat (clockwise) to increase cushion height. To lower the cushion height, turn the adjustment knob toward the rear of the seat (counterclockwise).

Rear Cushion Height

To adjust the height of the rear of the seat cushion, remove your weight from the seat and turn the rear cushion adjustment knob to one of three positions.

Heater

To turn on the heat option, press the button. To turn off the heat option, press the button again. If the vehicle has Optimized Idle, seat heating will not oper-

ate with the key in accessory mode. Optimized Idle may also turn seat heating off to reduce stress on the batteries.

Bostrom Seat

See [Fig. 6.3](#) for Bostrom seat adjustment controls.

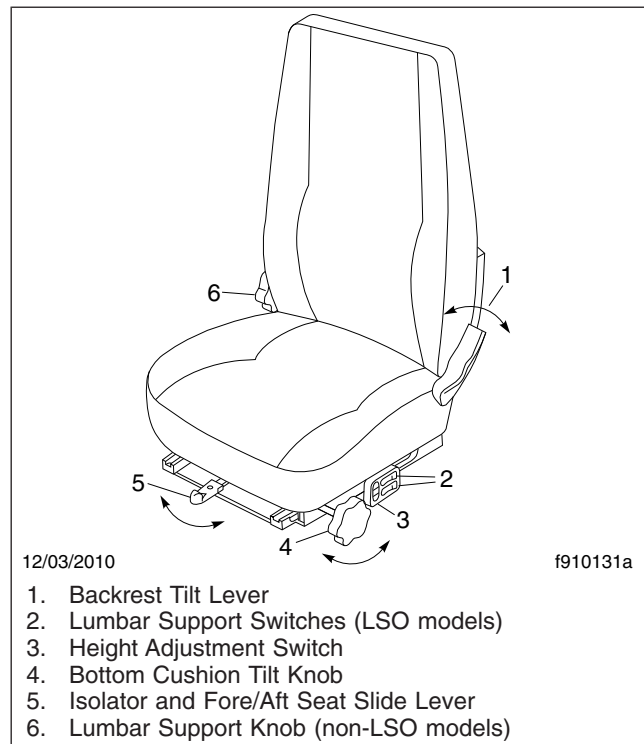

Fig. 6.3, Bostrom Seat Adjustment Controls

Backrest Tilt

To tilt the backrest, lean forward slightly to remove pressure from the cushion and hold the backrest tilt lever rearward. Lean forward or backward slowly to the desired position and release the lever to lock the backrest in place.

Lumbar Support

To increase lumbar support on luxury seat option (LSO) models, press the plus sign on the lumbar support switch. To decrease lumbar support, press the minus sign on the switch.

To increase lumbar support on non-LSO models, rotate the lumbar support knob forward. To decrease lumbar support, rotate the knob rearward.

Height Adjustment

To raise the seat, press the upper portion of the height adjustment switch. To lower the seat, press the lower portion of the switch.

Bottom Cushion Tilt

To adjust the bottom cushion tilt, rotate the bottom cushion tilt knob to increase or decrease tilt.

Fore-and-Aft Seat Slide

To adjust the fore-and-aft position of the entire seat, hold the fore-and-aft adjustment lever to the left and slide the seat forward or backward to the desired position.

Isolator

To engage the isolator, put the isolator lever in the center position. Lock out the isolator by moving the lever to the right.

National Seat

See [Fig. 6.4](#) for National seat adjustment controls.

Backrest Tilt

To tilt the backrest, turn the backrest tilt knob until the desired position is reached.

Lumbar Support

To adjust the lumbar support, use the lumbar support switch on the side of the seat.

Height Adjustment

To raise or lower the height of the seat, use the height adjustment switch on the side of the seat.

Bottom Cushion Fore-and-Aft Slide

To adjust the bottom cushion, lift the bottom cushion adjustment handle and pull forward or push back to the desired setting.

Fore-and-Aft Seat Slide

To adjust the fore-and-aft position of the entire seat, move the fore-and-aft seat adjustment lever to the left and slide the seat forward or backward to the

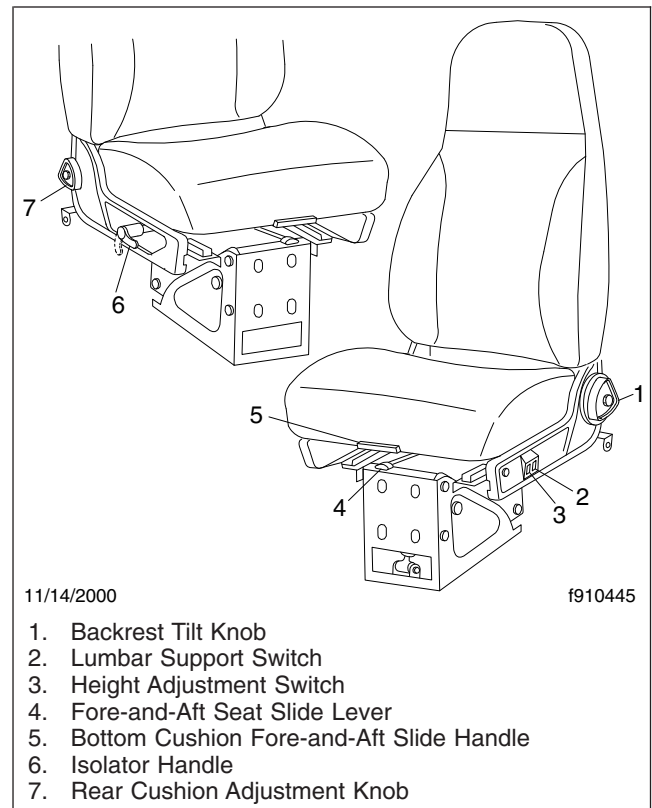

Fig. 6.4, National 2000 Series Seat Adjustment Controls

desired position. Move the lever back to its original position to lock the seat in place.

Isolator

To engage the isolator, turn the isolator lever to the horizontal position. Lock out the isolator by turning the isolator lever down.

Rear Cushion Adjustment

To adjust the height of the rear of the seat cushion, remove your weight from the seat and turn the rear cushion adjustment knob to one of three positions.

ABTS Seat

See [Fig. 6.5](#) for ABTS (all-belts-to-seat) seat adjustment controls.

Seats and Restraints

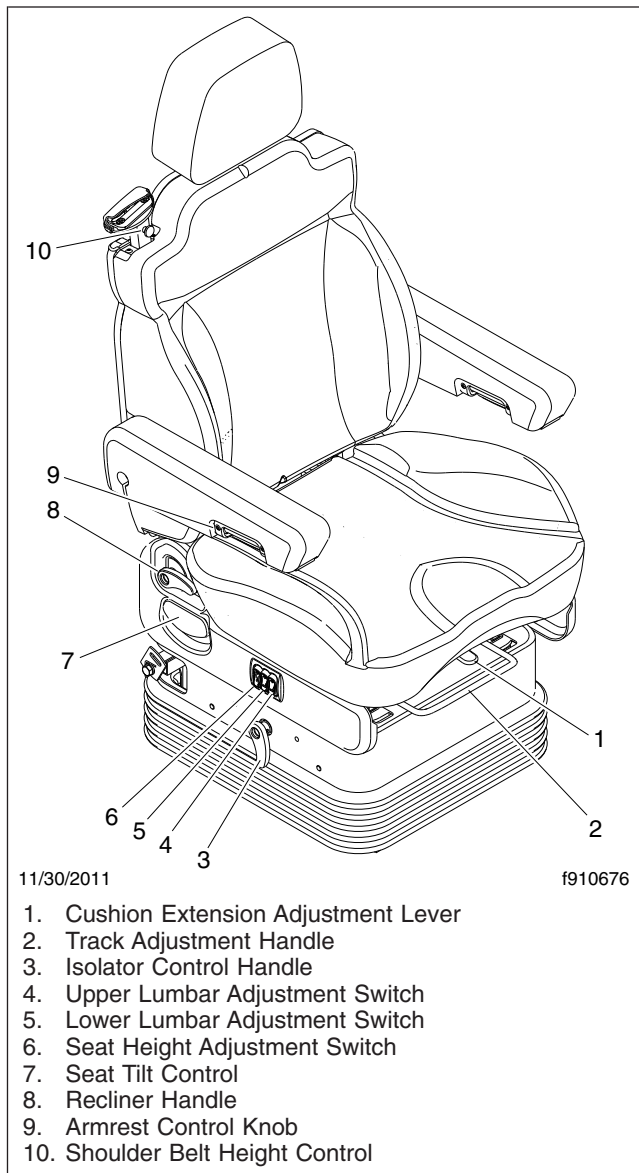

Fig. 6.5, ABTS Seat Adjustment Controls

Cushion Extension Adjustment

Move the cushion extension adjustment lever to the left and move the seat cushion to the desired position.

Track Adjustment

To adjust the fore-and-aft position of the entire seat, lift the track adjustment handle and slide the seat to the desired position.

Isolator

Pull up the isolator control handle to lock out the isolation movement.

Lumbar Adjustment

Push the middle rocker switch to adjust the lower lumbar bag. Push the forward switch to adjust the upper lumbar bag.

Seat Height Adjustment

Push the seat height adjustment switch to raise or lower the seat suspension.

Seat Tilt Control

Set the seat tilt control to one of the five positions to set cushion rake adjustment.

Backrest Adjustment

To tilt the backrest backward, pull up on the recliner handle while leaning backward. To tilt the backrest forward, pull up on the recliner handle while leaning forward.

Armrest Adjustment

Rotate the control knob, located on the underside of the armrest, to set the desired angle of the armrest.

Shoulder Belt Height Control

Adjust the shoulder belt height. The height can be adjusted vertically by 3 inches (75 mm).

Seat Belts and Tether Belts

Seat belt assemblies are designed to secure persons in the vehicle to help reduce the chance of injury or the amount of injury resulting from accidents or sudden stops. For this reason, Daimler Trucks North America LLC (DTNA) urges that the driver and *all* passengers, regardless of age or physical condition, use seat belts when riding in the vehicle.

WARNING

Always use the vehicle's seat belt system when operating the vehicle. Failure to do so can result in severe personal injury or death.

Seat belt assemblies in DTNA vehicles meet Federal Motor Vehicle Safety Standard 209, "Type 1" and "Type 2" requirements.

When transporting a child, always use a child restraint system or the vehicle seat belts as appropriate. To determine whether a child restraint system is required, review and comply with applicable state and local laws. Any child restraint used must comply with Federal Motor Vehicle Safety Standard 213, "Child Restraint Systems." When providing a child restraint system, always carefully read and follow all instructions pertaining to installation and usage for the child. Make certain the child remains in the restraint system at all times when the vehicle is in motion.

In addition to seat belt assemblies, tether belts are installed on suspension-type seats. Tether belts help secure the seat to the floor and are intended to restrain the seat and seat belt in case of an accident or sudden stop.

IMPORTANT: Seat belts have a finite life which may be much shorter than the life of the vehicle. Regular inspections and replacement as needed are the only assurance of adequate seat belt security over the life of the vehicle.

Seat Belt Inspection

WARNING

Inspect and maintain seat belts. When any part of a seat belt system needs replacement, the entire seat belt must be replaced, both retractor and buckle side. Any time a vehicle is involved in an accident, and the seat belt system was in use, the entire vehicle seat belt system must be replaced before operating the vehicle. Do not attempt to modify the seat belt system; doing so could change the effectiveness of the system. Failure to replace worn or damaged seat belts, or making any modifications to the system, may result in personal injury or death.

Inspect the seat belts and tether belts (if so equipped).

1. Check the web for fraying, cuts, extreme dirt and dust, or for severe fading from exposure to sunlight, especially near the buckle latch plate and in the D-loop guide area.
2. Check operation of the buckle, latch, Komfort Latch or Sliding Komfort Latch (if equipped), web retractor, and upper seat belt mount on the door pillar. Check all visible components for wear or damage.
3. Check the seat belt and tether belt connection points and tighten any that are loose.

Seat Belt Operation

Seat Belt With Komfort Latch or Sliding Komfort Latch

NOTE: For vehicles not equipped with the Komfort Latch or the Sliding Komfort Latch, see the seat belt operation under the heading **Three-Point Seat Belt**.

WARNING

Wear three-point seat belts only as described below. Three-point seat belts are designed to be worn by one person at a time. In case of an accident or sudden stop, personal injury or death could result from misuse.

Fasten the seat belts before driving. Fastening a three-point seat belt while driving creates a hazard.

When engaged and used properly, the Komfort Latch ([Fig. 6.6](#)) and the Sliding Komfort Latch ([Fig. 6.7](#)) introduce a small amount of slack into the seat belt, resulting in a more comfortable ride.

1. Slowly pull the link end of the seat belt out of the retractor and pull it across your lap (from outboard to inboard) far enough to engage the buckle. If the retractor locks too soon, allow the belt to retract slightly, then slowly pull it out again.
2. Fasten the seat belt by pushing the latch into the buckle. Listen for an audible click. See [Fig. 6.8](#).
3. Tug on the seat belt to make sure it is securely fastened. If the buckle unlatches, repeat this

Seats and Restraints

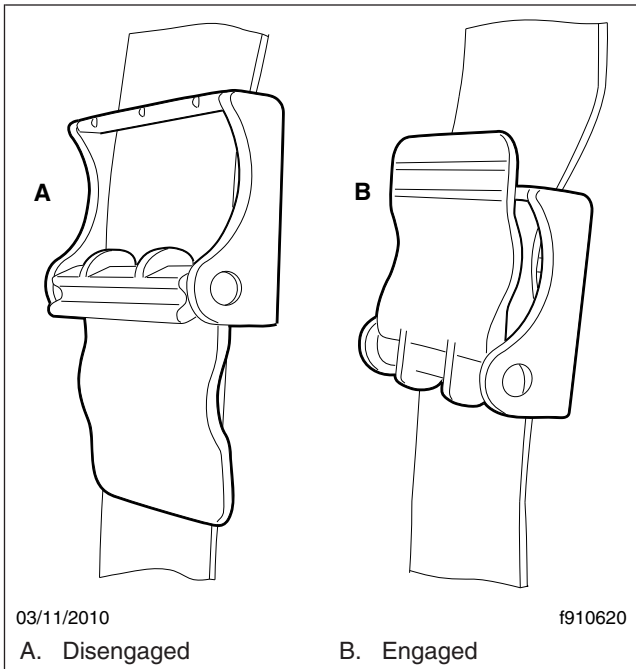

Fig. 6.6, Komfort Latch

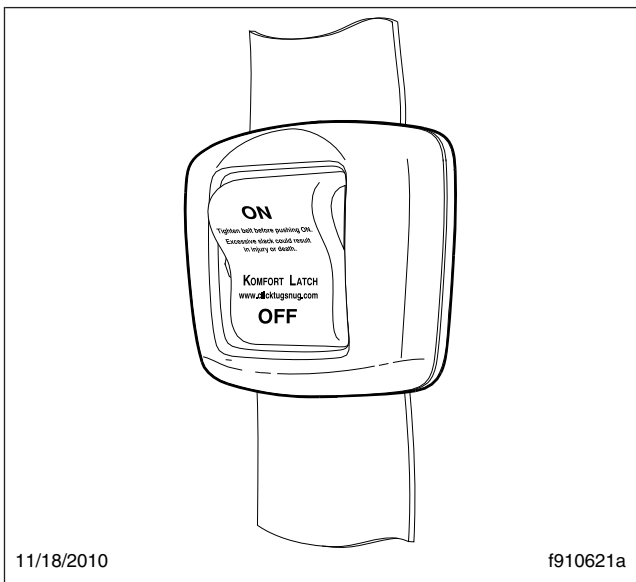

Fig. 6.7, Sliding Komfort Latch

step. If the problem continues, replace the seat belt.

4. Snug the seat belt to your waist.

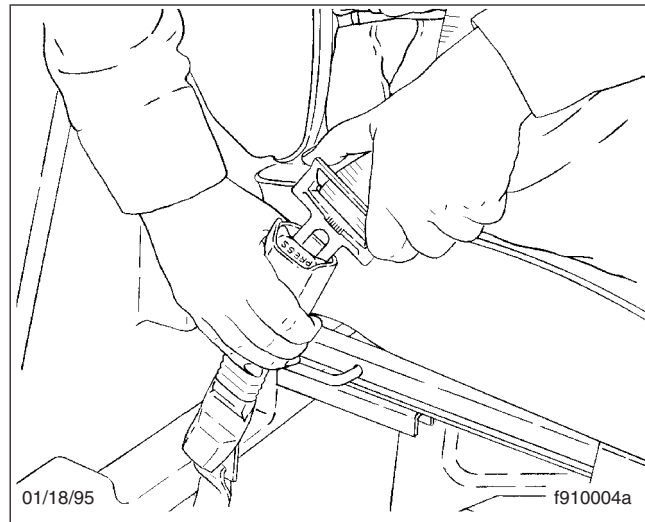

Fig. 6.8, Fastening the Three-Point Belt

WARNING

Before activating the Komfort Latch or the Sliding Komfort Latch, make sure the amount of slack in the shoulder strap is set as described below. Excess slack in the shoulder strap reduces the effectiveness of the seat belt, and increases the risk of injury or death in an accident.

5. Position the shoulder strap diagonally across your chest with the adjustable D-loop bracket (if equipped). The shoulder strap must be centered on your shoulder and chest, away from your face and neck. See Fig. 6.9. If desired, engage the Komfort Latch or Sliding Komfort Latch as follows.

If equipped with a Sliding Komfort Latch, make sure that the shoulder strap is snug against your chest. Without loosening the shoulder strap, push the Sliding Komfort Latch switch to the "ON" position. See Fig. 6.7. To activate the latch lean forward until you hear a click. This will allow for approximately 1 inch (2.5 cm) of slack between your chest and the shoulder harness. Once engaged, the latch will allow you to lean forward about 5 inches (13 cm) without having to reset the latch. Leaning forward more than 5 inches (13 cm) will disengage the Sliding Komfort Latch, requiring it to be reset.

If equipped with a Komfort Latch, pull on the shoulder strap to lessen the pressure of the strap

Seats and Restraints

on your shoulder and chest. Allow no more than 1 inch (2.5 cm) of slack between your chest and the shoulder harness. More slack can significantly reduce the seat belt effectiveness in an accident or a sudden stop. While holding the belt slack, press the Komfort Latch lever up, clamping the seat belt webbing (**Fig. 6.10** and **Fig. 6.11**).

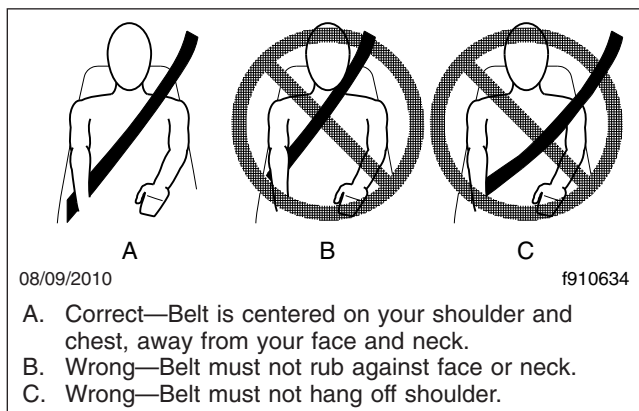

Fig. 6.9, Proper Shoulder Strap Fit

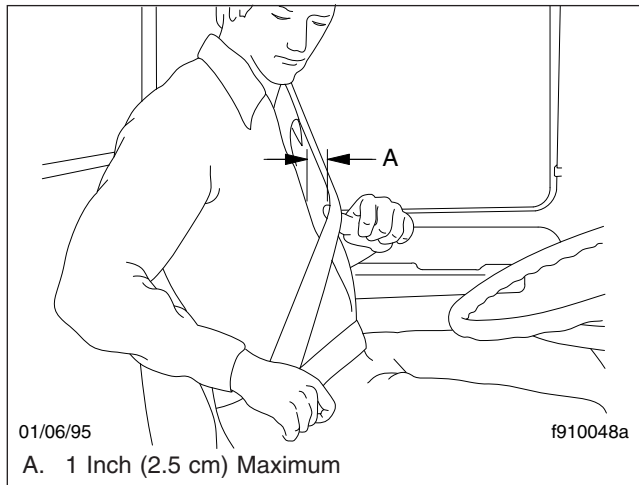

Fig. 6.10, Adjusting Shoulder Harness Clearance, Komfort Latch

- Unbuckle the seat belt and release the Komfort Latch or the Sliding Komfort Latch as follows.
*If equipped with a Sliding Komfort Latch, unbuckle the seat belt (**Fig. 6.12**), then tug on the shoulder belt to release the Sliding Komfort Latch, or press the Sliding Komfort latch to the "OFF" position, then unbuckle the seat belt.*

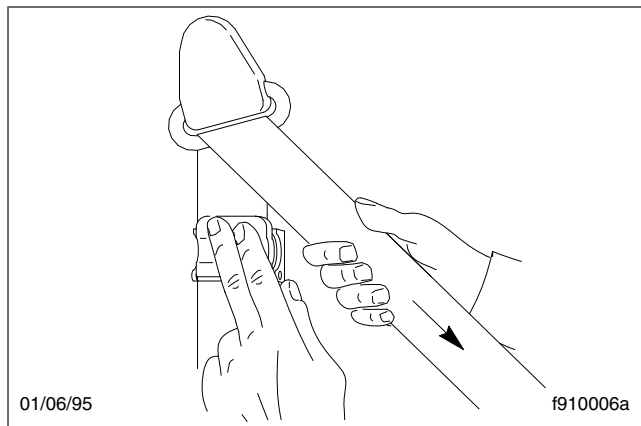

Fig. 6.11, Locking the Komfort Latch

*If equipped with a Komfort Latch, unbuckle the seat belt (**Fig. 6.12**), then release the Komfort Latch by giving the shoulder belt a quick tug. If you lean forward against the shoulder belt, the Komfort Latch will automatically release, and will need to be reset.*

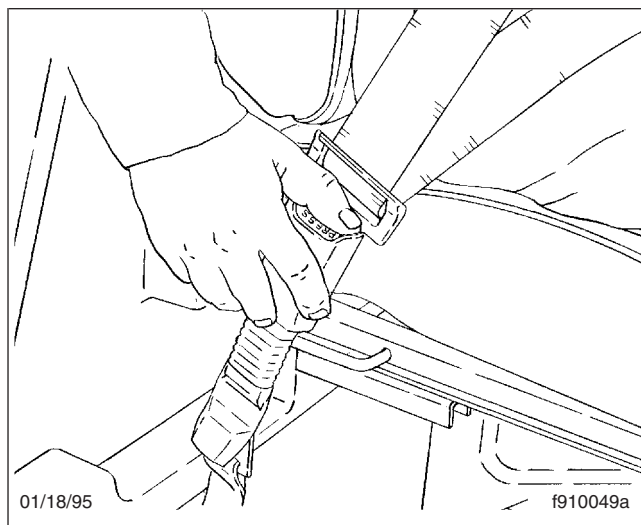

Fig. 6.12, Releasing the Three-Point Seat Belt

NOTE: Neither the Komfort Latch nor the Sliding Komfort Latch need to be manually released in an emergency situation. Each will release by itself under rough road or other abnormal conditions. Make sure the seat belt is completely retracted when it is not in use.

Seats and Restraints

Three-Point Seat Belt

NOTE: For vehicles equipped with the Komfort Latch or the Sliding Komfort Latch, see the seat belt operation under the heading **Seat Belt With Komfort Latch or Sliding Komfort Latch**.

WARNING

Wear three-point seat belts only as described below. Three-point seat belts are designed to be worn by one person at a time. In case of an accident or sudden stop, personal injury or death could result from misuse.

Fasten the seat belts before driving. Fastening a three-point seat belt while driving creates a hazard.

1. Slowly pull the link end of the three-point seat belt out of the retractor and pull it across your lap (from outboard to inboard) far enough to engage the buckle. If the retractor locks too soon, allow the belt to retract slightly, then slowly pull it out again.
2. Fasten the seat belt by pushing the latch into the buckle. Listen for an audible click. See [Fig. 6.8](#).
3. Tug on the seat belt to make sure it is securely fastened. If the buckle unlatches, repeat this step. If the problem continues, replace the seat belt.
4. Snug the seat belt to your waist.
5. Position the shoulder strap diagonally across your chest with the adjustable D-loop bracket (if equipped). The shoulder strap must be centered on your shoulder and chest, away from your face and neck. See [Fig. 6.9](#).
6. To unbuckle the seat belt, press the release button on the buckle. See [Fig. 6.12](#).

NOTE: Make sure the seat belt is completely retracted when it is not in use.

Sleeper Compartment Restraints

WARNING

Do not use the sleeper compartment while the vehicle is in motion unless a bunk restraint is installed and used. Not using the bunk restraint increases the chance of injury, or the degree of injury, from accidents or sudden stops to all occupants of the vehicle.

On vehicles equipped with a sleeper compartment, bunk restraints should be used whenever the sleeper compartment is occupied and the vehicle is moving. Restraints are designed to lessen the chance of injury or the amount of injury resulting from accidents or sudden stops.

Bunk Restraint Adjustment

1. Make sure the belt is attached to the bunk support and sleeper wall.
2. To lengthen the belt, tip the link end downward and pull the link until it connects with the buckle.
3. After the belt is connected, shorten it by pulling on the loose end until the belt is snug, but comfortable. Be sure the belts are not twisted. See [Fig. 6.13](#).

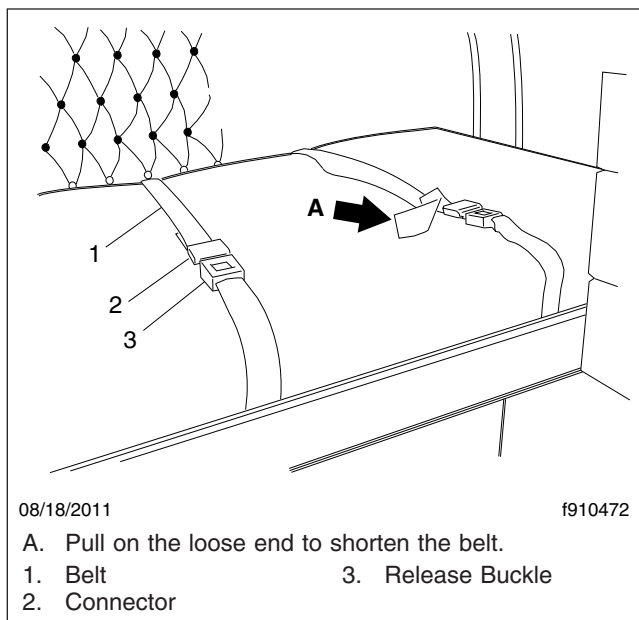

Fig. 6.13, Bunk Restraint Adjustment

7

Cab and Sleeper Features

Windows and Mirrors	7.1
Cab Amenities	7.2
Sleeper Amenities	7.3

Cab and Sleeper Features

Windows and Mirrors

Power Mirrors

The standard outside mirrors are mounted on the door frame. There is a primary rear view mirror and a convex mirror.

Power mirrors are controlled by two switches mounted on the dash control panel. See [Fig. 7.1](#). The switches allow the driver to rotate the mirrors on a horizontal plane.

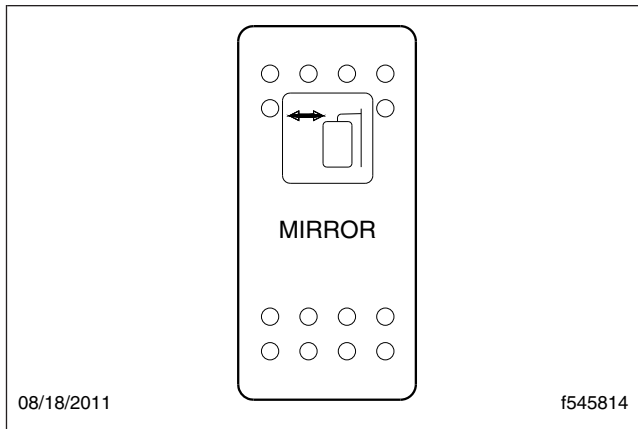

Fig. 7.1, Mirror Control Switch

Optional mirrors may be mounted on the outside of the cab. Cab-mounted mirrors are controlled by switches located in the overhead console.

One or both outside mirrors may be heated to clear fog, frost, or ice.

To defog the mirrors, press the upper half of the mirror defog switch (MIRROR DEFOG). See [Fig. 7.2](#). When the mirror defog switch is on, the status bar illuminates.

Down-View Mirror

An optional down-view mirror may be installed on the door frame to allow the driver a view of the area adjacent to the side of the cab. See [Fig. 7.3](#).

Windows

The windows in both doors are normally operated by window cranks.

Power windows are optional, and may be installed on one or both sides. Power window switches (POWER

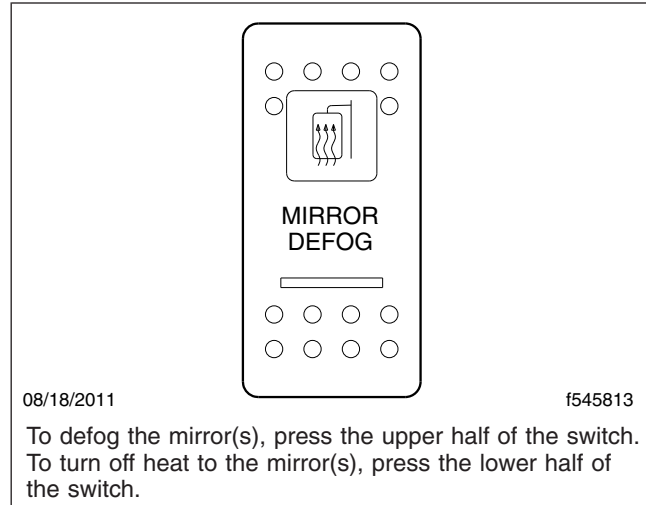

Fig. 7.2, Mirror Defog Switch

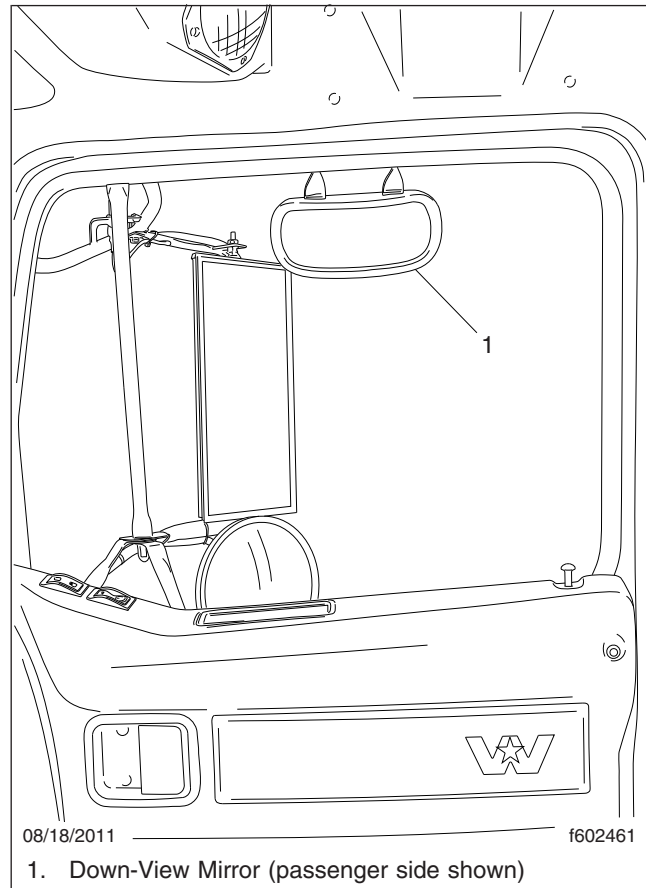

Fig. 7.3, Down-View Mirror

Cab and Sleeper Features

WINDOW) may be located on the door, or on the dash control panel.

To raise the window, press the upper half of the switch. To lower the window, press the lower half of the switch. See **Fig. 7.4**.

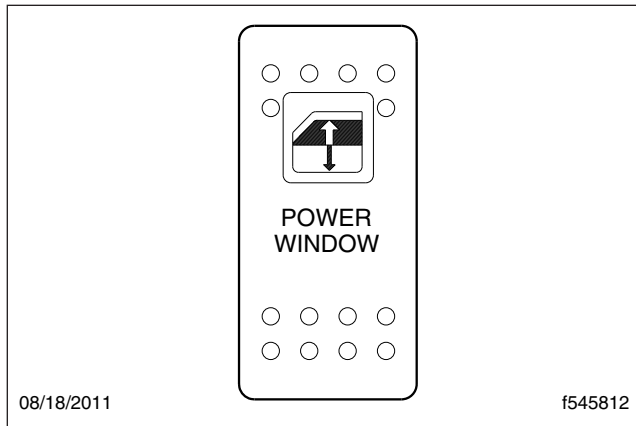

Fig. 7.4, Power Window Switch

Cab Amenities

Western Star vehicles are available with many optional features. The following are some of those options.

Cigar Lighter/Accessory Plug

The cigar lighter/accessory plug (**Fig. 7.5**) is located on the lower right-hand dash panel, above the ignition switch. The ash tray is located to the left of the cigar lighter.

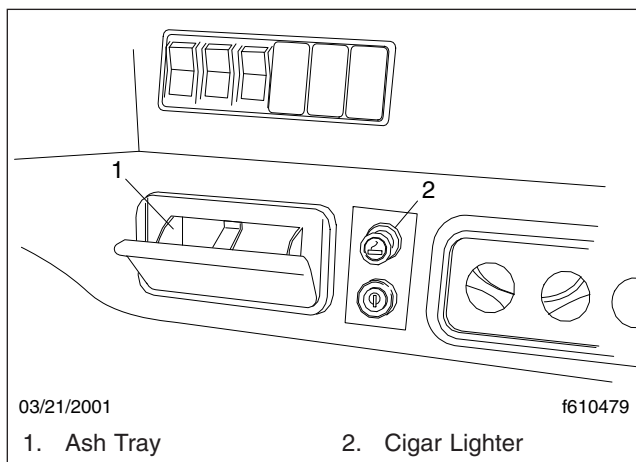

Fig. 7.5, Ash Tray and Lighter

To activate the cigar lighter, push in the element knob. It will pop out when heated. Grasp the element knob and pull it out of the socket.

To remove the ash tray, push down on the center bar, and swing outwards. To install the ash tray, insert in the opening then swing upwards until the bar snaps into place.

Cup Holders

Single and dual cup holders are optional, and are located below the right-hand dash control panel.

Glove Box

The glove box (**Fig. 7.6**) is located on the right side of the dash face, and is equipped with a lock. To lock the latch, insert the key in the lock, and turn it ½-turn clockwise. Remove the key. To unlock the latch, insert the key in the lock, and turn it ½-turn counter-clockwise.

The glove box door is hinged at the bottom. To open the unlocked door, push the button in with your thumb and pull gently on the tang-style latch. The door will swing downwards, then stop in the open position. To close the door, swing it upwards, and put gentle pressure on the latch. The door will be secured, but not locked.

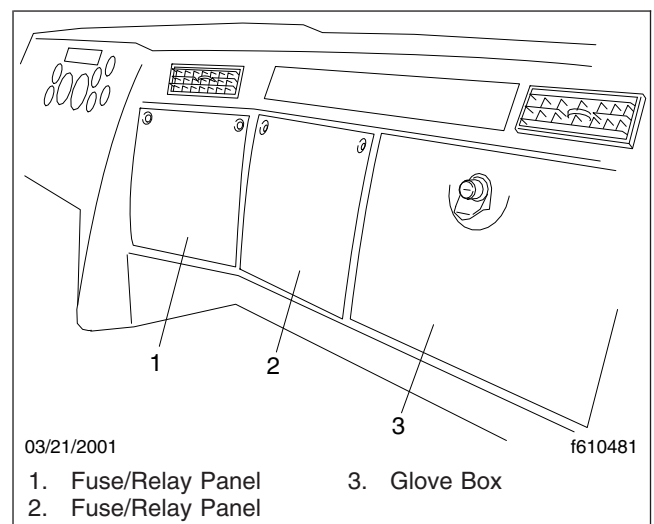

Fig. 7.6, Passenger-Side Dash Panels

Cab and Sleeper Features

Electronic Device Mount

Some vehicles may be equipped with an optional electronic device mounting station and 12 volt outlet on the dash. The standard bolt pattern allows the mounting of a variety of devices including navigation systems, cell phone holders, portable music players, and other electronic devices. Mounting systems can be found at www.ram-mount.com.

Lighting

See [Chapter 4](#) for detailed information regarding lighting controls.

Storage Areas

There is a storage bin located on the right-hand side of the overhead console ([Fig. 7.7](#)). This storage bin has an elastic mesh cover to keep objects in place. Some vehicles have an elastic-topped pouch, located on the rear cab panel between the seats. If the vehicle has a passenger bench seat, there are storage areas on the front of and inside the seat base.

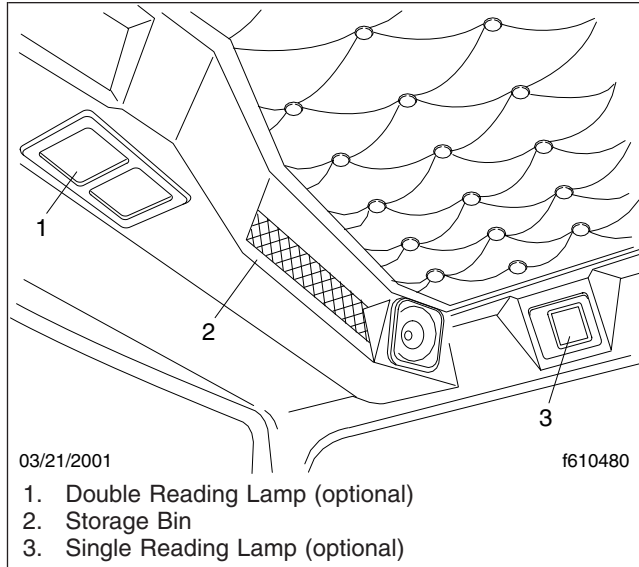

Fig. 7.7, Overhead Console Area

Sleeper Amenities

Western Star sleepers are available with many optional features. The following are some of those options.

NOTE: See [Chapter 5](#) for detailed information regarding sleeper climate controls and the digital clock.

Baggage Compartment Doors

To unlock, insert the baggage door key in the lock and turn counterclockwise 1/4-turn. Push the button, and the latch will spring open. To lock, press the latch in, turn the key clockwise 1/4-turn, then remove the key. If the baggage compartment door is unlocked, it can be opened simply by pushing the button.

Lighting

Reading lamps are operated manually with a rocker switch. The light beam direction is adjustable by moving the lens assembly in the desired direction. There are other courtesy lamps provided in the sleeper. These will operate when a cab door is opened. Some sleepers have light switches located on the cab or sleeper instrument panels.

Remote Engine Start

The remote engine start option ([Fig. 7.8](#)) includes a key switch, ignition light, CHECK engine warning light, and a STOP engine warning light. To activate the sleeper start controls, turn *on* the sleeper start switch on the dash, then turn the sleeper key switch to ON. Return the engine control to the cab by first turning the cab key switch ON and set the sleeper start switch to OFF.

Sleeper Door

The sleeper door is not intended for entry or exit. The door is intended only as a convenient means to stow or remove personal belongings in the sleeper area. To open the sleeper door, reach behind the latch cover at the rear upper corner, locate the flat handle, and push down.

IMPORTANT: The sleeper doors are two-stage latching. When closing the doors, ensure that they are completely latched to prevent wind noise and water intrusion.

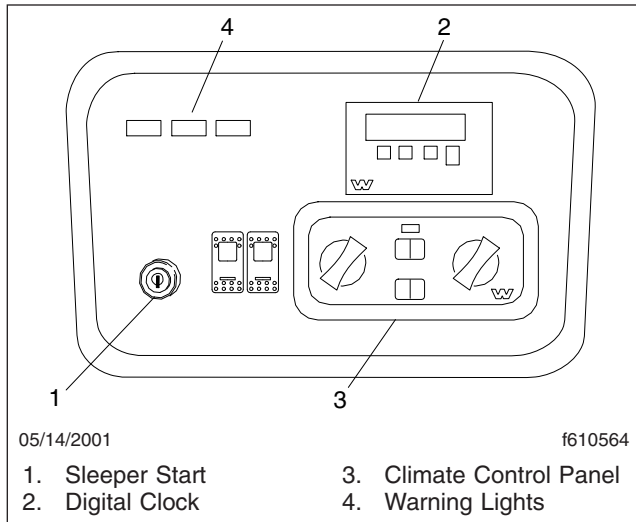

Fig. 7.8, Sleeper Control Panel

Sliding Side Window

The sliding side window is locked with an over-center toggle lever. When unlocked, the window may be adjusted to suit.

Vent

The air vent is operated using a simple, over-center latch. The vent will open in two directions. Push the knob firmly forward or back to open. The center position is closed.

8

Electrical System

Vehicle Power Distribution	8.1
Battery Disconnect Switches	8.2
Battery Access	8.3

Electrical System

Vehicle Power Distribution

Power Distribution, EPA10 and Newer

There are three standard power distribution modules (PDMs) on vehicles that are compliant with EPA10 and newer regulations: the dash electrical panel, the powertrain PDM, and the powernet distribution box (PNDB). See **Fig. 8.1** for the typical locations of the power distribution modules located in the engine compartment.

IMPORTANT: The covers on the underhood PDM units must be in place to protect against water splash and dust intrusion.

The powertrain PDM houses many of the fuses and relays for the engine, transmission, and aftertreatment system (ATS). There is a label on the cover of the powertrain PDM identifying the fuses and relays.

The PNDB houses up to three MIDI fuses and four ATO fuses. A label on the cover of the PNDB identifies the fuses.

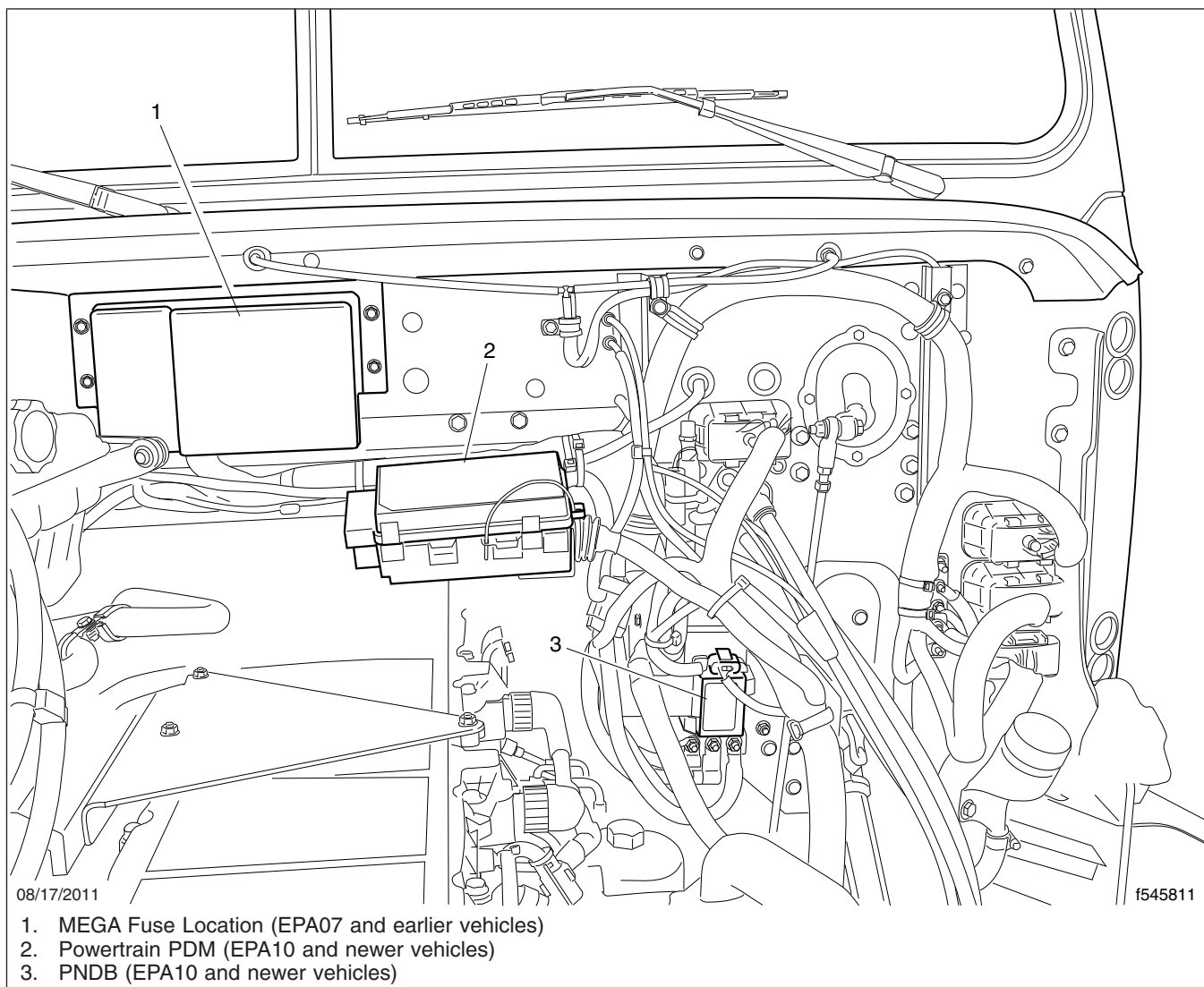

Fig. 8.1, PDM Locations

Vehicles may also be equipped with a secondary PNDB. The secondary PNDB sources power to any of the following:

- fleet management communications
- trailer end-of-frame connection
- shore power inverter
- bodybuilder PDM (housing any fuses and relays necessary for customer-installed truck body equipment)

The dash electrical panel is located inboard of the passenger-side glove box. Access to the panel is achieved by removing the four screws located in each corner of the panel cover. See **Fig. 8.2**. A decal showing the layout of the fuses, breakers, and relays is on the back of the panel cover. See **Fig. 8.3**.

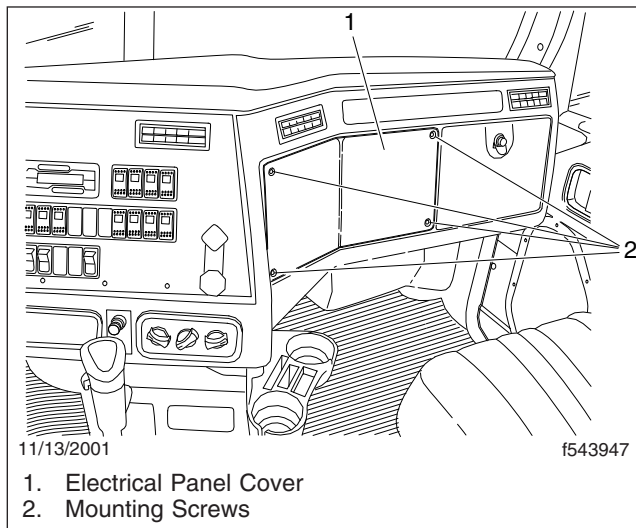

Fig. 8.2, Dash Panel

Pre-EPA10 Power Distribution

Vehicles that are not compliant with EPA10 or newer regulations have one PDM in the engine compartment (see **Fig. 8.1**) and two MEGA fuses in the dash electrical panel.

The dash electrical panel is located inboard of the passenger-side glove box. Access to the panel is achieved by removing the four screws located in each corner of the panel. See **Fig. 8.2**. A decal, showing the layout of the fuses, breakers and relays, is on the back of the panel cover. See **Fig. 8.3**.

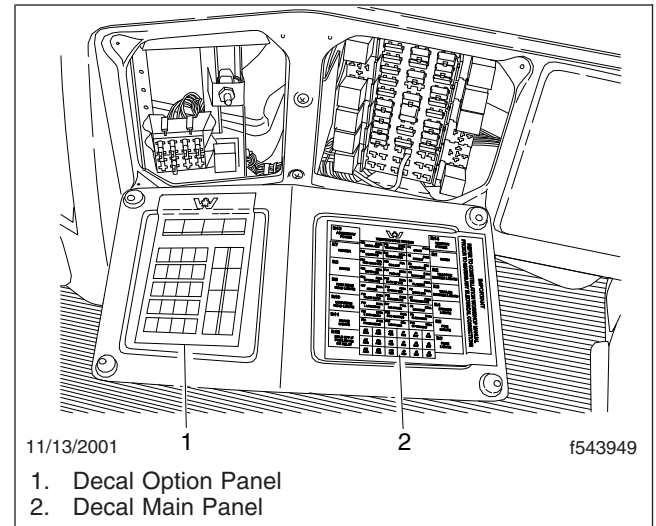

Fig. 8.3, Electrical Panel Decals

Battery Disconnect Switches

Your Western Star vehicle may be equipped with a cab load disconnect switch (CLDS) or a battery isolation switch.

Cab Load Disconnect Switch, EPA10 and Newer

The optional CLDS (**Fig. 8.4**) is used to minimize draw on the battery, and should be turned off when the vehicle is parked for an extended period of time.

When the CLDS is set to OFF, it signals the PNDB to disconnect battery power to the circuits powered by the MIDI fuses.

The CLDS is mounted on the cab floor outboard of the driver's seat, on the lower driver-side dash panel, or near the battery box.

IMPORTANT: The ignition should be turned OFF before using the CLDS.

Pre-EPA10 Battery Isolation Switch

The optional battery isolation switch (see **Fig. 8.5**) is located on the cab floor outboard of the driver's seat, on a bracket near the driver-side kick panel below the dash, or near the battery box. The battery isolation switch disconnects the power to most cab circuits and engine power wiring. Use it whenever the

Electrical System

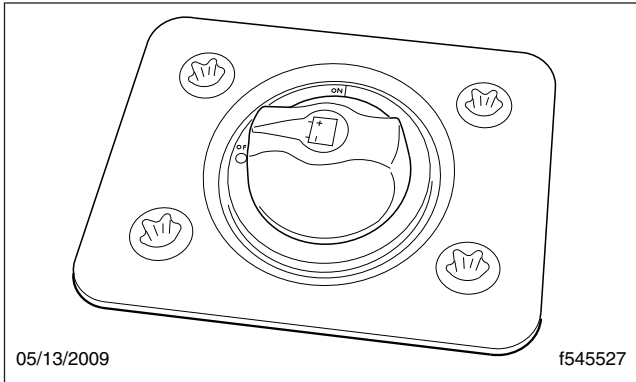

Fig. 8.4, Cab Load Disconnect Switch

vehicle is to be put out of service for extended periods.

IMPORTANT: The battery isolation switch does not completely isolate the batteries from the electrical system. For service operations that require that the batteries be disconnected, always shut down the engine and remove the negative battery cables.

NOTE: Whenever battery power is disconnected, clocks, radios, and the Datastar contrast must be reset.

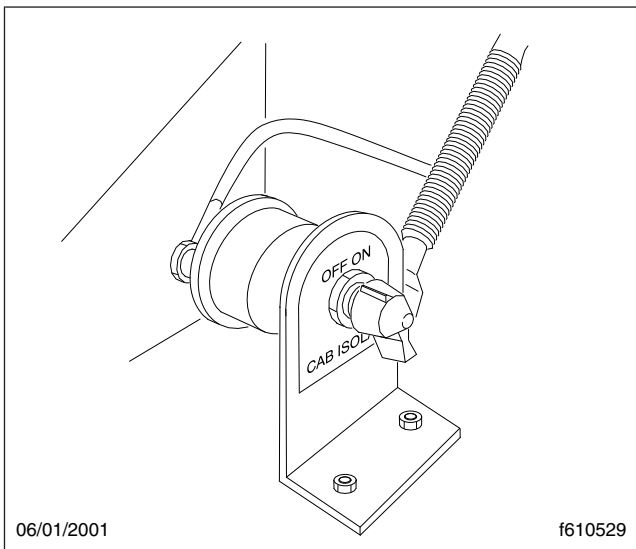

Fig. 8.5, Battery Isolation Switch

Battery Access

The batteries on a Western Star vehicle may be located in a variety of locations, including under the passenger seat, under the cab, behind the cab, or under the sleeper bunk, if equipped. Some vehicles may have two batteries in the step compartments on both sides of the vehicle.

9

Engine Starting, Operation, and Shutdown

Engine Starting	9.1
Engine Operation	9.1
Engine Shutdown	9.3
Engine Cooling	9.3

Engine Starting, Operation, and Shutdown

Engine Starting

This engine chapter is to serve as a guide for best practices only. Each engine model may have operating characteristics that are unique to that particular engine, and will be documented in the engine manufacturer's literature. Always refer to specific instructions and recommendations from the engine manufacturer.

NOTE: Before starting the engine, read **Chapter 3** for detailed information on how to read the instruments and see **Chapter 4** for detailed information on how to operate the controls. Read the engine manufacturer's operating instructions before starting the engine.



Never pour fuel or other flammable liquid into the air inlet opening in the air intake in an attempt to start the vehicle. This could result in a flash fire causing serious personal injury or property damage.

1. Before engine start-up, complete the engine pre-trip inspections in **Chapter 23**.
2. Set the parking brake.
3. Place the transmission in neutral. On vehicles with manual transmissions, fully depress the clutch pedal.
4. Turn the ignition switch to the ON position. The buzzer will sound for three seconds.
During cold conditions, the WAIT TO START lamp may illuminate. Wait until the lamp goes out before turning the ignition key to START.

NOTE: The length of time the WAIT TO START lamp remains illuminated depends on the ambient temperature. The lower the ambient temperature, the longer the lamp will be illuminated.

NOTE: The engine electronics supply the correct amount of fuel for starting the engine. Accelerator pedal pressure is unnecessary and could interfere with engine starting.

5. Turn the ignition key to the START position. Release the key the moment the engine starts.
6. Apply load gradually during the warm-up period.

NOTICE

If the oil pressure gauge indicates no oil pressure, shut down the engine within approximately ten seconds to avoid engine damage.

7. Check the oil pressure gauge for any drop in lubricating oil pressure or mechanical malfunction in the lubricating oil system.

Cold-Weather Starting

See the engine manufacturer's operation manual for starting aids that are approved for specific engines.

Starting After Extended Shutdown

Before engine start-up, complete the engine pretrip inspections in **Chapter 23**.

NOTICE

Failure to eliminate water-diluted lubricating oil may lead to serious engine damage at startup.

An engine in storage for an extended period of time (over winter, for example) may accumulate water in the oil pan through normal condensation of moisture on the internal surfaces of the engine. Oil diluted by water cannot provide adequate bearing protection at start-up. For this reason, change the engine oil and filters after extended storage.

Engine Operation

Safety and Environmental Considerations

All engines on Western Star vehicles comply with the requirements of the Federal (U.S.) Clean Air Act. Once an engine is placed in service, the responsibility for meeting both state and local regulations is with the owner/operator.

IMPORTANT: Depending upon local jurisdictional emissions guidelines, vehicles that are domiciled outside of the U.S. and Canada may not have engines and/or emissions aftertreatment systems that are compliant with EPA07, EPA10, or GHG14 regulations.

Engine Starting, Operation, and Shutdown

NOTICE

It is extremely important that the following guidelines be followed for engines that comply with EPA07 or newer regulations, or damage may occur to the aftertreatment device, and the warranty may be compromised.

- **Use ultralow-sulfur diesel with 15 ppm sulfur content or less.**
- **Do not use fuel blended with used engine lube oil or kerosene.**
- **Use only engine lube oil with a sulfated ash level less than 1.0 wt%; currently referred to as CJ-4 oil.**

Adequate maintenance of the engine and the diesel particulate filter (DPF) are the responsibility of the owner/operator, and are essential to keep the emission levels low. Good operating practices, regular maintenance, and correct adjustments are factors that will help keep emissions within the regulations.

The driver should be familiar with the vehicle warning system in order to bring the vehicle to a safe stop if the engine malfunctions. If the driver doesn't understand how the warning system works, an engine shutdown could occur, causing a safety hazard. See [Chapter 10](#) for more information.

Engine Break-In

Each engine must pass a full-load operating test on a dynamometer before shipment, thereby eliminating the need for a break-in. Before running the engine for the first time, follow the instructions in the engine manufacturer's operation manual specific to your engine.

Normal Operation



Do not operate the engine in an area where flammable vapors such as gasoline or diesel fumes are present. Shut off the engine when in an area where flammable liquids or gases are being handled. Failure to observe these precautions could result in serious injury or death.

Every engine has an operating range in which it performs most efficiently. The operating range extends

from maximum torque rpm at the low end, to engine rated speed at the high end. Most engines deliver best fuel economy when operated in the low- and mid-speed segments of the efficiency range and produce maximum horsepower at rated speed, which is also the recommended maximum speed of the engine. For further engine-specific information, refer to the engine manufacturer's operation manual.

Prolonged idling of engines is not recommended, and is illegal in some states. Idling produces sulfuric acid, that is absorbed by the lubricating oil, and eats into bearings, rings, valve stems, and engine surfaces. If you must idle the engine for cab heat or cooling, use the high idle function of the cruise control switches. An idle speed of 900 rpm should be enough to provide cab heat in ambient temperatures that are above freezing.

If the engine is programmed with the idle shutdown timer, ninety seconds before the preset shutdown time, the CHECK engine light will begin to flash at a rapid rate. If the position of the clutch pedal or service brake changes during this final ninety seconds the idle shutdown timer will be disabled until reset.

Cold-Weather Operation

Satisfactory performance of a diesel engine operating in low ambient temperatures requires modification of the engine, surrounding equipment, operating practices, and maintenance procedures. The lower the temperature, the greater the amount of modification required. For service products approved for use in cold weather for your engine, see the engine manufacturer's engine operation manual.

If satisfactory engine temperature is not maintained, maintenance costs will increase due to greater engine wear. If the engine coolant gets too cold, raw fuel will wash the lubricating oil off the cylinder walls and dilute the crankcase oil, causing all moving parts of the engine to suffer from poor lubrication.

If the engine is in good mechanical condition and the precautions necessary for cold-weather operation are taken, ordinary cold weather will not cause difficulty in starting or loss of efficiency.

The following points are important to observe when operating in cold weather:

- Check for cracks in the batteries, for corrosion of the terminals, and for tightness of the cable clamps at the terminals.

Engine Starting, Operation, and Shutdown

- Charge the batteries to full capacity. Replace damaged batteries.
- If equipped, turn off the load disconnect switch after the engine is shut down, to prevent battery discharge.
- Have the alternator output checked at an authorized service provider.
- Check the condition and tension of the drive belts.
- Refer to the engine manufacturer's operation manual for recommended heaters, low-viscosity lubricating oils, winter-grade fuels, and approved coolants.

NOTICE

For Detroit engines (EPA07 and newer), use of a winterfront is not recommended, as it can cause false fault codes with the engine and aftertreatment system, and possible emission component failures.

If using a winterfront, leave at least 25% of the grille opening exposed in sectioned stripes that run perpendicular to the charge-air-cooler tube-flow direction. This assures even cooling across each tube, and reduces header-to-tube stress, and possible chance of component failure. For engine-specific guidelines, see below:

Cummins and Mercedes-Benz engines: A winterfront may be used to improve cab heating while idling, and only when the ambient temperature remains below 10°F (-12°C).

Detroit engines (EPA07 and newer): Use of a winterfront is not recommended. Using a winterfront can cause excessive fan run time, increased fuel consumption, and failure of the DEF system heaters to operate correctly, resulting in fault codes, poor performance, and power reduction. A winterfront should only be used temporarily in the following situations:

- to improve cab heating while idling in an extremely cold ambient temperature;
- when the ambient temperature remains below -22°F (-30°C) and the engine is unable to maintain a running coolant temperature of 175°F (80°C) during normal over-the-road operation.

Engine Shutdown

1. With the vehicle stopped, set the parking brake and place the transmission in neutral.

NOTICE

Idle the engine one to two minutes before shutting it down. After hard operation, shutting down the engine without idling may cause damage to the turbocharger.

2. Allow the engine to idle one to two minutes before shutting it down.

NOTICE

Except in an emergency, do not shut down the engine when the coolant temperature is above 194°F (90°C). To do so could damage the engine.

3. Turn off the ignition switch and shut down the engine.

Engine Cooling

The cooling system used on all Western Star vehicles is a pressure type system. This raises the coolant boiling point, permitting higher operating temperatures. The coolant supplied in your vehicle will be a 50/50 mix of antifreeze and water, giving protection down to -35°F (-37°C). It is recommended that an antifreeze mixture be used at all times, as, in addition to providing frost protection, it is a more effective coolant, and has a higher boiling point than tap water.

Over-concentration of antifreeze or coolant conditioner can cause silicate to precipitate out of the coolant, forming silica gel on cooling system heat transfer surfaces (fuel coolers, oil coolers, radiators, and heater cores), resulting in reduced coolant flow and overheating.

Hard water (with high levels of calcium and magnesium ions) encourages formation of silica gel. Do not use softened water as the salt used to artificially soften it is corrosive. Most engine manufacturers prefer the use of distilled or de-ionized water to reduce the potential and severity of silicate dropouts.

Never exceed a 60/40 antifreeze-to-water ratio. If the level is low, add a 50/50 antifreeze solution to maintain solution concentrations. Note that checking the

Engine Starting, Operation, and Shutdown

engine coolant level is part of the pretrip inspection.
See [Chapter 23](#) for more information.

10

Optional Engine Systems

Engine Protection—Warning and Shutdown	10.1
Engine Idle Limiting	10.1
Cruise Control	10.2
Auxiliary Braking Applications	10.3
Power Takeoff (PTO) Governor	10.5

Optional Engine Systems

Engine Protection—Warning and Shutdown

The driver should be familiar with the vehicle warning system in order to bring the vehicle to a safe stop if the engine malfunctions. If the driver doesn't understand how the warning system works, an engine shutdown could occur.

The engine will begin a warning and shutdown process if the engine coolant temperature, coolant level, engine oil pressure, or exhaust aftertreatment system (ATS) reach preset levels. On some engines, the engine will also begin the warning and shutdown process when the engine oil temperature or the intake air temperature reach preset levels. Detroit Diesel engines will begin the warning and shutdown process if water is detected in the fuel.

See the engine manufacturer's operation manual for specific details for your vehicle.

See **Chapter 11** for the warning and shutdown modes associated with the ATS.

Electronic engine protection is programmable as an option, and can be specified as one of the following modes: DERATE and SHUTDOWN (factory default), WARNING, or OFF.

WARNING

When the red STOP engine or engine protection light illuminates, most engines are programmed to shut down automatically within 30 seconds. The driver must immediately move the vehicle to a safe location at the side of the road to prevent causing a hazardous situation that could cause bodily injury, property damage, or severe damage to the engine.

In DERATE and SHUTDOWN mode, the red STOP engine lamp will illuminate when the problem is serious enough to reduce power or speed. See **Fig. 10.1**. Engine power will ramp down, then the engine will shut down if the problem continues. The driver has 30 or 60 seconds (depending on the critical fault type) after the STOP engine lamp illuminates to move the vehicle safely off the road. If the vehicle cannot be moved to a safe location within that time, the engine can be restarted by turning the ignition switch OFF for at least five seconds, then back ON. Repeat this action until the vehicle is safely off the road.

Do not operate the vehicle further until the problem causing the shutdown has been corrected.

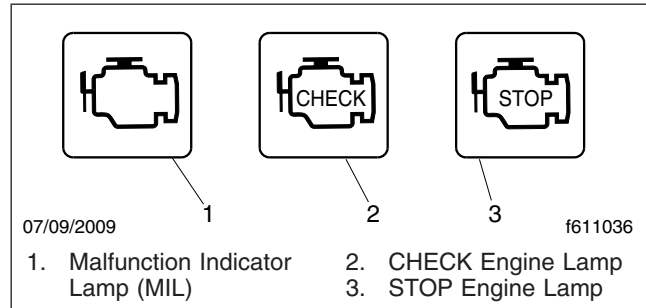

Fig. 10.1, Engine Warning Lights

Some vehicles may have a shutdown-override switch, which can be used to momentarily override the shutdown sequence. This switch resets the shutdown timer, restoring power to the level before the derate for another 30 or 60 seconds (depending on the critical fault type). The switch must be pressed again after five seconds to obtain a subsequent override.

In WARNING mode, the amber CHECK engine lamp will flash and a buzzer will sound. The engine electronics log the event for diagnostic purposes. The CHECK engine lamp will go out if the problem stops.

In OFF mode, the individual sensor indicator lamps will illuminate if a problem exists, but no shutdown action will be started and the event will not be recorded.

Engine Idle Limiting

Idle Shutdown Timer

This feature is an optional 1- to 100-minute idle shutdown system. Its purpose is to conserve fuel by eliminating excessive idling and allowing a turbo-charger cool-down period. Idle shutdown timing and parameters are programmable. See the engine manufacturer's operation manual for specific details for your vehicle.

California Engine Idle Limit

In order to meet the California Air Resources Board (CARB) engine idle limiting standard, vehicles are equipped with an engine idle shutdown feature. The automatic shutdown feature is required on all

California-certified engines (with the exception of engines used in specific vehicle types that are exempt from the requirement). Owners that wish to have the shutdown feature disabled on vehicles operating in California should consult with California authorities to determine if their vehicle qualifies for the exemption.

When the CARB engine idle limiting feature is enabled, the engine will typically shut down after five minutes of continuous idling when the transmission is in neutral and the parking brake is set. It will also shut down after 15 minutes when the transmission is in neutral, with the parking brake off. See the engine manufacturer's operation manual for specific details for your vehicle.

After an automatic shutdown, the engine may be restarted and operated normally.

Activating or momentarily changing the position of the brake pedal, clutch pedal, accelerator pedal, shutdown override switch, or parking brake during the final 30 seconds will cause the shutdown timer to reset.

Cruise Control

WARNING

Do not use the cruise control system when driving conditions do not permit maintaining a constant speed, such as in heavy traffic or on roads that are winding, icy, snow-covered, slippery, or roads with a loose driving surface. Failure to follow this precaution could cause a collision or loss of vehicle control, possibly resulting in personal injury or property damage.

NOTICE

When the cruise control is engaged, do not attempt to shift gears without using the clutch pedal. Failure to follow this precaution will result in a temporarily uncontrolled increase in engine speed. Transmission damage and gear stripping could result.

Cruise control is activated by two dash-mounted switches: an on/off switch (CRUISE CONTROL) and a Set/Decelerate/Resume/Accelerate switch. See [Fig. 10.2](#).

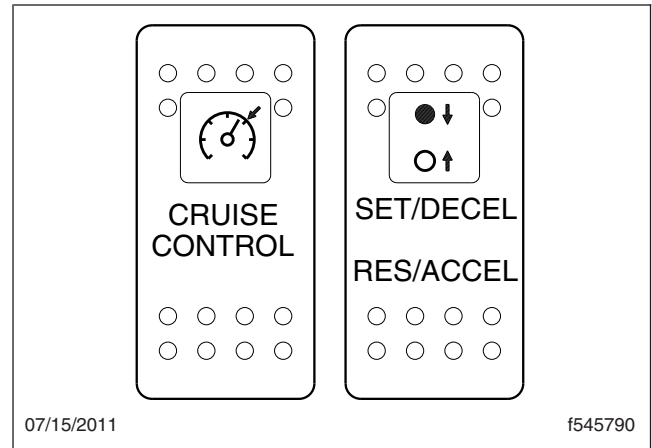

Fig. 10.2, Cruise Control Switches

Cruise at a particular speed

1. Press the upper part of the cruise control on/off switch to turn cruise control on.
2. Hold the accelerator pedal down until the speedometer reaches the desired speed.

NOTE: Cruise control is cancelled if the brake or clutch pedal is depressed, or engine speed drops below 1200 rpm.

3. Press the upper half of the Set/Resume/Accelerate/Decelerate switch momentarily to set the cruise speed (with the vehicle moving at the desired speed).

To decrease cruise speed, press and hold the upper half of the Set/Resume/Accelerate/Decelerate switch to decelerate slowly. Release the switch when the desired speed is achieved.

To increase cruise speed, press and hold the lower half of the Set/Resume/Accelerate/Decelerate switch to accelerate slowly. Release the switch when the desired speed is achieved.

Disengage cruise control

NOTE: The speed memory is lost whenever the ignition is turned off or the cruise control system is turned off.

1. Depress the brake pedal (automatic or manual transmissions)

or

Optional Engine Systems

Depress the clutch pedal (manual transmissions only).

NOTE: To resume the preselected cruise speed, increase vehicle speed to above minimum cruise control speed and momentarily press the lower half of the Set/Resume/Accelerate/Decelerate switch. Cruise will return to the last speed selected.

2. Press the lower half of the on/off switch.

Auxiliary Braking Applications

Engine Brake

Each engine manufacturer uses a specific engine brake for their engine. Regardless of the manufacturer, the engine brake is operated with the principles outlined in this chapter. Refer to the engine manufacturer's operation manual for details of their particular engine brake product.

WARNING

To avoid injury from loss of vehicle control, do not activate the engine brake system under the following conditions:

- on wet or slippery pavement, unless the vehicle is equipped with antilock braking system (ABS) and you have had prior experience driving under these conditions;
- when driving without a trailer or pulling an empty trailer;
- if the tractor drive wheels begin to lock, or there is fishtail motion after the engine brake is activated.

Whenever vehicle braking is required on good road conditions, the engine brake may be used in conjunction with the service brakes. There is no time limit for operation of the engine brake. However, an engine brake does not provide the precise control of, and is not a substitute for, service brakes.

WARNING

Usage of the engine brake as the primary braking system can cause unpredictable stopping distances, that could result in personal injury or

property damage. Service brakes are the primary vehicle braking system.

Two dash-mounted switches (Fig. 10.3) control the engine brake:

- The on/off switch (ENGINE BRAKE), is used to turn the engine brake on and off.
- The engine brake intensity switch (HIGH/MED/LOW or, in some cases, HIGH/LOW) controls the amount of engine braking. When the engine brake is on, a status bar illuminates on the intensity switch, indicating the current setting.

Since the engine brake is most effective at rated engine speed, gear selection is very important. Gearing down the vehicle within the limits of the rated engine speed makes the engine brake more effective. Recommended engine braking speed is above 1800 rpm and below the rated speed.

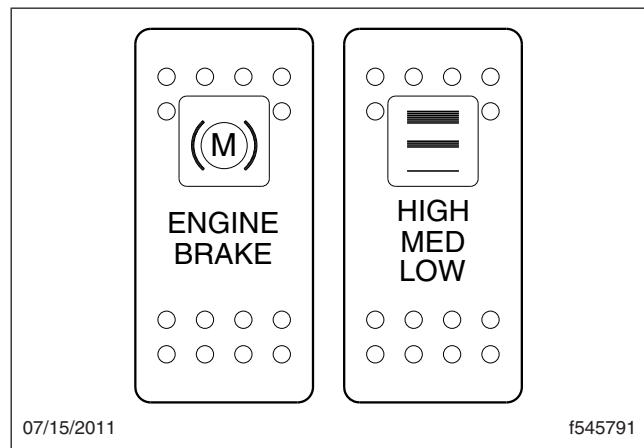

Fig. 10.3, Engine Brake Switches

WARNING

The engine brake must be disengaged when shifting gears using the clutch pedal. If the engine brake is engaged when the transmission is in neutral, the braking power of the engine brake can stall the engine, which could result in loss of vehicle control, possibly causing personal injury and property damage.

"Control speed" is the speed at which the engine brake performs 100 percent of the required downhill braking, resulting in a constant speed of descent.

The control speed varies, depending on vehicle weight and the downhill grade.

For faster descent, select a higher gear than that used for control speed. Service brakes must then be used intermittently to prevent engine overspeed and to maintain desired vehicle speed.

For slower descent, select a lower gear, being careful not to overspeed the engine. Occasional deactivation of the engine brake may be necessary to maintain the designated road speed under these conditions.

If the engine is equipped with both cruise control and an engine brake, the engine brake can operate automatically while cruise control is activated. The maximum amount of braking is selected with the dash switches. When the vehicle returns to the set cruise speed, the engine brake will turn off.

The engine brake will only operate when the accelerator and clutch pedals are fully released.

Vehicles equipped with ABS have the ability to turn the engine brake off if wheel slip is detected. The engine brake will automatically turn back on once wheel slip is no longer detected.

Engine Brake Operation

Depending on the brake type, the engine brake may be disabled when engine temperature falls below a set level.

NOTICE

Do not allow the engine to exceed its governed speed, or serious engine damage could result.

To operate the engine brake after the engine is warmed up and the vehicle is in motion:

1. Remove your feet from both the clutch and accelerator pedals.
2. Press the upper half of the on/off switch to turn the engine brake on. The engine brake will engage at the rate last set on the engine brake intensity switch.
3. Press the upper or lower half of the intensity switch to select the desired braking intensity.

Use the intensity switch set at the LOW position when driving on flat, open stretches of road. If the service brakes are still required to slow down on a grade, switch to a higher setting on the

dash switch to maintain constant speed of descent. Grade descent speed should be such that the service brakes are used infrequently and remain cool, thus retaining their effectiveness.

4. For maximum retarding, maintain the top governed speed of the engine through the appropriate selection of gears. When shifting gears, the engine brake will disengage when the clutch pedal is depressed, then engage when the clutch pedal is released.
5. To cancel the engine brake application, press the lower half of the on/off switch.

Exhaust Brake

An exhaust brake is an optional auxiliary braking system that assists but does not replace the service brake system on vehicles with Cummins engines. Exhaust brakes are not intended for use as the primary braking system during vehicle operation.

The exhaust brake is controlled by a dash-mounted rocker switch. See [Fig. 10.4](#).

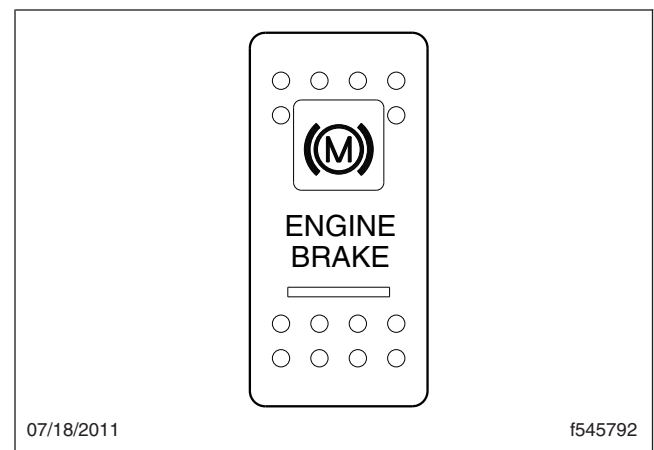

Fig. 10.4, Exhaust Brake Switch

To turn the exhaust brake on, press the upper half of the switch.

The exhaust brake turns itself off automatically. In addition, depressing the accelerator or clutch pedal deactivates the exhaust brake. The ABS, when active, also deactivates the exhaust brake.

Optional Engine Systems

Exhaust Brake Operation



Do not use the exhaust brake when driving on slippery or low-traction road surfaces. Failure to follow this precaution could result in a loss of vehicle control and possible personal injury or property damage.

1. Before starting the engine, make sure that the exhaust brake is off. Wait until the engine has reached normal operating temperature before activating the exhaust brake.
2. When approaching a downhill grade, press the upper half of the exhaust brake switch to turn the exhaust brake on. When the exhaust brake is on, the status bar is illuminated.
3. Remove your feet from the accelerator and clutch pedals.

NOTICE

Do not allow the engine to exceed its governed speed, or serious engine damage could result.

NOTE: The exhaust brake is only active when engine speed is between 1100 and 2700 rpm.

4. While going down a grade, use a low enough gear to safely descend with a minimum application of the service brakes. As a general guideline, use the same gear as you would to ascend the hill.

The following conditions should exist if the brake is operating properly:

- A slight change in the sound of the engine may be noticeable.
- Exhaust smoke should appear normal.
- Engine temperature should remain in the normal operating range.
- Road speed will usually decrease when the exhaust brake is applied during a descent. When the vehicle is carrying a heavy load or the grade is extremely steep, you may need to apply the service brakes occasionally.

- The exhaust brake retards the vehicle with a smooth braking effect.
- During a descent, the tachometer usually shows a drop in rpm, depending on the grade and the vehicle load.
- Depending on the grade and vehicle load, the retarding force of the exhaust brake may be noticeable.

5. Apply the service brakes to reduce engine rpm or make a slower descent by using a lower gear.
6. Make sure the exhaust brake is turned off before shutting down the engine.

Power Takeoff (PTO) Governor

Engine power takeoffs (PTO) are devices used to tap into engine power to run auxiliary devices, such as hydraulic pumps that power additional equipment. The following are general guidelines for operating a PTO.

- Set the parking brake and put the transmission in neutral.
- Press the upper half of the PTO switch. When the status bar light is steadily illuminated, the PTO is engaged and ready to operate. In stationary mode, the vehicle must remain in neutral with the parking brake set.
- To activate the mobile mode, shift from neutral to reverse, 1st, or 2nd gear. The clutch will open and the PTO will disengage for a moment.
- Touch the accelerator pedal to close the clutch and engage the PTO in mobile mode. The PTO may be operated with the transmission in neutral or reverse, 1st, or 2nd gears only. Do not attempt to change gears while the vehicle is moving. The transmission will ignore the request.
- To deactivate mobile mode, bring the vehicle to a stop. The clutch will open and shut down power to the PTO.
- To resume stationary mode, shift to neutral. The PTO will engage.
- To deactivate stationary mode, press the lower half of the PTO switch. When the light in the switch goes out, power to the PTO is shut off.

11

Emissions and Fuel Efficiency

Greenhouse Gas Emissions and Fuel Consumption Standards	11.1
EPA-Regulated Emissions Aftertreatment Systems	11.1
Diesel Exhaust Fluid and Tank, EPA10 and Newer Engines	11.3

Emissions and Fuel Efficiency

Greenhouse Gas Emissions and Fuel Consumption Standards

Vehicles and/or engines manufactured after December 31, 2006 and domiciled in the U.S. or Canada are required to meet all EPA and NHTSA regulations effective as of the vehicle build date. Engines manufactured between January 1, 2007 and December 31, 2009 meet EPA07 requirements. Engines manufactured between January 1, 2010 and December 31, 2012 meet EPA10 requirements.

Model year 2013 and later vehicles meet additional requirements as specified by NHTSA and EPA 2014 fuel efficiency and greenhouse gas emission standards (GHG14). These vehicles are equipped with components that increase fuel efficiency and reduce GHG emissions. Components may include, but are not limited to, low-rolling resistance tires; aerodynamic devices such as hood, cab/sleeper extenders, and fuel tank fairings; vehicle speed limiter; and idle shutdown timer. If replacement of any drag-reducing component is required, the replacement component must meet or exceed the drag reduction performance of the originally installed component in order to maintain compliance with GHG14.

EPA-Regulated Emissions Aftertreatment Systems

IMPORTANT: Depending on local jurisdictional guidelines, vehicles that are domiciled outside of the U.S. and Canada may not have emissions aftertreatment systems (ATS) that are compliant with EPA regulations.

NOTICE

Follow these guidelines for engines that comply with EPA07 or newer regulations, or damage may occur to the aftertreatment device (ATD) and the warranty may be compromised.

- Use ultralow-sulfur diesel with 15 ppm sulfur content or less.
- Do not use fuel blended with used engine lube oil or kerosene.

- Engine lube oil must have a sulfated ash level less than 1.0 wt %; currently referred to as CJ-4 oil.

IMPORTANT: Using non-specification fuels or oils can lead to shortened diesel particulate filter (DPF) cleaning or replacement intervals. For example, using CJ-4+ oil with 1.3% sulfated ash (30% more ash content) may result in the need for DPF cleaning or replacement 20 to 30% sooner than would normally be required.

IMPORTANT: See the engine manufacturer's operation manual for complete details and operation of the ATS.

EPA07 Engines

Engines built between January 1, 2007 and December 31, 2009 are required to meet EPA07 guidelines for reduced exhaust emissions of particulate matter and nitrogen oxides (NOx). NOx is limited to just over 1 gram per brake horsepower hour (g/bhp-hr), and particulate matter cannot exceed 0.01 g/bhp-hr.

The EPA07 ATS varies according to engine manufacturer and vehicle configuration, but the exhaust muffler is replaced by an aftertreatment device (ATD). Inside the ATD, the exhaust first passes over the diesel oxidation catalyst (DOC), then passes through the diesel particulate filter (DPF), which traps soot particles. The soot is burned to ash during a process called regeneration (regen).

EPA10 and Newer Engines

The EPA mandates that all engines built after December 31, 2009 must reduce the level of emissions exhausted by the engine to the following levels:

- Nitrogen Oxides (NOx) – 0.2 g/bhp-hr
- Particulate Matter (PM) – .01 g/bhp-hr

To meet EPA guidelines, engines that are compliant with EPA10 and newer regulations use an ATS that has, in addition to a DOC/DPF device like that used in an EPA07 ATD, a Selective Catalytic Reduction (SCR) device to reduce NOx downstream of the engine. After exhaust gases leave the DPF, a controlled quantity of diesel exhaust fluid (DEF) is injected into the exhaust stream. In the presence of heat, DEF is converted to ammonia gas, which reacts with NOx in the selective catalyst chamber to yield nitrogen and water vapor, which exit through the tailpipe.

Regeneration

The harder an engine works, the better it disposes of soot. If the exhaust temperature is high enough, a process called **passive regeneration** (regen) occurs as the vehicle is driven normally. However, if the engine isn't running hot enough, the electronic controls may initiate an **active regen**, whereby extra fuel is injected into the exhaust stream to superheat and reduce the soot trapped in the DPF to ash. Active regen happens only when the vehicle is moving above a certain speed, determined by the engine manufacturer. See your engine operation manual for complete details. Both active and passive regen happen automatically, without driver input.

WARNING

Active regeneration can occur automatically anytime the vehicle is moving. The exhaust gas temperature could reach 1500°F (800°C), which is hot enough to cause a fire, heat damage to objects or materials, or personal injury to persons near the exhaust outlet. The exhaust temperature can remain high even after the vehicle has stopped. When stopping the vehicle shortly after an automatic regen, ensure the exhaust outlets are directed away from structures, trees, vegetation, flammable materials, and anything else that may be damaged or injured by exposure to high heat.

See *Regen Switches*, below, for instructions on preventing automatic regen if necessary.

When operating conditions do not allow for ATD filter cleaning by active or passive regen, the vehicle may require a driver-activated **parked regen**. When this occurs, the DPF lamp illuminates, indicating that a regen is required. The driver must either bring the vehicle up to highway speed to increase the load (thus starting an active regen), or park the vehicle and initiate a parked regen. See *Regen Switches*, below, for instructions on initiating a parked regen.

Regen Switches

The regen request switch, located on the dash, is used to initiate a parked regen. See [Fig. 11.1](#). The function of the switch varies by the engine make and model in the vehicle. See the engine operation manual for switch operation details.

Some vehicles may be equipped with a regen request/inhibit switch. See [Fig. 11.2](#). To stop a regen

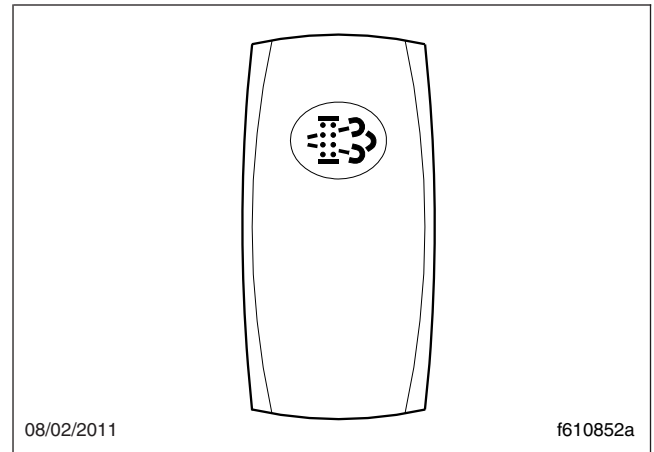

Fig. 11.1, Regen Switch

in progress or prevent the start of a regen, press the lower half of the switch. Regen is then delayed until the switch is no longer active.

NOTE: The regen switch can initiate a parked regen only when the DPF lamp is illuminated.

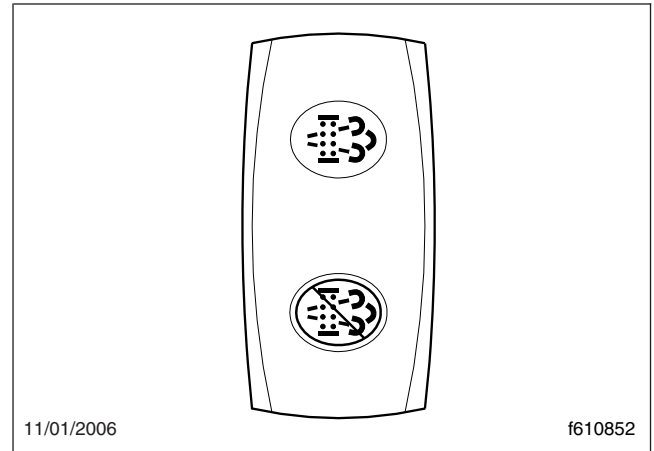

Fig. 11.2, Regen Request/Inhibit Switch

WARNING

During parked regen, exhaust temperatures are very high and could cause a fire, heat damage to objects or materials, or personal injury to persons near the exhaust outlet.

Before initiating a parked regen, make certain the exhaust outlets are directed away from structures, trees, vegetation, flammable materials, and

Emissions and Fuel Efficiency

anything else that may be damaged or injured by prolonged exposure to high heat.

To initiate a parked regen, perform the following steps.

1. Park the vehicle away from all flammable materials, put the transmission in neutral, and set the parking brake.
2. Start and warm the engine until the coolant temperature is at least 150°F (66°C).
3. Press and hold the regen switch for five seconds. The engine will increase rpm and initiate the regen process. As the regen process is initiated, engine rpm increases and the HEST lamp illuminates to indicate extremely high exhaust temperatures.

IMPORTANT: The driver must remain with the vehicle during the entire regen cycle.

4. The regen cycle will finish after 20 to 60 minutes, at which time engine idle speed drops to normal and the vehicle can be driven normally. The HEST lamp is extinguished when vehicle speed exceeds 5 mph (8 km/h) or the system has cooled to normal operating temperature.
5. To stop a parked regen at any time during the process:
 - depress the clutch pedal, brake pedal, or accelerator pedal;
 - press and hold the regen inhibit switch until idle returns to normal;
 - shut down the engine.

ATS Warning Lamps

There are three warning lamps that alert the driver of high exhaust temperature, the need to perform a parked regen or service the DPF, or of an engine fault that affects emissions. A decal attached to the driver's sun visor explains the ATS warning lamps. See [Fig. 11.3](#).

See [Fig. 11.4](#) for an explanation of the ATS warnings, and actions required to avoid engine protection sequences.

Malfunction Indicator Lamp (MIL)

A steadily illuminated yellow malfunction indicator lamp (MIL) indicates an engine fault that affects the emissions. See [Fig. 11.5](#).

DPF Lamp

When soot accumulates in the DPF and the DPF status lamp illuminates, see [Fig. 11.6](#), perform a parked regen or bring the vehicle up to highway speed to increase the load (thus starting an active regen).

If the DPF status lamp blinks while the CHECK engine lamp is illuminated, initiate a parked regen immediately in order to prevent an engine derate.

If the red STOP engine lamp illuminates with the blinking DPF lamp and the CHECK engine lamp, begin a parked regen in order to prevent an engine shutdown. Park the vehicle and perform a parked regen.

High Exhaust System Temperature (HEST) Lamp

Slow (10-second) flashing of the high exhaust system temperature (HEST) lamp indicates that a parked regen is in progress, and the engine's high idle speed is being controlled by the engine software, not the vehicle driver.

Steady illumination of the HEST lamp alerts the driver of high exhaust temperature during the regen process if the vehicle speed is below 5 mph (8 km/h), or during a parked regen. See [Fig. 11.7](#).

Maintenance

Authorized service facilities must perform any DPF service. For warranty purposes, maintain a record that includes:

- date of cleaning or replacement;
- vehicle mileage;
- particulate filter part number and serial number.

Diesel Exhaust Fluid and Tank, EPA10 and Newer Engines

Diesel Exhaust Fluid

Diesel exhaust fluid (DEF) is used in the ATS to lower NO_x in the exhaust stream. DEF is colorless

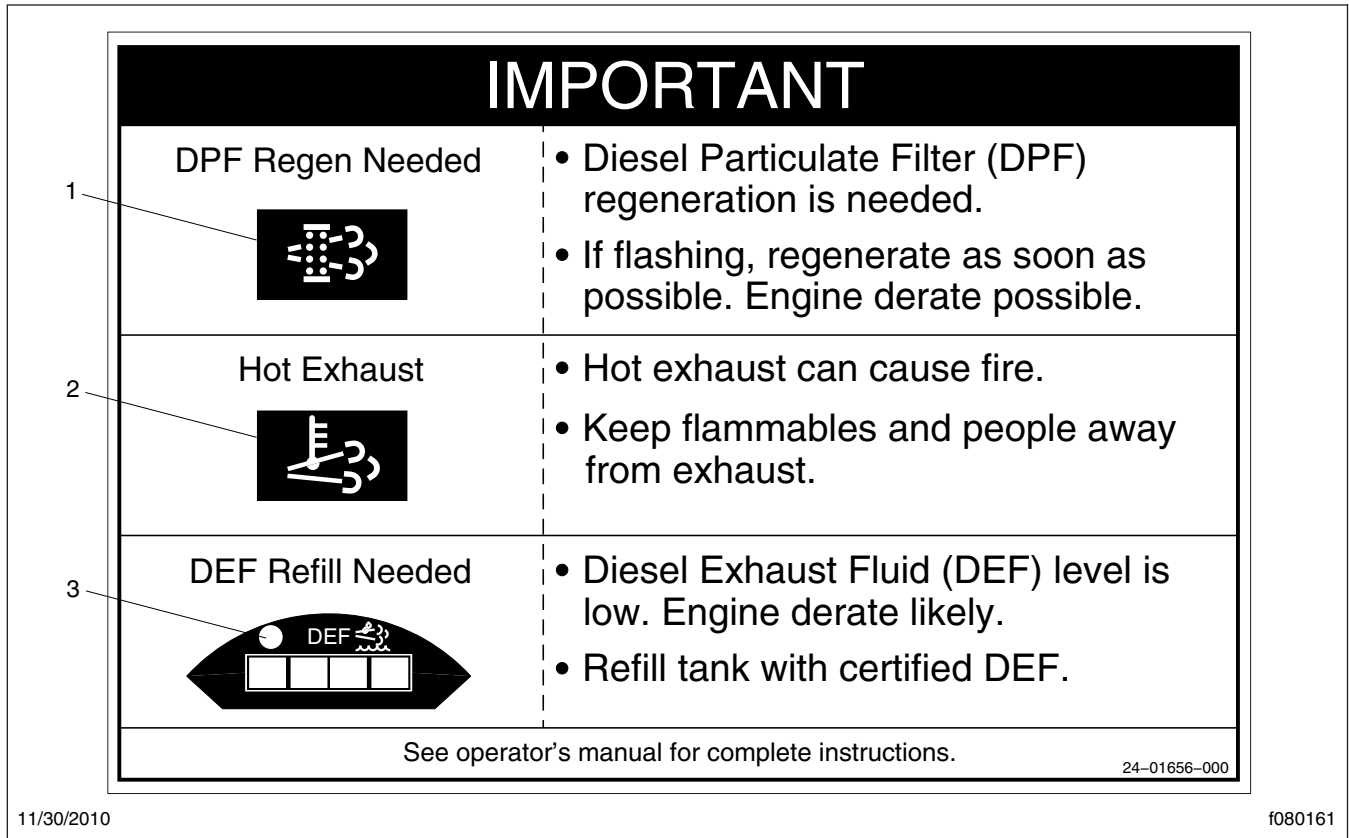

Fig. 11.3, Warning Lamp Decal, Sun Visor

and close to odorless (it may have a slightly pungent odor similar to ammonia). It is nontoxic, nonflammable, and biodegradable. It is mildly corrosive to aluminum, but does not affect the strength or structure of the aluminum.

White crystals may be noticeable around components that come into contact with DEF. The crystals are easily removed with water.

DEF consumption varies depending on ambient conditions and vehicle application.

Freezing Conditions

DEF freezes to slush at around 12°F (-11°C). It is not damaged or destroyed if frozen, and is fully usable when thawed. The DEF in the tank is allowed to freeze while a vehicle is non-operational. At start-up, normal operation of the vehicle is not inhibited if the DEF is frozen; an immersion heater with engine coolant flowing through it warms the DEF once the engine is running, allowing the SCR system to operate.





Pre-2013 DEF supply lines are electrically-heated and are purged when the engine is shut down; complete purging of the DEF lines requires approximately five minutes after the engine is shut down.

DEF supply lines with engine model year 2013 and newer are designed to survive freezing conditions while containing DEF, so purging is not required.

DEF Tank

Engines that are compliant with EPA10 and newer regulations are equipped with a DEF tank located on the driver's side of the vehicle behind the battery box or forward of the fuel tank. See Fig. 11.8. The DEF tank has a 19 mm filler neck inlet that prevents the hose from a diesel outlet from being inserted, and has a blue cap for easy identification.

Emissions and Fuel Efficiency

EXHAUST AFTERTREATMENT SYSTEM INFORMATION					
INDICATOR LAMP(S)	 (Solid) Level 1	 (Flashing) Level 2	 (Flashing) CHECK Level 3	 (Flashing) CHECK STOP Level 4	 WARNING
Indicator Lamp Message(s)	Filter Regeneration Recommended	Filter Regeneration Necessary	Parked Regeneration Required – Engine Derate	Parked Regeneration Required – Engine Shut Down	HEST (High Exhaust System Temperature)
Diesel Particulate Filter Condition	Filter is reaching capacity.	Filter is now reaching maximum capacity.	Filter has reached maximum capacity.	Filter has exceeded maximum capacity.	Flashing A regeneration is in progress.
Required Action	Bring vehicle to highway speeds to allow for an Automatic Regeneration or perform a Parked Regeneration.	To avoid engine derate bring vehicle to highway speeds to allow for an Automatic Regeneration or perform a Parked Regeneration as soon as possible.	Vehicle must be parked and a Parked Regeneration must be performed – engine will begin derate.	Vehicle must be parked and a Parked Regeneration or Service Regeneration must be performed. Check engine operator's manual for details – engine will shut down.	Solid Exhaust Components and exhaust gas are at high temperature. When stationary, keep away from people and flammable materials or vapors.
For a driver performed Parked Regeneration, vehicle must be equipped with a dash mounted Regeneration Switch.					
See Engine Operator's Manual for complete Regeneration Instructions.					
<small>24-01583-0008</small>					

06/29/2009

f080147

Fig. 11.4, ATS Warning Lamps

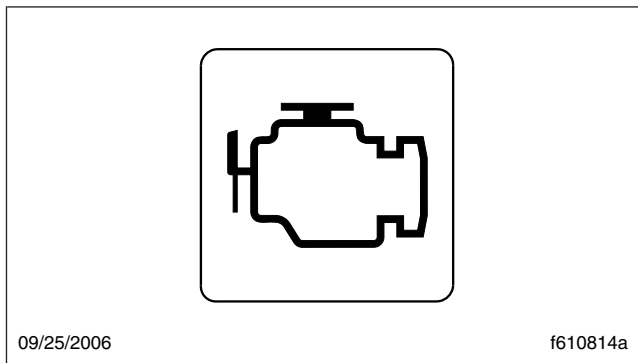

Fig. 11.5, Malfunction Indicator Lamp (MIL)

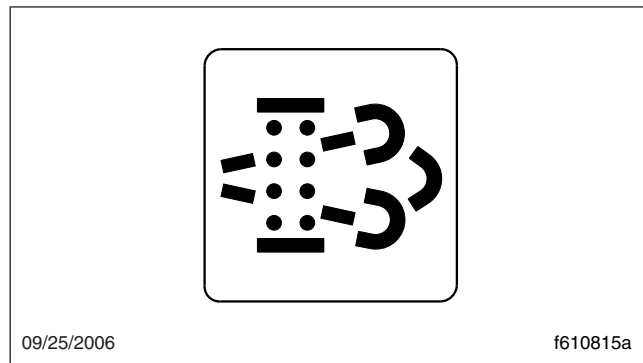

Fig. 11.6, Diesel Particulate Filter (DPF) Status Lamp

Fuel/DEF Gauge

The diesel fuel and DEF levels are measured in a dual-purpose gauge. See Fig. 11.9.

Fuel level is indicated at the top of the gauge. Below the fuel level, a low fuel warning lamp illuminates amber when the fuel level drops below 1/8th of the capacity.

The lower portion of the gauge has a DEF warning lamp that illuminates amber when the DEF tank is near empty, and a lightbar that indicates the level of

DEF in the tank. The DEF light bar illuminates as follows.

- Four bars illuminated green—Between 75% and 100% full
- Three bars illuminated green—Between 50% and 75% full
- Two bars illuminated green—Between 25% and 50% full
- One bar illuminated green—Between approximately 10% and 25% full

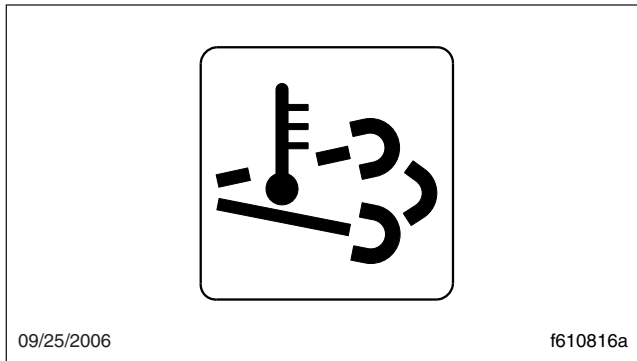

Fig. 11.7, High Exhaust System Temperature (HEST) Lamp

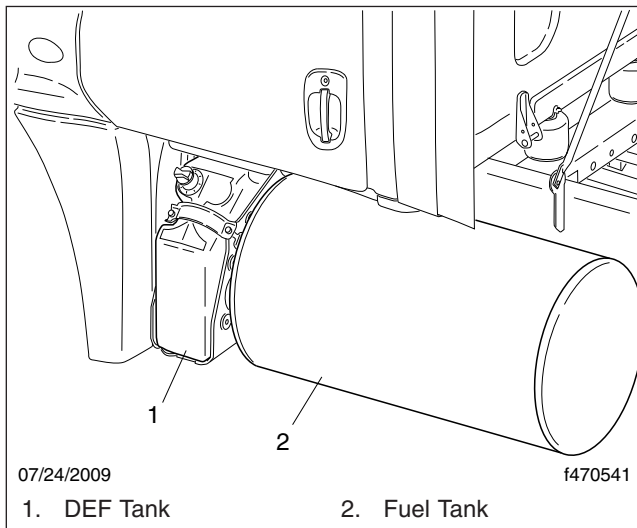

Fig. 11.8, DEF Tank Located Forward of the Fuel Tank

- One bar illuminated amber—DEF very low, refill DEF
- One bar flashing red—DEF empty, refill DEF

DEF Warnings and Engine Limits

IMPORTANT: Ignoring the DEF warning lights results in limited engine power, with the application of a 5 mph (8 km/h) speed limit.

DEF Level Low—Initial Warning

When the DEF level is low, the following lamps notify the driver. See [Fig. 11.10](#). Refill the DEF tank in order to cancel the warning sequence.

- One bar of the DEF level indicator illuminates amber—DEF very low, refill DEF.
- The DEF warning lamp illuminates solid amber.

DEF Empty

When the DEF level reads empty, the following lamps notify the drive. See [Fig. 11.11](#).

- One bar of the DEF level indicator flashes red—DEF empty, refill DEF.
- The DEF warning lamp flashes amber.
- The MIL lamp illuminates.

Pre-2013 Detroit engines: Power is limited, with a 55 mph (90 km/h) speed limit.

Cummins and 2013 Detroit engines: Power is limited with progressively harsher engine power limits applied.

DEF Tank Empty and Ignored

If the empty warning is ignored and the DEF tank is not refilled, the red STOP engine lamp illuminates in addition to the MIL lamp and CHECK engine lamp (on vehicles with a Cummins ISB or ISC/L engine.) See [Fig. 11.12](#).

If the DEF is not refilled, a 5 mph (8 km/h) speed limit is applied after the next engine shutdown, while parked and idling, or if a fuel refill is detected.

DEF Contamination or SCR Tampering

NOTICE

Once contaminated DEF or tampering has been detected, the vehicle must be taken to an authorized service facility to check the SCR system for damage and to deactivate the warning lights and engine limits.

If contaminated DEF or tampering with the ATS is detected, the DEF warning light flashes and the MIL lamp illuminates to warn the driver. The CHECK engine lamp also illuminates on vehicles with a Cummins ISB or ISC/L engine. See [Fig. 11.12](#).

- Detroit engines: Engine power is limited with progressively harsher limits applied. If the fault

Emissions and Fuel Efficiency

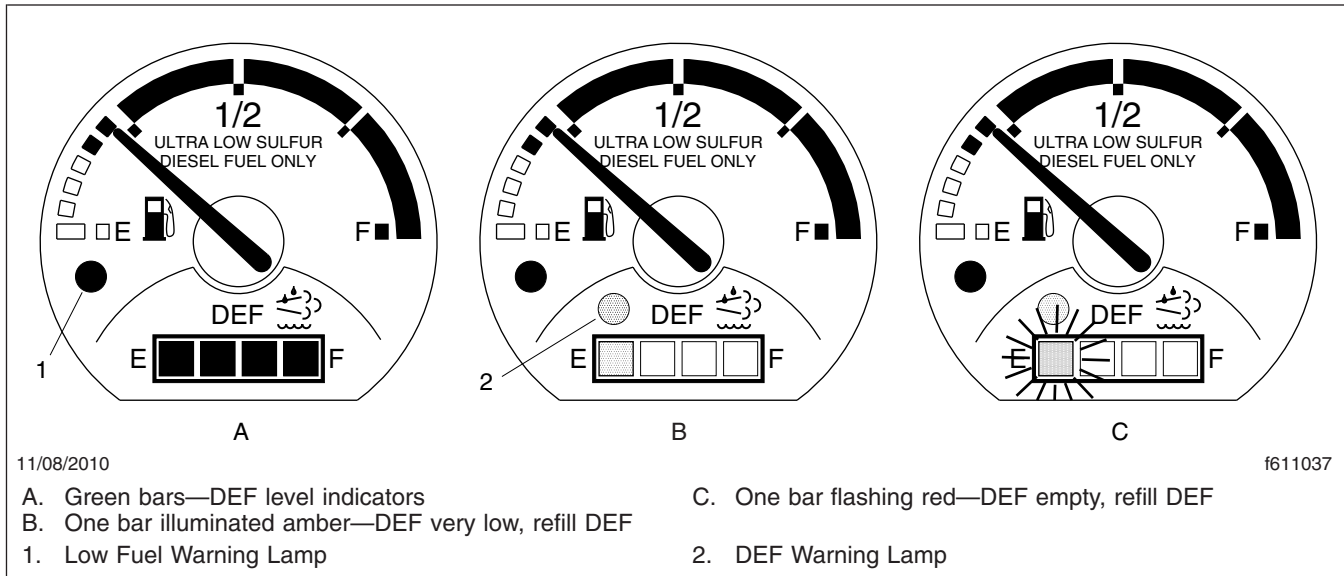

Fig. 11.9, Fuel/DEF Gauge

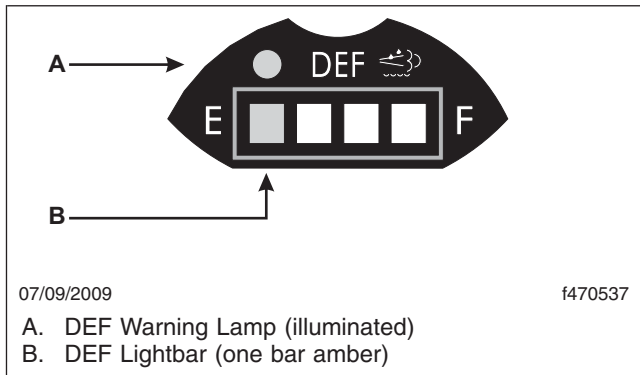

Fig. 11.10, DEF Level Low Initial Warning

is not corrected, the STOP engine light illuminates and a 5 mph (8 km/h) speed limit is applied after the next engine shutdown, while parked and idling, or if a fuel refill is detected.

- Cummins engines: Engine power is limited with progressively harsher limits applied. If the fault is not corrected, the STOP engine light illuminates and a 5 mph (8 km/h) speed limit is applied after the next engine shutdown, or while parked and idling.

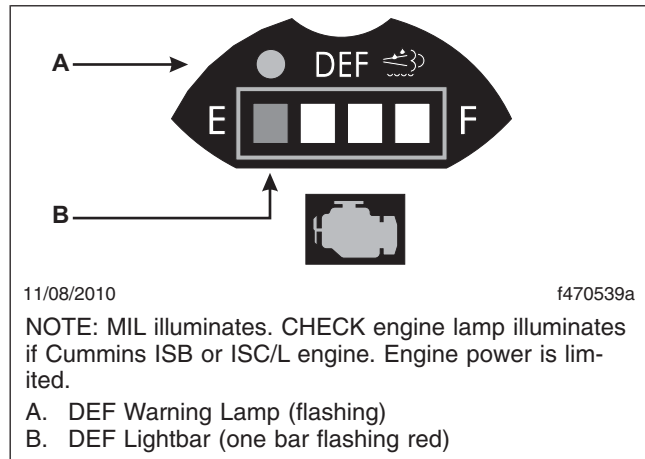

Fig. 11.11, DEF Empty Warning

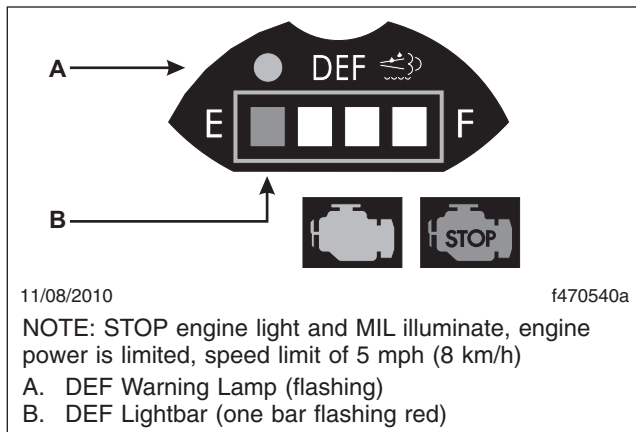

Fig. 11.12, DEF Empty and Ignored Warning

12

Brake Systems

Air Brake System	12.1
Meritor WABCO® Antilock Braking System	12.3
Roll-Stability Control	12.5

Brake Systems

Air Brake System

General Information, Brake System

A dual air brake system consists of two independent air systems that use a single set of brake controls. Each system has its own reservoirs, plumbing, and brake chambers. The primary system operates the service brakes on the rear axle; the secondary system operates the service brakes on the front axle. Service brake signals from both systems are sent to the trailer.

Brake System Operation



Do not operate the vehicle with the front brakes backed off or disconnected. Backing off or disconnecting the front brakes will not improve vehicle handling and may lead to loss of vehicle control, resulting in property damage or personal injury.

Before driving your vehicle, allow time for the air compressor to build up a minimum of 100 psi (690 kPa) pressure in both the primary and secondary systems. Monitor the air pressure system by observing the dual system air pressure gauge and the low-air-pressure warning light and buzzer. The warning light and buzzer shut off when air pressure in both systems reaches 64 to 76 psi (441 to 524 kPa).

IMPORTANT: Before driving the vehicle, secure all loose items in the cab so that they will not fly forward during a full brake application. Make sure all passengers are wearing seat belts.

During normal brake stops, depress the foot brake control pedal until braking action slows down the vehicle. Increase or decrease the pressure on the pedal so that the vehicle comes to a smooth, safe stop. Apply the spring parking brakes if the vehicle is to be parked.

When parking a vehicle attached to a trailer that does not have spring parking brakes, apply the tractor parking brakes. Chock the trailer tires before disconnecting the vehicle from the trailer.

IMPORTANT: An air brake proportioning system may be used in tractor air brake systems when the vehicle is not equipped with antilock braking system (ABS). When operating in bobtail mode,

the rear brake chambers (on which the axle load has been greatly reduced) receive reduced (proportional) air pressure, while the front axle brake chambers receive full (normal) air pressure. This results in a different brake pedal "feel," as the pedal seems to require more travel and/or effort to slow or stop the vehicle. However, the air brake proportioning system actually improves vehicle control when the tractor is in bobtail mode. When the tractor is towing a trailer, the rear brake chambers will receive full (normal) application air pressure.

NOTE: If equipped with main and auxiliary transmissions, do not shift both transmissions into neutral while the vehicle is rolling. Shifting both transmissions back into gear would be difficult while the vehicle is rolling.

On tractor-trailer vehicles, if both the primary and secondary systems become inoperative, the trailer service brakes or spring parking brakes will automatically apply when air pressure drops below 35 to 45 psi (241 to 310 kPa). The tractor spring parking brakes will automatically apply when air pressure drops below 20 to 30 psi (138 to 207 kPa). On straight trucks, spring parking brakes will apply when air pressure drops below 20 to 30 psi (138 to 207 kPa). Do not wait for the brakes to apply automatically. When the warning light and buzzer first come on, immediately bring the vehicle to a safe stop. Before continuing operation of the vehicle, correct the cause of the air loss.



If a trailer or combination vehicle is not equipped with spring parking brakes, do not park it by pulling out only the trailer air supply valve knob. This would apply only the trailer service brakes. If air were to bleed from the trailer brake system, the trailer brakes would release, possibly causing an unattended runaway vehicle.



Do not use the trailer service brakes for parking; they are not designed for this purpose. If air bleeds out of the trailer air tank during parking, the vehicle could roll, causing serious personal injury or property damage.

NOTICE

Never apply the service and spring parking brakes simultaneously. To do so transmits excessive input force to the brake components, which could damage or cause eventual failure of brake actuating components.

Do not use the spring parking brakes if the service brakes are hot, such as after descending a steep grade. To do so could damage the brakes. Allow hot brakes to cool before using the spring parking brakes.

Do not use the spring parking brakes during freezing temperatures if the service brakes are wet. To do so could cause them to freeze. If the brakes are wet, drive the vehicle in low gear and lightly apply the brakes to heat and dry them.

Brake Controls

The trailer brake lever is used for applying the trailer brakes without applying the truck or tractor service brakes. It is usually mounted on the steering column. See Fig. 12.1. The valve can be partially or fully applied, but in any partially on position it will be overridden by a full application of the service brake pedal. Moving the lever clockwise (down) applies the trailer brakes, while moving it counterclockwise (up) releases the trailer brakes. The lever will remain in the selected position until it is manually moved.

The red octagonal-shaped knob actuates the trailer air supply valve. See Fig. 12.2. After the vehicle's air hoses are connected to a trailer and the pressure in both air systems is at least 65 psi (448 kPa), the trailer air supply valve must be pushed in. It should stay in to charge the trailer air supply system and to release the trailer spring parking brakes.

Pull the trailer air supply valve out before disconnecting a trailer or when operating a vehicle without a trailer. If pressure in both air systems drops to 35 to 45 psi (241 to 310 kPa), the trailer air supply valve automatically pops out, exhausting the trailer air supply, and applying the trailer service or spring parking brakes.

The yellow diamond-shaped knob actuates the parking brake valve. See Fig. 12.2. Pulling out the parking brake valve applies both the tractor and trailer spring parking brakes and automatically causes the trailer air supply valve to pop out.

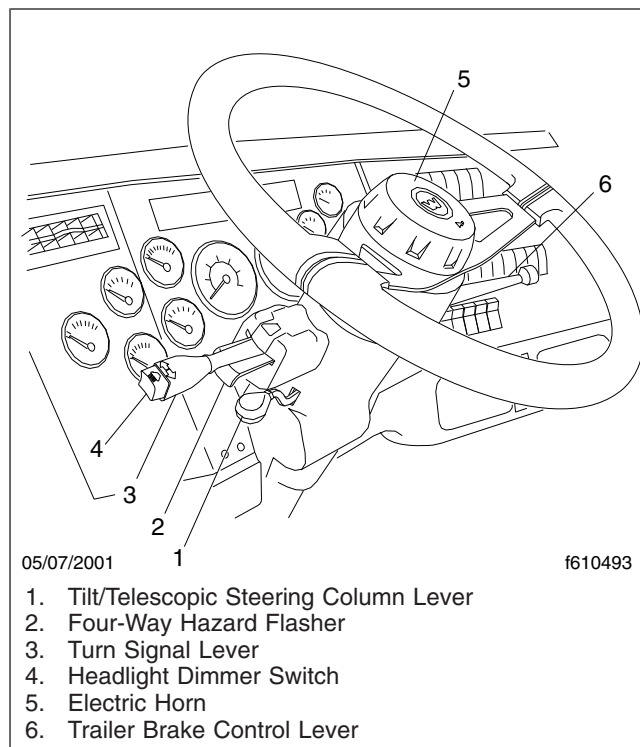

05/07/2001

f610493

1. Tilt/Telescopic Steering Column Lever
2. Four-Way Hazard Flasher
3. Turn Signal Lever
4. Headlight Dimmer Switch
5. Electric Horn
6. Trailer Brake Control Lever

Fig. 12.1, Trailer Brake Control Lever

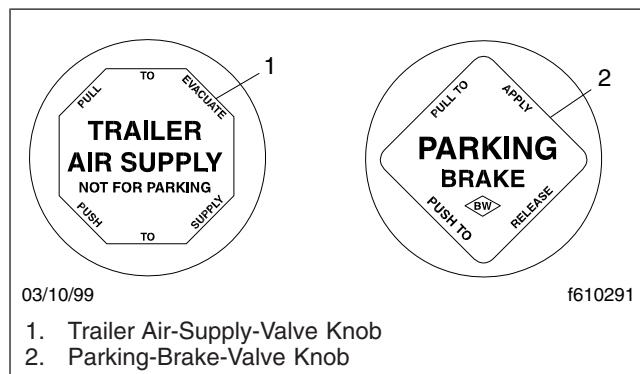

03/10/99

f610291

1. Trailer Air-Supply-Valve Knob
2. Parking-Brake-Valve Knob

Fig. 12.2, Brake Valve Knobs

If the trailer is not equipped with spring parking brakes, pulling out the parking brake valve applies the tractor spring parking brakes and the trailer service brakes. When the tractor and trailer parking brakes (or trailer service brakes) are both applied, the trailer brakes are released by pushing in the trailer air supply valve, leaving the tractor parking brakes applied. Air pressure in the primary or secondary reservoir must be at least 65 psi (448 kPa)

Brake Systems

before the tractor spring parking brakes, or the trailer service or spring parking brakes, can be released.

On trailers not equipped with spring parking brakes, chock the trailer tires before disconnecting the truck or tractor.

When parking a truck or tractor with a trailer (combination vehicle), and the trailer is not equipped with spring parking brakes, apply the truck or tractor spring parking brakes.

Brake System Conditions

The warning light and buzzer come on if air pressure drops below 64 to 76 psi (441 to 524 kPa) in either system. If this happens, check the dual system air pressure gauge to determine which system has low air pressure. Although the vehicle's speed can be reduced using the foot brake control pedal, either the front or rear service brakes will not be operating at full capacity, causing a longer stopping distance. Bring the vehicle to a safe stop and have the air system repaired before continuing.

IMPORTANT: In the event of a total loss of service brakes with full system air pressure, use the parking brake control valve (yellow knob) to bring the vehicle to a complete stop in the safest location possible.

Before a vehicle with insufficient system air pressure can be moved, the spring parking brakes must be released by applying an external air source at the gladhands, or by manually caging the parking brake springs.

WARNING

Do not release the spring parking brakes and then drive the vehicle. There would be no means of stopping the vehicle, which could result in serious personal injury or vehicle damage. Before releasing the spring parking brakes, make the connection to a towing vehicle or chock the tires.

After correcting the brake system problem, uncage the spring parking brakes before resuming normal vehicle operation.

Primary Air Brake System

Loss of air pressure in the primary air system causes the rear service brakes to become inoperative. The

secondary air system will continue to operate the front brakes and the trailer brakes (if equipped).

Secondary Air System

Loss of air pressure in the secondary air system causes the front axle brakes to become inoperative. The primary air system will continue to operate the rear service brakes and the trailer brakes (if equipped).

Automatic Slack Adjusters

Automatic slack adjusters should never be manually adjusted except during routine maintenance of the foundation brakes (e.g., replacing shoes), during slack adjuster installation, or in an emergency situation.

When the brake pushrod stroke exceeds the legal brake adjustment limit on a vehicle, there is likely a mechanical problem with the foundation brake components or the adjuster is improperly installed.

Visit a repair facility as soon as possible when brakes equipped with automatic slack adjusters are determined to be out of adjustment.

NOTICE

Manually adjusting an automatic slack adjuster to bring the pushrod stroke within legal limits is not repairing. In fact, continual adjustment of automatic slack adjusters may result in premature wear of the adjuster itself. Further, the improper adjustment of some automatic slack adjusters may cause internal damage to the adjuster, thereby preventing it from properly functioning.

Meritor WABCO® Antilock Braking System

The Meritor WABCO Antilock Braking System (ABS) is an electronic wheel speed monitoring and control system that works with the standard air brake system. ABS passively monitors vehicle wheel speed at all times, and controls wheel speed during emergency stops or wheel lock situations.

IMPORTANT: For proper ABS system operation, do not change tire sizes. The sizes of the tires installed during production are programmed into the electronic control unit. Installing different

sized tires could result in a reduced braking force, leading to longer stopping distances.

ABS includes signal-generating tone wheels and sensors located in the wheel hubs of each sensed wheel. The sensors transmit vehicle wheel speed information to an electronic control unit (located behind the center dash). The control unit's main circuit interprets the speed sensor signals and calculates wheel speed, wheel retardation, and a vehicle reference speed. If the calculations indicate wheel lockup, the main circuit signals the appropriate modulator valve to reduce braking pressure. During emergency braking, the modulator valve alternately reduces, increases, or maintains air pressure supply in the brake chamber to prevent front and rear wheel lockup.

The Meritor WABCO ABS combines one front-axle control channel with one rear-axle control channel to form one control circuit. For example, the sensor and modulator valve on the left-front axle form a control circuit with the sensor and modulator valve on the right-rear axle. If, during vehicle operation, the safety circuit senses a failure in any part of the ABS, the tractor ABS warning lamp illuminates and the control circuit where the failure occurred is switched to normal braking action. The remaining control circuit will retain the ABS effect. Even if the ABS is completely inoperative, normal braking ability is maintained. An exception would be if a modulator valve (or combination modulator valve) is damaged and inoperative. As these components are an integral part of the air brake system, normal braking may be impaired or inoperative.

Although the ABS improves vehicle control during emergency braking situations, the driver still has the responsibility to change driving styles depending on existing traffic and road conditions. For example, the ABS cannot prevent an accident if the driver is speeding or following too closely.

During emergency or reduced-traction stops, fully depress the brake pedal until the vehicle comes to a safe stop. *Do not pump the brake pedal.* With the brake pedal fully depressed, the ABS will control all wheels to provide steering control and a reduced braking distance.

ABS, Trailer Compatibility

The Meritor WABCO ABS is designed to communicate with a trailer ABS, if they are compatible. Com-

patibility will result in the illumination of the trailer ABS lamp during vehicle start-up and fault detection. See [Fig. 12.3](#).

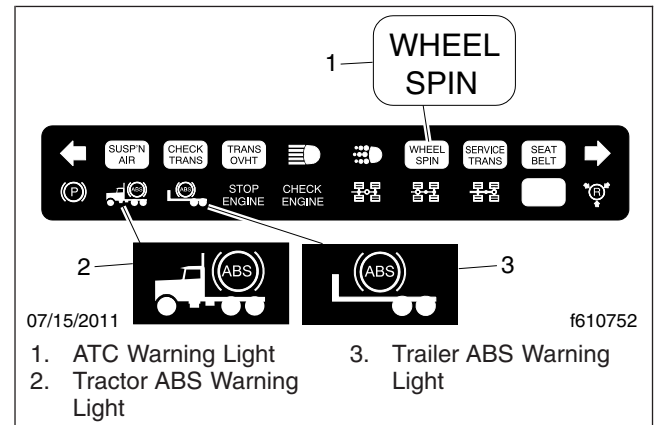

Fig. 12.3, ABS Dash Lights

The trailer ABS lamp will not illuminate unless a compatible trailer is connected to the tractor. The dash-mounted lamp will operate as follows when a compatible trailer is properly connected to the tractor:

- When the ignition key is turned to the ON position, the trailer ABS lamp will illuminate momentarily, then turn off.
- If the lamp illuminates momentarily during vehicle operation, then shuts off, a fault was detected and corrected.
- If the lamp illuminates and stays on during vehicle operation, there is a fault with the trailer ABS. Repair the trailer ABS system immediately to ensure full antilock braking capability.

IMPORTANT: If a compatible trailer is connected, and the lamp is not illuminating momentarily when the ignition key is turned to the ON position, it is possible that the lamp is burnt out.

Automatic Traction Control

Vehicles with electronic engines and ABS may have Automatic Traction Control (ATC). On these vehicles, the ATC system automatically limits wheel spin during reduced-traction situations. In normal braking applications, the standard air brake system is in effect.

If the vehicle has ATC, there will be a momentary-contact rocker switch on the dash labeled *Deep Mud and Snow* with an ATC icon. See [Fig. 12.4](#). Pressing

Brake Systems

the switch will temporarily allow more drive wheel spin. Pressing the switch again will cycle the system back to normal operation.

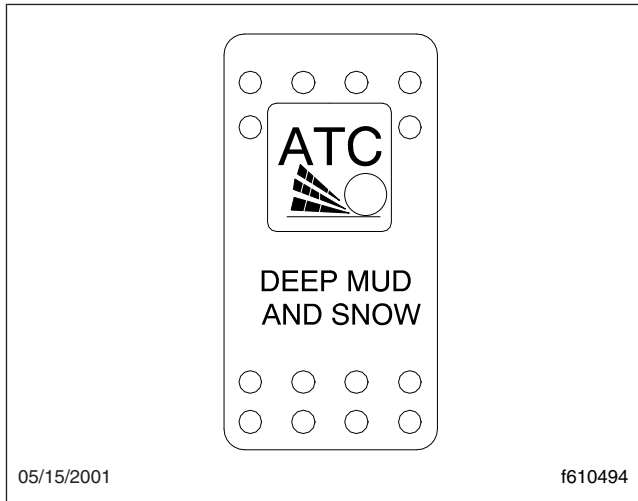

Fig. 12.4, Deep Mud and Snow Switch

An additional solenoid valve is installed. During reduced-traction situations, the ATC solenoid valve controls air pressure to the modulator valves and they in turn increase, hold, or reduce pressure to the appropriate brake chambers to provide better traction whenever wheel spin occurs.

When the ATC system is in the NORMAL mode, it will apply gentle braking to the spinning wheel, to feed power to the wheel(s) with better traction. If both wheels are spinning, the system will signal the engine to reduce power.

NOTICE

The deep snow and mud option is intended to be used under specific slippery conditions that require momentary increased wheel spin. Using this option for an extended period of time may damage the vehicle brake system.

ATC includes a deep snow and mud option to increase available traction on extra soft surfaces like snow, mud, or gravel. The activation of the deep snow and mud option is indicated by a flashing WHEEL SPIN lamp.

After the ignition switch is turned on, the tractor ABS lamp and the WHEEL SPIN indicator lamp come on for about three seconds. After three seconds, the

warning lights go out if all of the tractor's ABS components are working.

IMPORTANT: If any of the ABS warning lights do not work as described above, or come on while driving, repair the ABS immediately to ensure full antilock braking capability.

Roll-Stability Control

The roll-stability control system automatically reduces engine power, applies the engine brake, and/or applies the tractor and trailer brakes when the acceleration sensor detects that the vehicle is at risk of rolling over. The control can intervene even before an advisory message is displayed.

A decal (**Fig. 12.5**) on the auxiliary dash panel, and an amber-colored dash indicator light (**Fig. 12.6**), indicate that the vehicle is equipped with the roll-stability system components.

The dash indicator light illuminates whenever the roll-stability control system intervenes. See **Fig. 12.6**.

NOTE: The roll-stability control indicator is located on the lightbar in place of the standard WHEEL SPIN indicator.

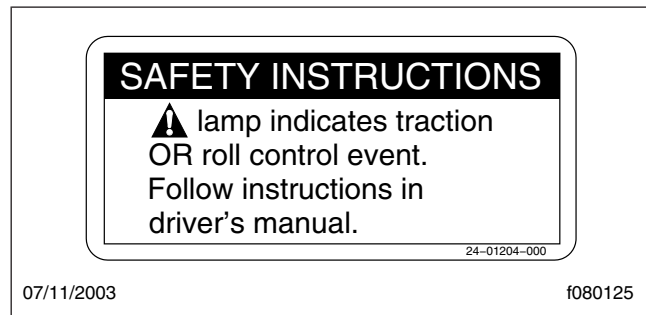

Fig. 12.5, Roll-Stability Decal



The Roll Stability Control system is intended only as an aid for a conscientious and alert driver. Carefully read the information in this manual to understand this system and its limitations. The Roll Stability Control system is not a substitute for safe driving procedures. Failure to drive safely, and use the system properly, could result in personal injury and/or death and property damage.



Fig. 12.6, Roll-Stability Indicator Lamp

13

Steering System

Power Steering System	13.1
-----------------------------	------

Steering System

Power Steering System

The power steering system includes the integral power steering gear, hydraulic hoses, power steering pump, reservoir, steering wheel and column, and other components. Some models are also equipped with a separate hydraulic power cylinder on the right side of the front axle, or a right-hand slave gear.

The power steering pump, driven by the engine, provides the power assist for the steering system. If the engine is not running, there is no power assist. If the power-assist feature does not work due to hydraulic fluid loss, steering pump damage, or some other cause, bring the vehicle to a safe stop. Do not drive the vehicle until the cause of the problem has been corrected.

WARNING

Driving the vehicle without the power-assist feature of the steering system requires much greater effort, especially in sharp turns or at low speeds, which could result in an accident and possible injury.

NOTICE

Never steam clean or high-pressure wash the steering gear. Internal damage to gear seals, and ultimately the steering gear, can result.

Drivers should carefully use the power available with a power steering system. If the front tires become lodged in a deep chuckhole or rut, drive the vehicle out instead of using the steering system to lift the tires out of the hole.

NOTICE

Avoid turning the tires when they are against a curb, as this places a heavy load on steering components and could damage them.

An optional power steering fluid cooler mounted in front of the radiator or behind the cab is available. Certain applications may limit or require the use of a power steering fluid cooler.

Steering Wheel Adjustment

When there is no load on the vehicle and the front tires are pointed straight ahead, the standard steer-

ing wheel spokes should be at the 3 o'clock and 9 o'clock positions or within 10 degrees of these positions. See [Fig. 13.1](#).

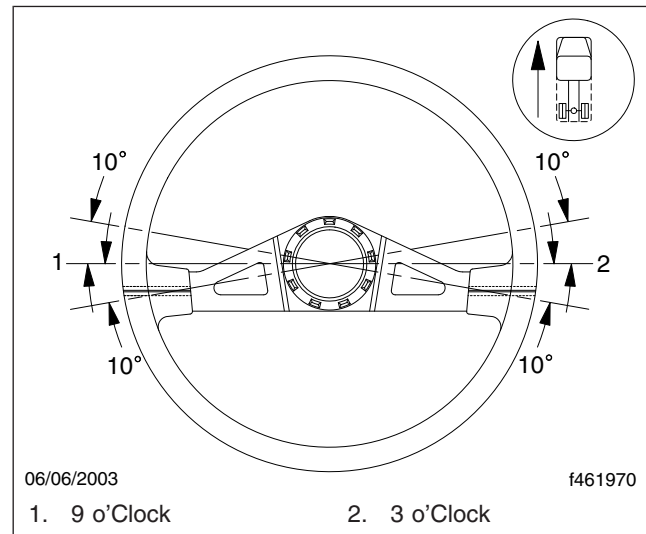

Fig. 13.1, Steering Wheel Centered

14

Manual Transmissions and Clutch

Eaton® Fuller® Transmission Operation Tips	14.1
Eaton Fuller Splitter and Range-Shift Transmissions	14.1
Eaton Fuller Deep Reduction Transmissions	14.4
Clutch	14.7

Manual Transmissions and Clutch

Eaton® Fuller® Transmission Operation Tips

Refer to the Eaton website (www.roadranger.com) for additional information.

Follow these important operation principles:

- For all conditions, use the highest gear that is still low enough to start the vehicle moving with the engine at or near idle speed, and without slipping the clutch excessively.

When operating on-highway with no load or under ideal conditions, use 1st gear to start the vehicle moving forward.

When operating off-road or under adverse conditions, use LOW gear to start the vehicle moving forward.

- Use the clutch brake to stop gear rotation when shifting into LOW or reverse while the vehicle is stationary. The clutch brake is actuated by depressing the clutch pedal all the way to the floor.
- Partially disengage the clutch to break engine torque during normal gear shifts.
- Double-clutch between all upshifts and downshifts that require movement of the shift knob. Splitting of gears does not require movement of the shift knob.
- Never push the range-preselection lever down into low range while operating in high range, except when downshifting from 5th gear to 4th gear.
- Do not shift from high range to low range at high vehicle speeds.
- Never make a range shift or a splitter shift while the vehicle is in reverse.
- Never move the range-preselection lever with the transmission in neutral while the vehicle is moving.
- Skip ratios while shifting *only* when operating conditions permit, depending on the load, grade, and road speed.
- Never coast with the transmission in neutral.

Eaton Fuller Splitter and Range-Shift Transmissions

Combination splitter and range-shift transmissions allow the choice of two splitter ratios in each gear, as well as the additional ratios provided by a low range and a high range.

General Information, Range-Shift Transmissions

IMPORTANT: Not all ratios are used in each range, and the shift patterns vary between transmissions. Read the shift pattern decal on the dash for the operating instructions for the transmission installed in your vehicle.

The range-preselection lever selects the low or high range for each transmission ratio. It is used once during an upshift sequence and once during a downshift sequence.

To operate a range-shift transmission, move the gear shift lever through all the low-range gear positions and then pull the range-preselection lever up to move into the high-range ratios.

IMPORTANT: Always preselect range shifts when upshifting or downshifting. Preselection requires that the range lever be moved to the necessary position before starting to shift. Preselecting range shifts prevents damage to the transmission and provides for smoother shifts.

General Information, Splitter Control

Dependent on the transmission model, some ratios can be split using the splitter-control button (located on the side of the gear shift lever).

IMPORTANT: Always preselect splitter shifts. Preselection requires that the splitter-control button be moved to the necessary position before starting to shift. Preselecting splitter shifts allows for smoother and faster shifting. Complete the shift immediately after preselecting the split to avoid unnecessary wear on transmission components.

Eaton Fuller 13-Speed Splitter and Range-Shift Transmissions

Eaton Fuller 13-speed transmissions have thirteen forward speeds and two reverse speeds. Each transmission consists of a 5-speed front section and a 3-speed auxiliary section. The auxiliary section contains low- and high-range ratios, plus a splitter gear. See [Fig. 14.1](#) for the shift pattern.

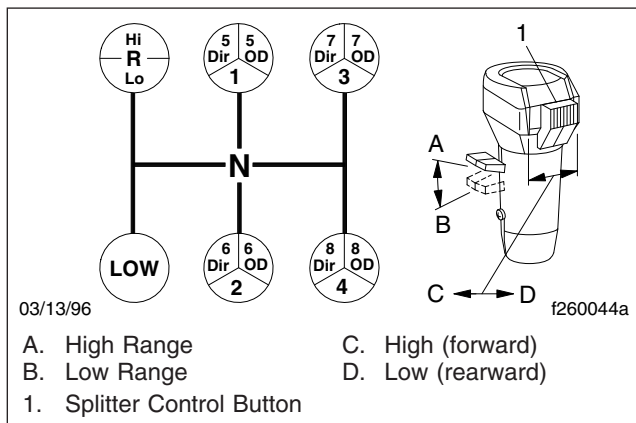

Fig. 14.1, Eaton Fuller 13-Speed Transmission Shift Pattern

LOW gear is used only as a starting gear; it is never used with the transmission in high range. The other four ratios are used once in the low range and once again in the high range.

High range gear ratios can be split by using the splitter-control button with the underdrive ratio (RT models), or overdrive ratio (RTO models). Low range gear ratios cannot be split.

Upshifting

1. Put the transmission in neutral. Start the engine and bring the air system pressure up to 100 to 120 psi (689 to 827 kPa).
2. Position the range-preselection lever down, in low range.
3. Make sure the splitter-control button is in the low (rearward) position. See [Fig. 14.1](#).
4. To start the vehicle moving, press the clutch pedal to the floor, shift into LOW or 1st gear, then engage the clutch with the engine at or near idle speed. Accelerate to 80 percent of engine governed speed.

5. Upshift from LOW (or 1st gear) through 4th gear, double-clutching when moving the gear shift lever, and accelerating to 80 percent of engine governed speed.
6. While in 4th gear, pull the range-preselection lever up into high range and move the splitter-control button to the low (rearward) position. Double-clutch into 5th gear, engage the clutch, and accelerate.
7. Upshift progressively through the high range gears.

To shift from 5th direct to 5th overdrive (or 5th underdrive to 5th direct on RT model transmissions), move the splitter-control button to the high position, then immediately release the accelerator. Press and release the clutch pedal, then, accelerate again.

Continue upshifting through the shift pattern. Double-clutch when moving the gear shift lever (6th to 7th, etc.); single-clutch during split shifts (6th direct to 6th overdrive, etc.).

Downshifting

IMPORTANT: Never use the clutch brake when downshifting, or as a brake to slow the vehicle.

1. To downshift from 8th overdrive to 8th direct (or 8th direct to 8th underdrive on RT model transmissions), move the splitter-control button to the low position, then immediately release the accelerator. Press and release the clutch pedal, then accelerate once the transmission has shifted.
2. Start the downshift from 8th direct to 7th overdrive by moving the splitter-control button to the high position, then double-clutch into 7th gear.
3. Downshift progressively through each of the high range gears, alternating the procedures in steps 1 and 2 above until reaching 5th direct.
4. When in 5th direct and ready for the downshift to 4th, push the range-preselection lever down and move the splitter-control button to the high position. Double-clutch into 4th gear, engage the clutch, and accelerate.
5. Continue downshifting from 4th gear to 1st gear, as conditions require.

Manual Transmissions and Clutch

Eaton Fuller 18-Speed Splitter and Range-Shift Transmissions

Eaton Fuller 18-speed transmissions have eighteen forward speeds and four reverse speeds. Each transmission consists of a 5-speed front section and a 4-speed auxiliary section. The auxiliary section contains low- and high-range ratios, plus a splitter gear. See [Fig. 14.2](#).

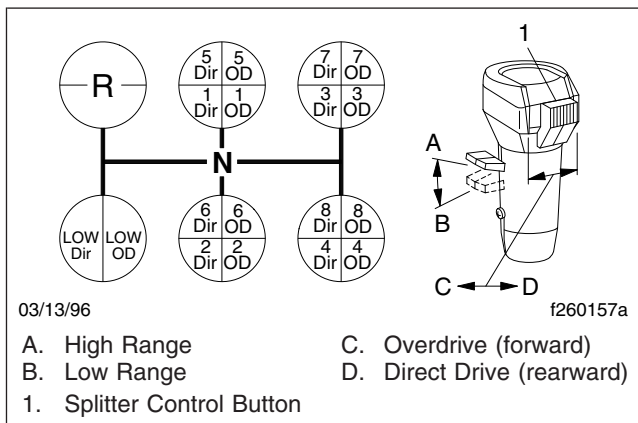

Fig. 14.2, Eaton Fuller 18-Speed Transmission Shift Pattern

LOW gear in the front section is used only as a starting gear; it is never used when the transmission is in high range. LOW gear can be split, to provide both a direct and an overdrive ratio.

Upshifting

1. Put the transmission in neutral. Start the engine and bring the air system pressure up to 100 to 120 psi (689 to 827 kPa).
2. Position the range-preselection lever down, in low range and make sure the splitter-control button is in the low position. See [Fig. 14.2](#).
3. To start the vehicle moving, press the clutch pedal to the floor, shift into LOW, then engage the clutch with the engine at or near idle speed. To shift from LOW direct to LOW overdrive, move the splitter-control button into the overdrive (forward) position, then immediately release the accelerator. Press and release the clutch pedal, and accelerate.
4. Upshift from LOW overdrive to 1st direct by first moving the splitter-control button into the direct

drive (rearward) position ([Fig. 14.2](#)). Double-clutch into 1st gear.

Continue upshifting through the shift pattern. Double-clutch when moving the gear shift lever (1st to 2nd to 3rd to 4th); single-clutch during split shifts (1st direct to 1st overdrive, etc.).

5. When in 4th overdrive, use the range-preselection lever and the splitter-control button to upshift to 5th gear.

While in 4th gear, pull the range-preselection lever up into high range and move the splitter-control button to the low position. Double-clutch into 5th gear, engage the clutch, and accelerate.

6. Upshift progressively through the high range gears.

To shift from 5th direct to 5th overdrive (or 5th underdrive to 5th direct on RT model transmissions), move the splitter-control button to the high position, then immediately release the accelerator. Press and release the clutch pedal, and accelerate.

Continue upshifting through the shift pattern. Double-clutch when moving the gear shift lever (6th to 7th, etc.); single-clutch during split shifts (6th direct to 6th overdrive, etc.).

Downshifting

IMPORTANT: Never use the clutch brake when downshifting, or as a brake to slow the vehicle.

1. To downshift from 8th overdrive to 8th direct (or 8th direct to 8th underdrive on RT model transmissions), move the splitter-control button to the low position, then immediately release the accelerator. Press and release the clutch pedal, then accelerate once the transmission has shifted.
2. Start the downshift from 8th direct to 7th overdrive by moving the splitter-control button to the high position, then immediately double-clutch into 7th gear.
3. Downshift progressively through each of the high range gears, alternating the procedures in steps 1 and 2 above until reaching 5th direct.
4. When in 4th overdrive, push the range-preselection lever down and move the splitter-control button to the high position. Double-clutch

Manual Transmissions and Clutch

through into 4th gear, engage the clutch, and accelerate.

- Continue downshifting from 4th overdrive to 4th direct, then 4th direct to 3rd overdrive, etc. Double-clutch when moving the gear shift lever (4th to 3th, etc.); single-clutch during split shifts (4th direct to 3rd overdrive, etc.).

Eaton Fuller 10-Speed Range-Shift Transmissions

Eaton Fuller 10-speed transmissions have ten selective, evenly-spaced forward ratios. Each transmission consists of a 5-speed front section, and a 2-speed auxiliary section. The ten forward speeds are obtained by twice using a 5-speed shift pattern: the first time in low range, the second time in high range. See Fig. 14.3 for the shift patterns, noting that the 4th/9th and the 5th/10th shift positions in the RT (direct ratio) transmissions are directly opposite in the RTO (overdrive ratio) transmissions.

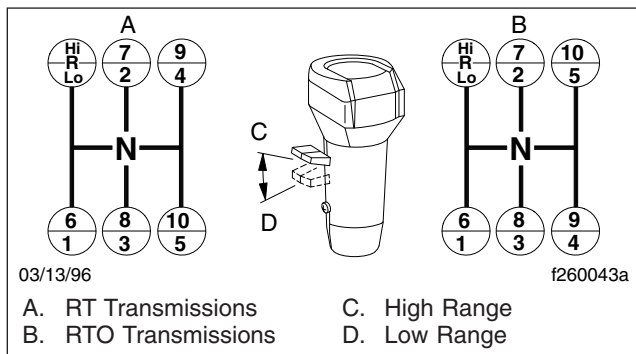

Fig. 14.3, Eaton Fuller 10-Speed RT and RTO Transmissions Shift Patterns

Upshifting

- Put the transmission in neutral. Start the engine and bring the air system pressure up to 100 to 120 psi (689 to 827 kPa).
- Position the range-preselection lever down, in low range.
- To start the vehicle moving, press the clutch pedal to the floor; shift into 1st gear, then engage the clutch with the engine at or near idle speed. Accelerate to 80 percent of engine governed speed.

- Upshift progressively from 1st gear through 5th gear, double-clutching when moving the gear shift lever.
- When in 5th gear and ready to move to 6th gear, pull the range-preselection lever up into the high range. Double-clutch into 6th gear, engage the clutch, and accelerate.

NOTE: If after attempting to shift into the high range the transmission remains in neutral, the range synchronizer protection device may be activated. Move the gear shift lever to neutral to allow the range shift to complete, then shift back into gear.

- Upshift progressively through the high range gears, double-clutching when moving the gear shift lever and accelerating to 80 percent of engine governed speed.

Downshifting

IMPORTANT: Never use the clutch brake when downshifting, or as a brake to slow the vehicle.

- Downshift progressively through each of the high range gears, double-clutching between shifts.
- When in 5th gear and ready to move to 4th gear, push the range-preselection lever down into the low range. Double-clutch into 4th gear, engage the clutch, and accelerate.
- Downshift progressively through the low range gears, double-clutching when moving the gear shift lever, as conditions require.

Eaton Fuller Deep Reduction Transmissions

General Information

Eaton Fuller 10-speed deep reduction transmissions have a 5-speed front section, and a 2-speed auxiliary section, with a deep reduction gear. The low-low, deep reduction gear is used only when operating under adverse conditions. Low gear in the front section is used only for rough, off-highway conditions, as a starting ratio. The remaining four forward positions are used once in the low range and once in the high range. See Fig. 14.4 for the shift pattern, noting that the 3rd/7th and 4th/8th shift positions in RT-LL transmissions are opposite of the RTO-LL transmissions.

Manual Transmissions and Clutch

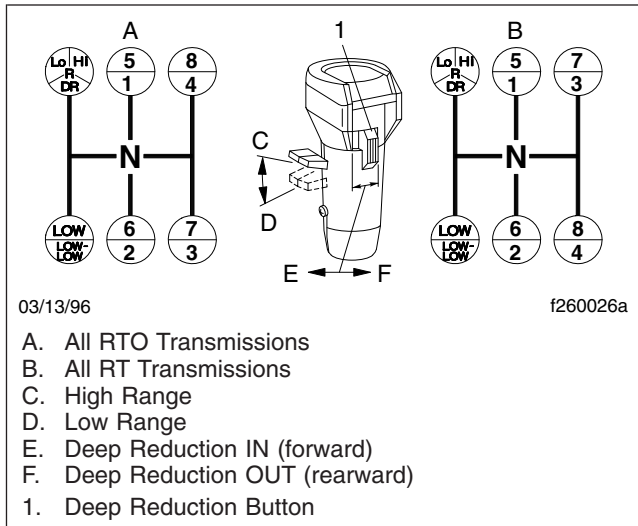

Fig. 14.4, Eaton Fuller 10-Speed Deep Reduction Shift Patterns

Eaton Fuller 15-speed deep reduction transmissions have a 5-speed front section, and a 2-speed auxiliary section. They also have five additional deep reduction ratios. The 5-speed front section and the low and high range sections provide ten evenly and progressively spaced forward speeds. The five deep reduction ratios are also evenly and progressively spaced; however, they do overlap the low range ratios, and should be used only when operating under adverse conditions. See Fig. 14.5 for the shift patterns, noting that the 4th/9th, and the 5th/10th shift positions in RT (direct ratio) transmissions are directly opposite to the RTO (overdrive ratio) positions.

Use the following tips when shifting:

- Use the clutch brake to stop gear rotation when shifting into low-low, low-1st (whichever is used as a starting ratio) or reverse, when the vehicle is stationary.
- For normal upshifts and downshifts, only a partial disengagement of the clutch is necessary to break engine torque.
- When making the shift from a deep reduction ratio to a low range ratio, move the deep reduction button from a forward position to a rearward position, then complete the shift immediately.

- Never move the deep reduction button from a rearward position to a forward position when the transmission is in high range.
- Deep reduction gears are best suited for heavy loads and steep inclines.

Upshifting Deep Reduction Transmissions

There are several patterns of upshifting, depending on the vehicle load and the road conditions. See [Table 14.1](#) for suggested shifting sequences.

The following instructions are recommended for starting a loaded vehicle moving under adverse conditions.

1. Put the transmission in neutral. Start the engine, and bring the vehicle air system pressure up to 100 to 120 psi (689 to 827 kPa).
2. Position the range preselection lever down, into low range.
3. Move the deep reduction button to the forward position, to engage the deep reduction gears.
4. Depress the clutch pedal to the floor; shift into low-low gear (10-speed transmissions) or 1st gear of deep reduction (15-speed transmissions); then engage the clutch, with the engine at or near idle speed, to start the vehicle moving. Accelerate to 80 percent of engine governed speed.
5. For 10-speed transmissions:
 When ready for the next upshift, move the deep reduction button rearward, then momentarily depress the clutch pedal. Do not move the shift lever.

For 15-speed transmissions:

Shift upward from 1st gear of deep reduction to 5th gear of deep reduction, double-clutching between shifts and accelerating to 80 percent of engine governed speed. See [Table 14.1](#).

When ready for the next upshift, move the deep reduction button rearward, then double-clutch into 4th gear.

Manual Transmissions and Clutch

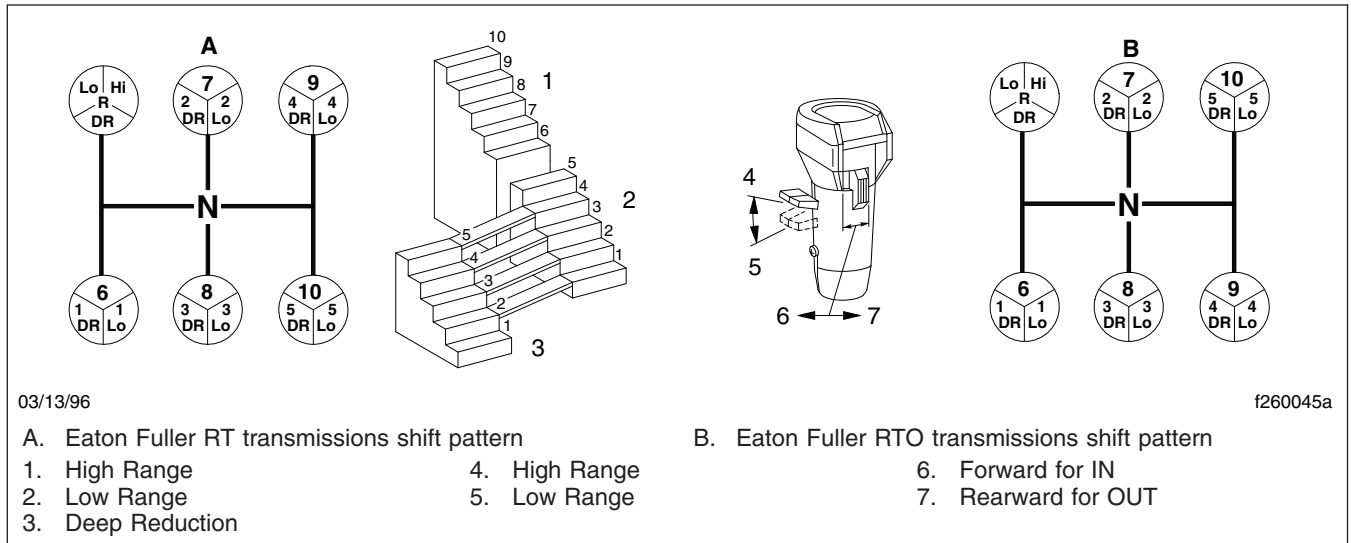

Fig. 14.5, Eaton Fuller 15-Speed Model Shift Patterns

Eaton Fuller Shift Progressions				
Transmission Model	Deep Reduction	Low Range		High Range
	Adverse Conditions Only	Off-Highway and Adverse Conditions	On-Highway and Ideal Conditions	All Conditions
10-Speed RTO				
10-Speed RT				
15-Speed RTO				
15-Speed RT				

Table 14.1, Eaton Fuller Shift Progressions

6. Shift upward from low gear (10-speed transmissions) or 4th gear (15-speed transmissions), to the top gear in low range (see [Table 14.1](#)),

double-clutching between shifts, and accelerating to 80 percent of engine governed speed.

Manual Transmissions and Clutch

7. While in the top gear of the low-range shift pattern, flip the range preselection lever up. Double-clutch into the bottom gear in high range (see [Table 14.1](#)).
8. With the transmission in high range, shift progressively upward through each of the high range gears (see [Table 14.1](#)), double-clutching between shifts.

Downshifting Deep Reduction Transmissions

1. With the transmission in high range, shift progressively downward to the bottom gear in high range, double-clutching between shifts.
2. When in the bottom gear of the high-range shift pattern, push the range preselection lever down. Double-clutch into the top gear of the low-range shift pattern.

IMPORTANT: Never move the deep reduction button to a forward position when the transmission is in high range.

3. With the transmission in low range, downshift through the low range gears, as conditions require.

Clutch

Clutch General Information

To ensure long service life of the clutch, start in the right gear, be alert to clutch malfunctions, and know when to adjust the clutch.

Typical operation will not break down the clutch friction surfaces. Heat and wear are almost nonexistent when a clutch is fully engaged. However, during the moment of engagement, when the clutch is picking up the load, considerable heat is generated. If a clutch slips excessively, high temperatures develop quickly between the flywheel, driven discs, and pressure plates. An improperly adjusted or slipping clutch can generate temperatures high enough to destroy the clutch.

Clutch Operation

Clutch Break-In

The clutch may slip for a short time while the friction surfaces break-in on a new or newly-installed clutch.

NOTICE

Do not allow the clutch to slip longer than two seconds. Clutch slippage for longer than two seconds may severely damage the clutch disc, pressure plate, or flywheel. Damage caused by clutch slippage due to improper break-in is not warrantable.

During initial operation of a new vehicle or a vehicle with a new clutch, check for clutch slippage during acceleration. If the clutch slips, decelerate until the clutch does not slip. Allow the clutch to cool 15 to 30 seconds, then gradually accelerate again. If the clutch continues to slip, repeat the procedure as many as five times. If the clutch slips after five attempts, stop the vehicle and allow the clutch to cool for at least one hour. Notify your Western Star dealer of the problem.

Moving the Vehicle in the Proper Gear

An empty vehicle can be started in a higher gear than can a partially- or fully-loaded vehicle. Select the gear combination that allows the vehicle to start moving with an idling engine or, if necessary, just enough throttle to prevent stalling the engine.

Gear Shifting Techniques

Upshift into a higher gear only when the vehicle speed allows the transmission input shaft speed to match the flywheel speed when engaging the clutch. This technique results in the smallest speed difference between the clutch disc and the flywheel, and causes the least heat and wear on the clutch assembly. When downshifting, increase the input shaft speed to match the flywheel by slightly revving the engine.

Vehicle Loading

Clutches are designed for specific vehicle applications and loads.

NOTICE

Exceeding vehicle load limits can result in damage to the clutch and the entire powertrain.

Manual Transmissions and Clutch

Clutch Brake

Apply the clutch brake by depressing the clutch pedal all the way to the floor plate. The last part of pedal travel will compress the clutch brake plates together, stopping the transmission input shaft. The clutch brake stops the transmission gears from rotating in order to quickly engage a transmission gear after idling in neutral.

NOTICE

Never apply the clutch brake when making downshifts or upshifts. If the clutch brake is applied when the vehicle is moving, the clutch brake will try to stop or decelerate the vehicle, causing rapid wear of the clutch brake friction discs. Considerable heat will be generated, causing damage to the release bearings and the transmission front bearings.

Using the Clutch

Use the clutch pedal only when starting the engine, launching the vehicle from a stop, or shifting. To launch a stationary vehicle, depress the clutch pedal all the way to the floor plate (see **Clutch Brake** above) and shift from neutral to a low gear. Slowly raise your foot until the clutch starts to engage. In this position the clutch is starting to connect the transmission input shaft to the flywheel and is causing the most heat and wear. Slightly increase the engine speed and smoothly allow the clutch pedal to return to the rest position. Do not allow the clutch to remain in the partially-engaged position any longer than necessary to obtain a smooth start.

Double-clutch to shift gears while the vehicle is moving. Depress the clutch pedal most of the way in, but not all the way to the floor plate. Depressing the clutch pedal to the floor plate will engage the clutch brake. Shift the transmission into neutral and fully release the clutch pedal. When upshifting, wait for the engine speed to decrease to the road speed. When downshifting, increase the engine speed to match the road speed. Fully release the clutch pedal after completing the shift.

NOTICE

Riding the clutch while driving is damaging to the clutch because partial clutch engagement causes slippage and heat. Resting your foot on

the clutch pedal will also put a constant thrust load on the release bearing, thinning the bearing lubricant and increasing the wear on the bearing.

Holding the Vehicle On an Incline

Always use the vehicle service brakes to prevent the vehicle from rolling backwards while stopped on a hill. Slipping the clutch on a hill to maintain vehicle position will quickly damage the clutch assembly.

Coasting

Coasting with the clutch pedal depressed and the transmission in a low gear can cause high driven disc speed. The clutch speed can be much higher under these conditions than when the engine is driving the clutch. This condition creates a hazardous situation due to the lack of vehicle control and due to the high clutch disc speed. Engaging the clutch under these conditions can cause component damage because of the shock loads to the clutch and drivetrain.



Always shift into the gear that is correct for the traveling speed of the vehicle and engage the clutch. Coasting with the clutch disengaged can prevent engagement of the correct transmission gear which can cause loss of vehicle control, possibly resulting in personal injury or property damage.

High clutch disc speeds while coasting can also cause the clutch facing to be thrown off the disc. Flying debris from the clutch can cause injury to persons in the cab.

Clutch Maintenance

Checking the Clutch Adjustment

Report erratic clutch operation as soon as possible to give maintenance personnel a chance to inspect, lubricate, and adjust the clutch components. Notice any gradual decrease in the distance the clutch pedal moves before resistance is felt.

NOTICE

Operating the vehicle with incorrect free pedal could result in clutch damage.

Manual Transmissions and Clutch

A correctly adjusted clutch must have about 3/4 inch (19 mm) of travel at the top of its stroke before a stronger resistance can be felt. See **Fig. 14.6**. If the free pedal travel is less than this distance, have the clutch adjusted.

Check the clutch free pedal travel daily and note it in the driver's report.

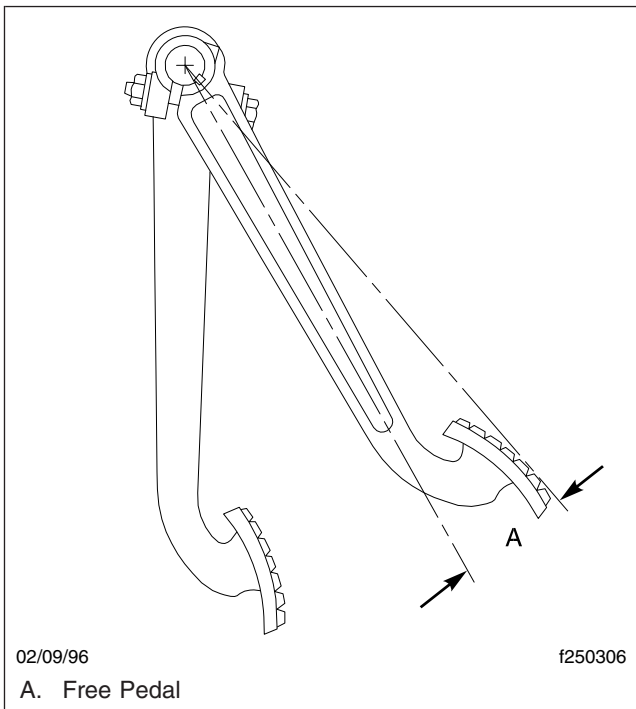

Fig. 14.6, Clutch Free Pedal Travel

Adjusting the Clutch

Clutches have an internal adjustment and external linkage adjustment. See **Group 25** of the *Western Star Workshop Manual* for clutch adjustment procedures and specifications.

NOTICE

Operating the vehicle with the clutch improperly adjusted could result in clutch or clutch brake failure.

Checking the Clutch Brake Operation

Clutch brake operation can be felt as an increased resistance as the clutch pedal approaches the bottom of its stroke. If the gears grind when shifting into

first or reverse gear from neutral with the clutch pedal fully depressed, the clutch pedal is out of adjustment or the clutch brake is worn and needs to be replaced.

Lubricating the Clutch Release Bearing

NOTICE

Failure to lubricate the release bearing and linkage as recommended could result in release bearing and clutch damage.

On vehicles equipped with a greaseable release bearing, the release bearing should be lubricated at regular intervals. See the *Western Star Maintenance Manual* for intervals and procedures.

15

Automated and Automatic Transmissions

Eaton® Fuller® Automated Transmissions	15.1
Allison Automatic Transmissions	15.5

Automated and Automatic Transmissions

Eaton® Fuller® Automated Transmissions

Refer to the Eaton website (www.roadranger.com) for additional information.

General Information, Automated Transmissions

The Eaton Fuller UltraShift is a heavy-duty fully automated transmission. The UltraShift uses a dry clutch system, so no clutch pedal is required to shift gears.

The Eaton Fuller AutoShift transmission requires the driver to use the clutch to start and stop the vehicle. However, the driver does not need to use the clutch to shift gears.

The Eaton Fuller automated transmissions use a shift selection module located on the dash control panel. See **Fig. 15.1**. Shifts can be made automatically, or manually using the shift selection module.

The current gear is displayed on the indicator shown in **Fig. 15.2**. At the start of a shift, the current gear continues to display until the transmission has been pulled into neutral. As the transmission is synchronizing for the new (target) gear, the gear indicator flashes the number of the target gear. When the shift is complete, the gear indicator displays the new gear, without flashing.

Automated Transmission Operation

Modes

The shift selection module controls the driving mode, which includes drive, manual, reverse, or low.

IMPORTANT: In all modes but low, it is possible to shift manually by pressing the upshift or downshift selectors as needed. When the engine speed is within 75 rpm of the load-based shift point for an automatic shift, the transmission will advance the shift.

Drive Mode

Press the drive mode button (D) on the shift selection module to put the transmission in drive mode.

In drive mode, upshifts and downshifts are made by the transmission without driver intervention. The transmission will shift automatically when the driver

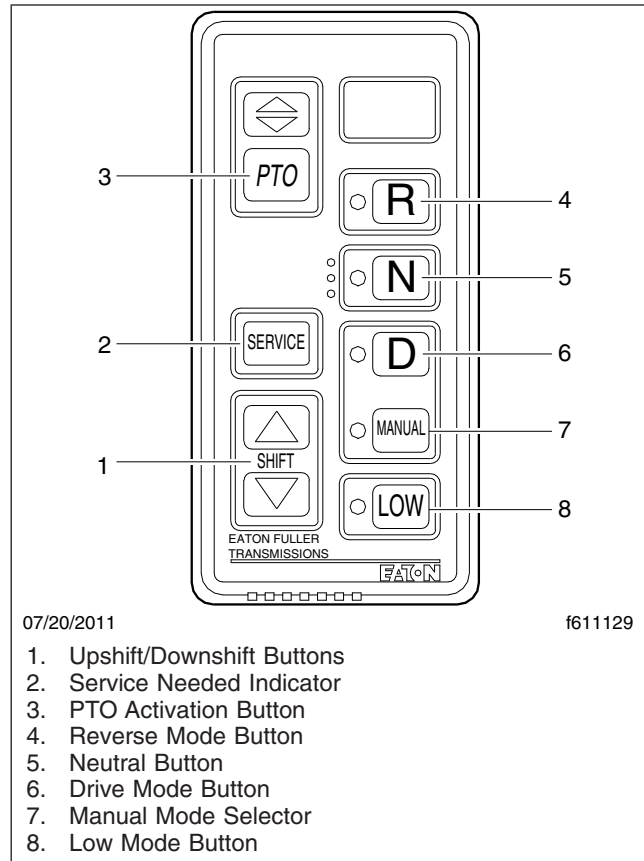

Fig. 15.1, Shift Selection Module, UltraShift and AutoShift Transmissions

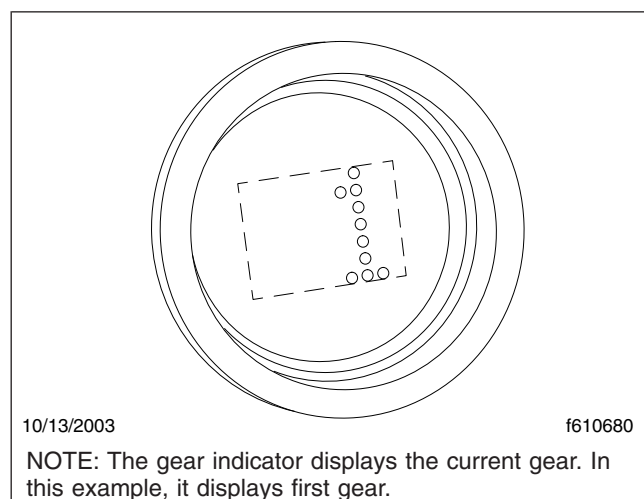

Fig. 15.2, Gear Indicator

Automated and Automatic Transmissions

presses the drive mode button (D) and depresses the accelerator pedal.

If driving conditions require, it is still possible to request a manual shift. The transmission will make the shift if the engine speed is within 75 rpm of the load-based shift point for that gear.

If the vehicle is stopped while in drive mode, the upshift/downshift buttons can be used to change the starting gear. This selection becomes the default starting gear until it is changed by the driver again, or the vehicle is shut down.

The transmission controller adapts to the working conditions of each vehicle and its driver. After power-up or a load change, it needs to learn the new conditions. While learning, it may hold a gear too long before upshifting. If this occurs, start the upshift manually. It may take three or four shifts before the transmission succeeds in learning the new load-based shift points, but after that it will handle the shifting automatically.

Automatic skip shifts may occur in drive mode if conditions are appropriate.

Manual Mode

In manual mode, upshifts and downshifts are made by the driver. This allows the driver to respond to a wide range of driving conditions, such as blind corners, tight curves, and steep hills.

To change to manual mode, press the manual mode button (MANUAL) on the shift selection module. If manual mode is selected while the vehicle is moving, the current gear will be maintained until the driver requests a shift using the proper upshift/downshift arrow button. If the manual mode is selected while the vehicle is not moving, the starting gear will be maintained until the driver requests a shift. In downhill situations in particular, the driver must be alert to vehicle speed by downshifting and/or using the service brakes as needed. A shift request will be refused if the selected gear would cause engine overspeed or excessive lugging.

To upshift, press the upshift arrow button on the shift selection module; to downshift, press the downshift arrow button. See [Fig. 15.1](#). A shift request will be refused if the selected gear would cause engine overspeed or excessive lugging.

Reverse Mode

To put the transmission in reverse, press the reverse mode button on the shift selection module.

The UltraShift transmission has two reverse gears: reverse low and reverse high. The AutoShift transmission may have multiple reverse gears. To shift manually between the reverse gears, press the upshift or downshift arrow button until the desired reverse gear is displayed.

Reverse low is the default reverse gear. When reverse low is selected, the letter R displays on the gear indicator. See [Fig. 15.3](#). When reverse high is selected, the letter H is displayed.

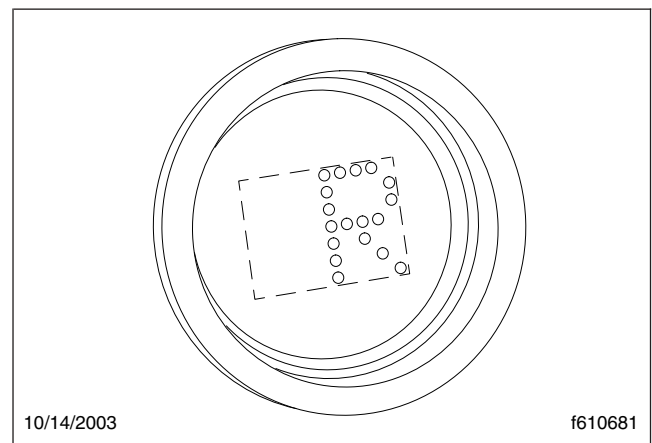

Fig. 15.3, Gear Indicator: Reverse Low Gear

IMPORTANT: Under normal conditions, do not select reverse with the vehicle moving forward.

The vehicle must be moving at less than two miles per hour (3 km/h) before selecting reverse. If reverse is selected when the vehicle is moving faster, an audible alert will sound and continue sounding at three-second intervals until the vehicle slows to the proper speed or the driver selects the drive mode.

Low Mode

Low mode should be used to maximize engine braking and minimize the use of the brake pedal. It is most useful when descending steep hills or when coming to a stop. Engine speed will be increased by 200 rpm and shift points will be offset by 200 rpm.

To select low mode, press the low mode button (LOW) on the shift selection module. When in low,

Automated and Automatic Transmissions

the current gear is maintained. Requests to upshift are not enabled.

IMPORTANT: If the engine is approaching overspeed, the transmission controller will override the current gear setting and upshift to prevent engine damage.

If low mode is selected from neutral while the vehicle is stopped, the vehicle will start up in first gear and stay there until the engine approaches overspeed.

Neutral

IMPORTANT: Always start the engine with the transmission in neutral (N) and the parking brake set.

WARNING

Do not coast in neutral. Coasting in neutral can cause an accident, possibly resulting in severe personal injury or death.

Neutral is always available during operation, whatever the vehicle speed. When in neutral, requests to upshift or downshift are ignored. If the driver selects drive mode while the vehicle is moving in neutral, the transmission will shift into the appropriate gear given the engine speed.

When shifting from neutral, always depress the brake pedal. If the brake pedal is not depressed, the transmission will not shift and an audible alert will sound. To reset the transmission, select neutral again and attempt the shift again, this time with the brake pedal depressed.

Before shutting down the engine, return the transmission to neutral.

Powering Up

1. With the parking brake set, turn the ignition switch on and allow the shift selection module to power up. The gear indicator will show the dot display, arranged in a square pattern. All dots in the pattern should light up, without gaps or spaces. See [Fig. 15.4](#).
2. Wait for the gear indicator to show a solid N. See [Fig. 15.5](#). When the N is solid (not flashing), the transmission controller is powered up.

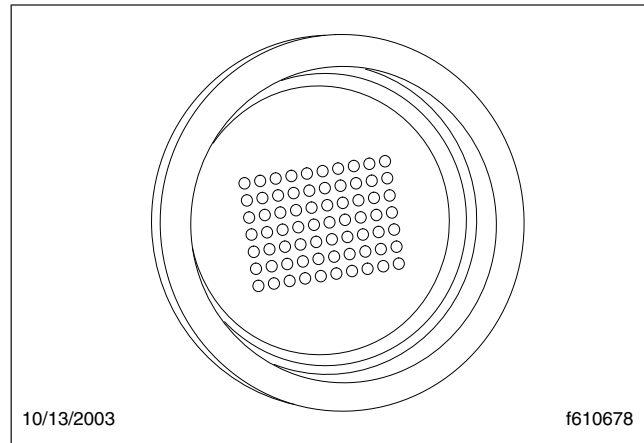

Fig. 15.4, Gear Indicator: Power Up Dot Display

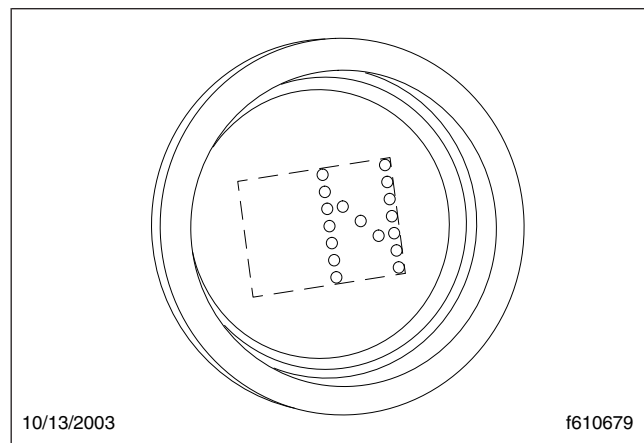

Fig. 15.5, Gear Indicator: Neutral

3. On vehicles with an AutoShift transmission, depress the clutch pedal all the way to the floor.
4. Apply the service brake and start the engine.
5. On vehicles with an AutoShift transmission, release the clutch to allow the speed sensor on the input shaft to get a reading, then depress the clutch pedal again.

NOTE: When in drive mode, the transmission defaults to second gear when starting off. If desired, the driver can select to start off in first gear. No other start gear is available.

6. Select the desired mode (drive, manual, low, or reverse), then select the desired starting gear.

Automated and Automatic Transmissions

WARNING

When starting or stopping on hills and grades, use extra care to prevent the vehicle from rolling back. A rollback accident could cause death, serious personal injury, or property damage.

7. On a level grade, release the parking and service brakes.
8. Move the vehicle forward by doing one of the following:
 - *Vehicles with an UltraShift transmission:* depress the accelerator pedal.
 - *Vehicles with an AutoShift transmission:* release the clutch and depress the accelerator pedal.

Powering Down

1. On vehicles equipped with an AutoShift transmission, depress the clutch pedal to the floor.
2. Bring the vehicle to a halt
3. Apply the service brakes.
4. Select neutral (N) on the shift selection module. When the N on the gear indicator is solid (not flashing), the transmission controller is ready to power down.
5. Set the parking brake and shut down the engine.

Upshifting

To request an upshift, push the upshift arrow button on the shift selection module. If the gear is available, the transmission will upshift and the new gear will display on the gear indicator. If the gear requested is unavailable, a tone will sound.

Upshifts are not available in low mode, except to prevent engine overspeed.

NOTE: The AutoShift transmission is able to perform triple upshifts when the next three higher gears are available and conditions are appropriate.

Skip shifts can be performed only in manual mode. To skip shift, press the upshift button twice or three times. The number of the gear engaged will appear on the gear indicator.

Downshifting

To request a downshift, push the downshift arrow button on the shift selection module. If the gear is available, the transmission will downshift and the new gear will display on the gear indicator. If the gear requested is unavailable, a tone will sound.

Before starting down a hill, downshift to a speed that you can control without hard pressure on the service brakes. Before entering a curve, downshift if necessary. This lets you use some power through the curve to help the vehicle be more stable in the turn. It also allows you to regain speed faster as you come out of the curve.

NOTE: The AutoShift transmission is able to perform triple downshifts when the next three lower gears are available and conditions are appropriate.

Skip shifts can be performed only in manual mode. To skip shift, press the downshift button twice or three times. The number of the gear engaged will appear on the gear indicator.

For best engine braking, select low mode while moving. In low, downshifts are performed at higher rpm than in drive.

IMPORTANT: If the engine is approaching overspeed, the transmission controller will override the current gear setting and upshift to prevent engine damage.

Transmission Diagnostics

Clutch Protection Fault, UltraShift Transmissions

Even though a vehicle with an UltraShift transmission does not have a clutch pedal, it does have a mechanical clutch. As you slowly increase and decrease engine rpm from a stop, the mechanical clutch is engaging and disengaging, just like slipping the clutch with a manual transmission. Excessive clutch slippage creates heat and reduces the life of the clutch. Conditions that can cause clutch damage include:

- Using the accelerator pedal to hold the vehicle on a hill
- Starting the vehicle from a stop in a gear that's too high
- Overloading the vehicle

Automated and Automatic Transmissions

- Using high idle with the vehicle in gear

The transmission controller is programmed to prevent clutch damage. When the clutch overheats, the following alerts take place:

- The TRANS TEMP light comes on
- The gear indicator displays "C," then "A"
- A warning tone sounds at one-second intervals

The alerts continue until the clutch cools, the accelerator pedal is released, or the clutch is fully engaged.

System Problem

In the event of a problem, complete the following steps.

1. Note the driving conditions at the time the problem occurred.
2. Record the status of the transmission at the time of the problem (current mode, current gear, engine speed, etc.).
3. Complete the transmission reset procedure.

Transmission Reset Procedure

In some cases, proper transmission operation can be restored by resetting the transmission controller.

1. When it is safe to do so, stop the vehicle.
2. Select neutral by pressing the neutral button (N) on the shift selection module.
3. Set the parking brake.
4. Shut down the engine.
5. Wait at least two minutes.
6. Restart the engine.
7. If the problem continues or the transmission doesn't achieve neutral after power-up, contact an authorized Western Star or Eaton service facility.

Locked In Gear

If the vehicle is shut down while in gear, the transmission may become locked in gear. The transmission will attempt to get to neutral during the next power-up if neutral is selected on the shift selection module. If neutral can't be achieved, a dash (–) will

appear on the gear indicator when the vehicle is restarted.

Complete the following steps.

1. Set the parking brake.
2. Turn off the ignition and wait at least two minutes.
3. Depress the brake pedal and release the parking brake.
4. On vehicles with an AutoShift transmission, depress the clutch partway to the floor.
5. Select neutral by pressing the neutral button (N) on the shift selection module, then turn on the ignition key. Do not attempt to start the engine yet.
6. Release the pressure on the brake pedal slightly.
7. Once the transmission is in neutral, a solid N will appear on the gear indicator and the vehicle will start. Apply the service brakes and start the engine.
8. If the gear indicator continues to display a dash, contact an authorized Western Star or Eaton service facility.

Allison Automatic Transmissions

Refer to the Allison website for additional information (www.allisontransmission.com).

General Information, Allison Transmissions

HD-series automatic transmissions have six forward speeds and one reverse speed. These transmissions have electronic shift controls that can be programmed to allow the use of different numbers of geared speeds. For instance, the transmission can be programmed to operate as a 4-speed, 5-speed, or 6-speed unit in the "primary" shift mode. If needed, a "secondary" shift mode can be programmed to provide another shift configuration to optimize vehicle use under different operating conditions.

To activate a secondary shift mode, or other special functions programmed into the electronic control unit (ECU), press the Mode button. See **Fig. 15.6**. "MODE ON" is displayed in the indicator panel just

Automated and Automatic Transmissions

above the push buttons. A label just above the Mode button identifies the special function.

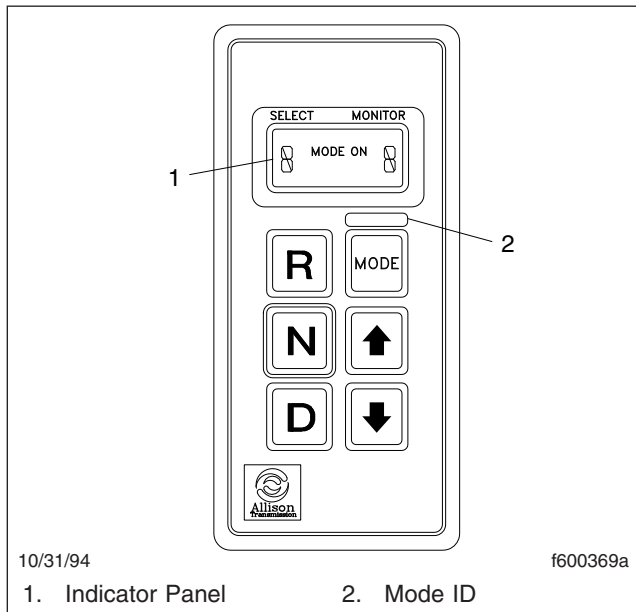

Fig. 15.6, Allison Push Button Shift Selector

NOTE: Each time a button is pressed on the shift selector, a short beep will be heard. This indicates that the ECU has received input to change operation.

The HD-series transmission is designed to warn the driver of transmission malfunctions. The driver should know the extent of the warning system in order to safely operate the vehicle.

Allison Transmission Operation

WARNING

Never shift from neutral (N) to drive (D) or reverse (R) at engine speeds above idle. The vehicle will lurch forward or backward, which could cause property damage and personal injury.

NOTICE

The engine should never be operated for more than thirty seconds at full throttle with the transmission in gear and the output stalled. Prolonged operation of this type will overheat the transmis-

sion fluid and will result in severe damage to the transmission.

NOTICE

Do not allow the vehicle to coast in neutral. This can result in severe transmission damage.

The following tips highlight important operation principles.

- Start the engine, then check the digital display on the shift selector. Under "Select" at the top of the unit, the display should always show the "primary" shift mode. Under "Monitor," the current gear should be displayed.
- Use reverse to back the vehicle. Completely stop the vehicle before shifting from a forward gear to reverse, or from reverse to forward. There is only one reverse gear.
- Select drive (D) for all normal driving conditions. The vehicle will start out in 1st gear, and as speed increases, the transmission will upshift through each gear automatically. As the vehicle slows down, the transmission will downshift automatically.
- The pressure of your foot on the accelerator pedal influences the automatic shifting. When the pedal is fully depressed, the transmission will automatically upshift near the governed speed of the engine. A partially depressed pedal will cause the upshifts to occur at a lower engine speed.
- Occasionally the road, load, or traffic conditions make it desirable to restrict the automatic shifting to a lower range. The lower the gear range, the greater the engine braking power.

Use the up or down buttons on the shift selector to reach the desired gear. The "SELECT" indicator will display your choice, and the "MONITOR" indicator will show the selected gear once it is reached. In the lower gear ranges, the transmission will not upshift above the highest gear selected unless the engine governed speed is exceeded.

- Use neutral and apply the parking brake when the vehicle is parked with the engine running.

16

Drive Axles

Drive Axles with Differential Lock	16.1
Interaxle Lock	16.2

Drive Axles

Drive Axles with Differential Lock

The driver-controlled differential lock feature (side-to-side wheel lock, traction control, or traction equalizer) provides maximum traction for slippery conditions by forcing the wheels on each drive axle governed by the switch to rotate together. When the differential lock is engaged, the clutch collar completely locks the differential case, gearing, and axle shafts together, maximizing the traction of both wheels.

Differential Lock Switch

There are several differential lock options available:

- a switch to control the differential lock on the forward drive axle (see [Fig. 16.1](#)).

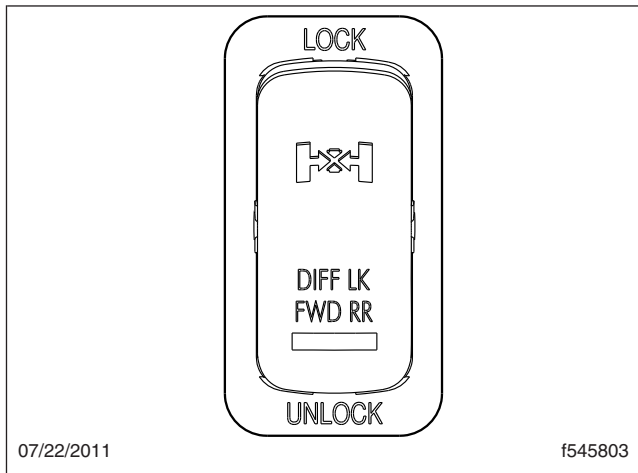

Fig. 16.1, Forward Drive Axle Differential Lock Switch

- a switch to control the differential lock on the middle drive axle.
- a switch to control the differential lock on the rear drive axle (see [Fig. 16.2](#)).

Differential Lock Operation

NOTE: On some vehicles, the differential lock system is connected through the low speed range of the transmission. If this system is used, the transmission must be in the low speed range for the wheels to fully lock. In addition, shifting out of low speed range will also disengage the differential lock.

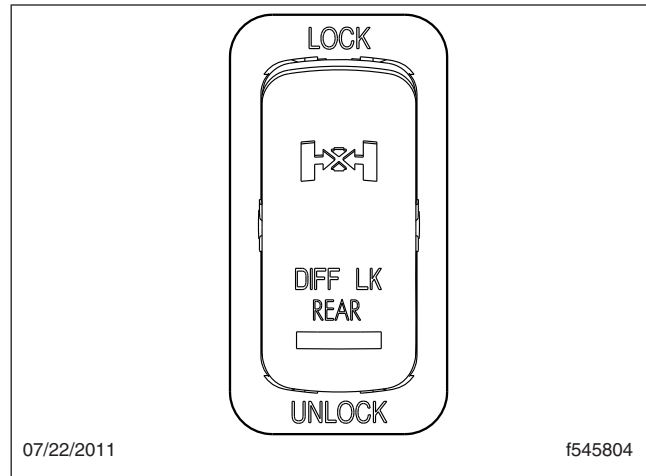

Fig. 16.2, Rear Drive Axle Differential Lock Switch

WARNING

Locking the wheels when the vehicle is traveling down steep grades or when the wheels are slipping could damage the differential and/or lead to loss of vehicle control, causing personal injury and property damage.

NOTICE

Engage the differential lock only when the vehicle is stopped or moving at less than 5 mph (8 km/h). Engaging the differential lock at high speeds can cause internal axle damage.

1. With the engine running, press the upper half of the differential lock switch to engage the differential lock.
2. If the vehicle is moving, briefly let up on the accelerator to relieve torque on the gearing, allowing the differential to fully lock.

WARNING

Be especially careful when driving under slippery conditions with the differential locked. Though forward traction is improved, the vehicle can still slip sideways, causing possible loss of vehicle control, personal injury, and property damage.

3. Drive cautiously and do not exceed 25 mph (40 km/h). When the differential is fully locked, the

turning radius will increase because the vehicle understeers. See **Fig. 16.3**.

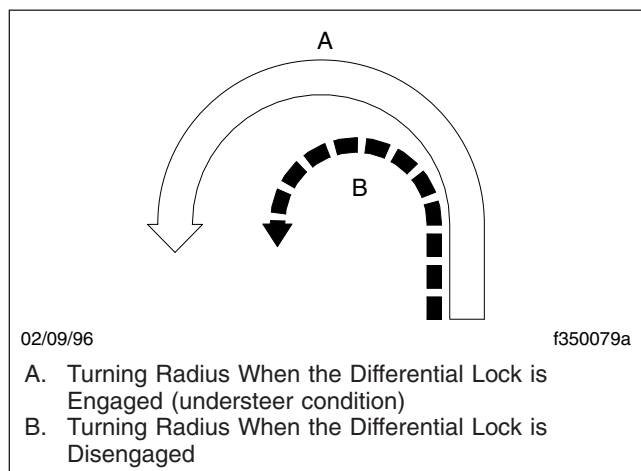

Fig. 16.3, Turning Radii

4. Press the lower half of the differential lock switch to disengage the differential lock after leaving poor road conditions.

NOTE: If the differential lock is engaged when the engine is shut down, the differential lock will disengage.

5. If the vehicle is moving, briefly let up on the accelerator to allow the wheels to fully unlock, then resume driving at normal speed.

Interaxle Lock

The interaxle lock (axle lock, interaxle differential lockout) feature is available on vehicles with tandem- or tridem-drive axles. The interaxle lock causes the drive axle shafts to rotate together, and is recommended for use under adverse road conditions where greater traction is needed.

See the axle manufacturer's website for more information.

When engaged, the interaxle lock essentially makes the driveshaft a solid connection between the drive axles. Power entering the forward drive axle is transmitted straight through to the rearmost axle(s). Driveline torque is now delivered equally and the drive axles, and wheels, turn together at the same speed. The interaxle lock increases drivetrain and tire wear and should be used only when improved traction is required.

Interaxle Lock Switch

The interaxle lock switch allows the driver to lock the drive axles together. See **Fig. 16.4**.

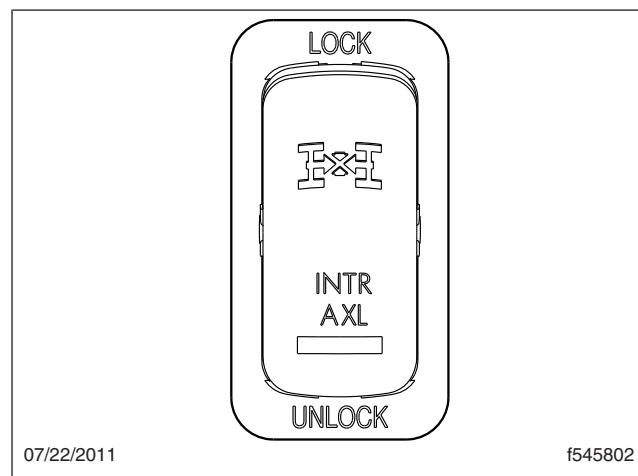

Fig. 16.4, Interaxle Lock Switch

Interaxle Lock Operation

NOTICE

The interaxle lock should not be engaged on a vehicle with obviously spinning wheels. Engagement at high speed or power can damage the axle(s).

1. With the engine running, press the upper half of the interaxle lock switch to engage the interaxle lock. Do not wait until traction is lost and the tires are spinning before engaging the interaxle lock.
2. If the vehicle is moving, briefly let up on the accelerator until the interaxle lock engages.

NOTICE

Do not operate the vehicle continuously with the interaxle locked during extended good road conditions. To do so could result in damage to the axle gearing and excessive driveline and tire wear.

3. Proceed over poor road conditions with caution.
4. Press the lower half of the interaxle lock switch to disengage the interaxle lock after leaving poor road conditions.

Drive Axles

NOTE: If the interaxle lock is engaged when the engine is turned off, the interaxle lock will disengage.

5. If the vehicle is moving, briefly let up on the accelerator to allow the interaxle lock to disengage, then resume driving at normal speed. Once the interaxle lock disengages, the indicator light will go off.

17

Fifth Wheels

Fifth Wheels, General Information	17.1
Fifth Wheel Coupling	17.1
Fifth Wheel Uncoupling	17.5
Fifth Wheel Slide	17.7

Fifth Wheels

Fifth Wheels, General Information

WARNING

Do not use any fifth wheel that fails to operate properly. Doing so may cause loss of vehicle control, possibly resulting in severe personal injury or death.

Air-Suspension Dump Valve

WARNING

Never exhaust air from the suspension while driving. The suspension will not absorb road shocks, possibly damaging components, and vehicle handling may be compromised. This could result in loss of vehicle control, possibly resulting in severe personal injury or death.

The air-suspension dump valve may be used to adjust the vehicle height in order to aid with coupling to or uncoupling from a trailer. See [Fig. 17.1](#). When the switch is set to DOWN, the air-suspension dump valve deflates the air springs to lower the rear of the vehicle. In the UP position, the automatic ride-control valves operate for normal driving.

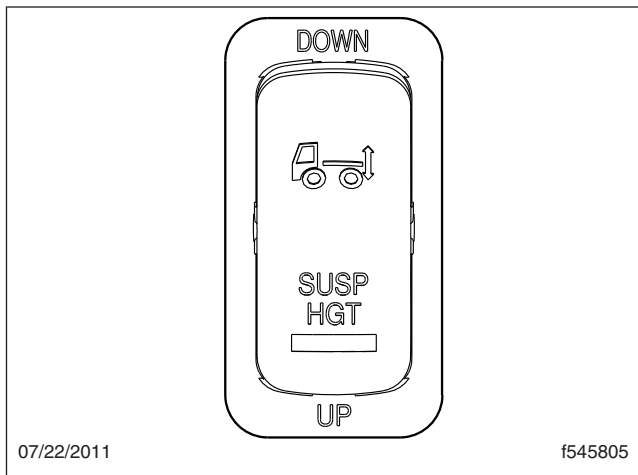

Fig. 17.1, Air-Suspension Dump Valve

NOTICE

Do not operate the vehicle over uneven ground such as ramps, speed bumps, curbs, etc. with the air springs deflated. Doing this may lead to air bag separation from the piston, preventing the suspension air springs from inflating.

Fifth Wheel Lubrication

WARNING

Keep the fifth wheel plate lubricated to prevent binding between the tractor and trailer. A binding fifth wheel could cause erratic steering and loss of vehicle control, possibly resulting in personal injury or death.

The standard fifth wheel plate must be kept well lubricated with chassis grease to prevent friction and binding between the vehicle fifth wheel plate and the trailer.

For a low-lube fifth wheel plate, inspect the condition of the low-lube pads. There should be no damaged or missing pieces. Slight puckering at the outside edges is normal.

For lubrication instructions, see **Group 31** of the *Western Star Maintenance Manual*.

Fifth Wheel Coupling

Fifth wheel coupling is activated with the lock control handle located on either the right or left side of the fifth wheel. Coupling is complete when the kingpin has been forced into the jaws and the lock control handle has moved to the locked position.

NOTICE

Some fifth wheels may be mounted on sliding rails. Before attempting to couple a trailer to a sliding fifth wheel, the slide feature must be locked to prevent the top plate from sliding rapidly forward or rearward, causing damage to the fifth wheel or kingpin.

Coupling, Fontaine and Holland Fifth Wheels

NOTE: For a tractor equipped with a Jost fifth wheel, see the heading **Coupling, Jost Fifth Wheel** below.

1. Chock the front and rear trailer tires.
2. Ensure the fifth wheel jaw is fully open and the operating rod is in the unlocked position. See [Fig. 17.2](#) or [Fig. 17.3](#).

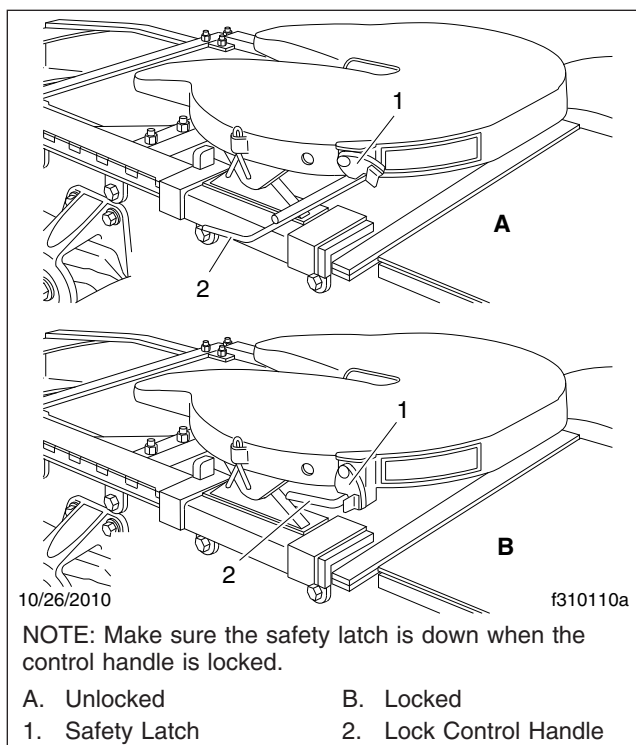

Fig. 17.2, Fontaine Locking Mechanism

3. Make sure the fifth wheel top plate is tilted so the ramps are as low as possible.
4. Position the tractor so that the center of the fifth wheel is in line with the trailer kingpin. The kingpin should be in a position to enter the throat of the locking mechanism.

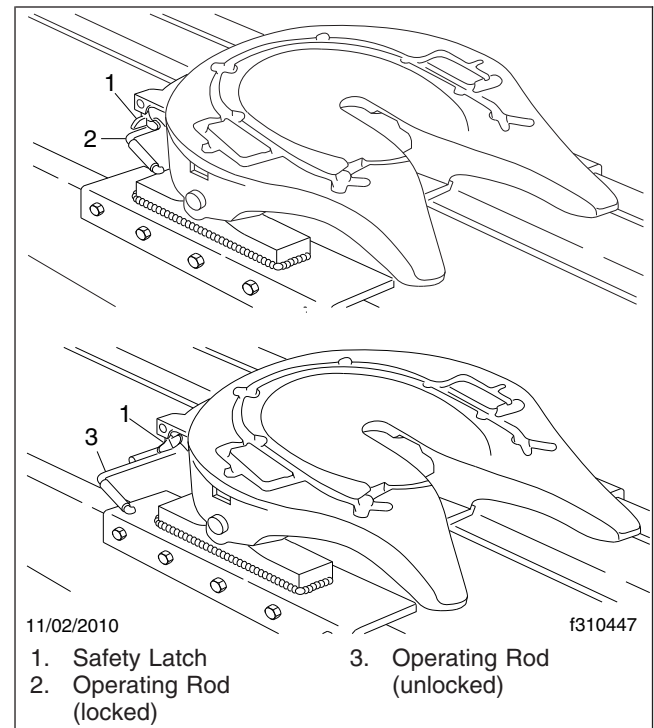

Fig. 17.3, Holland Simplex SE Locking Mechanism

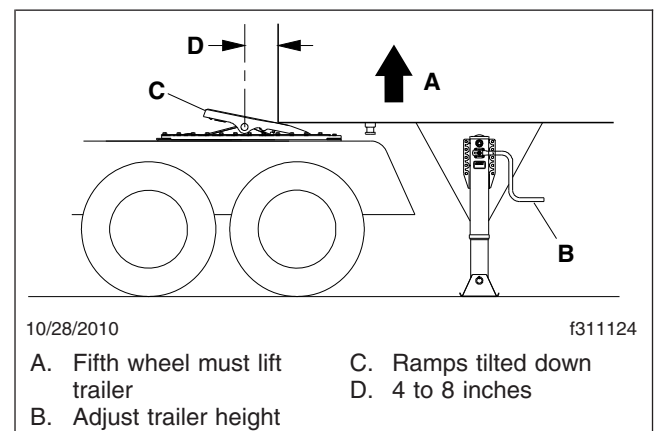

Fig. 17.4, Trailer Connection Point, Standard Fifth Wheel Plate

NOTICE

Attempting to couple at the wrong height may cause improper coupling, which could result in damage to the fifth wheel or kingpin.

5. Adjust the trailer height if required.

Fifth Wheels

For a **standard fifth wheel plate**, the trailer should contact the fifth wheel approximately 4 to 8 inches (10 to 20 cm) behind the fifth wheel pivot. See [Fig. 17.4](#).

For a **low-lube fifth wheel plate**, the fifth wheel must slide freely under the trailer, and the trailer should contact the fifth wheel at the pivot. See [Fig. 17.5](#).

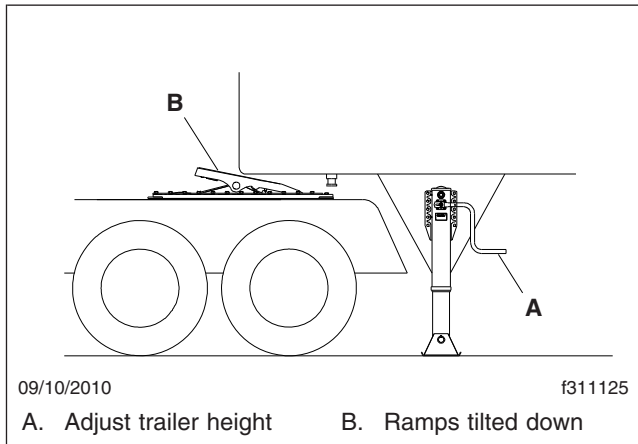

Fig. 17.5, Trailer Connection Point, Low-Lube Fifth Wheel Plate

6. With the fifth wheel lock opening aligned with the trailer kingpin, back the tractor slowly toward the trailer. After sliding under the trailer, stop to avoid hitting the kingpin too hard, then resume backing slowly until the fifth wheel locks.

For a **standard fifth wheel plate**, the fifth wheel must lift the trailer.

For a **low-lube fifth wheel plate**, do not lift the trailer as this may damage the fifth wheel plate.

7. Set the tractor parking brake.

WARNING

A visual inspection is required by law. Some improper couplings can pass a pull test. Sound is not reliable. Get out of the cab and look. Incorrect coupling could cause the trailer to disconnect, possibly resulting in serious personal injury or death.

8. Perform a coupling inspection, checking that there is no gap between the bottom of the trailer and the fifth wheel, and that the kingpin is securely locked. See [Fig. 17.6](#).

When lockup has occurred, the fifth wheel control handle moves to the locked position. Make sure that the safety latch is down over the lock control handle to hold the control handle in the locked position (the safety latch will only rotate down if the operating rod is fully retracted in the locked position). See [Fig. 17.2](#) or [Fig. 17.3](#).

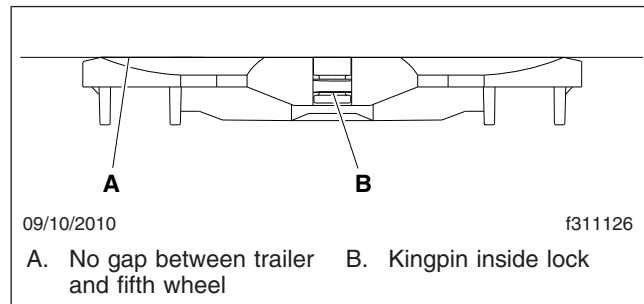

Fig. 17.6, Coupling Inspection

9. Release the tractor parking brake. Test for kingpin lockup by slowly inching the tractor forward, pulling on the trailer against the chocks.
10. After lockup is completed, connect the tractor-to-trailer air system lines and the electrical cable to the trailer. Take care to prevent dirt or foreign material from entering the air system lines.

NOTICE

Always make sure the connection hanger keeps the trailer air hoses and electrical cables positioned so that they do not rub on anything. Rubbing may wear through hoses or cables, resulting in air leaks, or exposed or broken wires, potentially affecting trailer brake or electrical systems.

11. Charge the air brake system and check that the air connections do not leak.

WARNING

Incorrect fifth wheel lock adjustment could cause the trailer to disconnect, possibly resulting in serious personal injury or death.

12. With the trailer tires chocked and the brakes set, check for clearance between the kingpin and the fifth wheel jaws by moving the tractor forward and backward against the locked kingpin. If slack is present, uncouple the trailer and have the fifth

wheel inspected and adjusted by a certified technician.

Coupling, Jost Fifth Wheel

NOTE: For a tractor equipped with a Fontaine or Holland fifth wheel, see the heading **Coupling, Fontaine and Holland Fifth Wheels** above.

1. Tilt the ramp down.
2. Open the kingpin locks. See [Fig. 17.7](#).

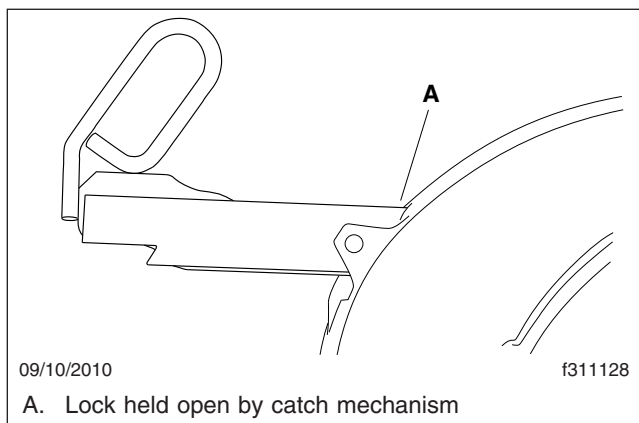

Fig. 17.7, Jost Release Handle Unlocked

3. Back the tractor close to the trailer, centering the kingpin on the fifth wheel.
4. Chock the trailer tires.
5. Connect the air lines and electrical cable.
6. Ensure that the trailer air supply valve (trailer brake) is pulled out, and that the trailer parking brakes are set. See [Fig. 17.8](#).

NOTICE

Attempting to couple at the wrong height may cause improper coupling, which could result in damage to the fifth wheel or kingpin.

7. Adjust the trailer height (if required).

For a standard fifth wheel plate, the trailer should contact the fifth wheel approximately 4 to 8 inches (10 to 20 cm) behind the pivot. See [Fig. 17.4](#).

For a low-lube fifth wheel plate, the fifth wheel must slide freely under the trailer, and the trailer should contact the fifth wheel at the pivot. See [Fig. 17.5](#).

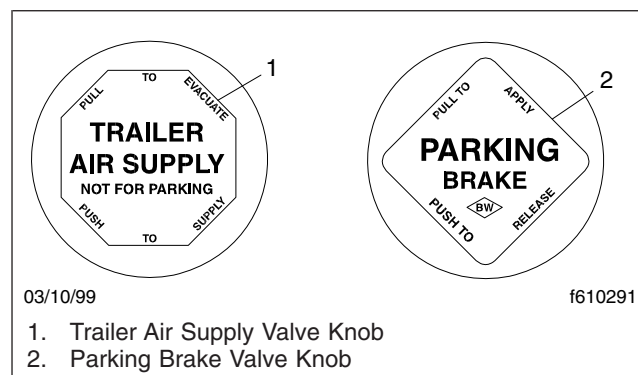

Fig. 17.8, Brake Valve Knobs

8. Back the tractor under the trailer.

For a standard fifth wheel plate, the fifth wheel must lift the trailer.

For a low-lube fifth wheel plate, do not lift the trailer as this may damage the fifth wheel plate.
9. After sliding under the trailer, stop to avoid hitting the kingpin too hard, then resume backing slowly until the fifth wheel locks.
10. Set the tractor parking brake.

WARNING

A visual inspection is required by law. Some improper couplings can pass a pull test. Sound is not reliable. Get out of the cab and look. Incorrect coupling could cause the trailer to disconnect, possibly resulting in serious personal injury or death.

11. Perform a physical check for positive kingpin lockup, ensuring that there is no gap between the trailer and the fifth wheel. See [Fig. 17.6](#).
12. Ensure that the release handle is in the locked position adjacent to the casting. See [Fig. 17.9](#).
13. Release the tractor parking brake and test for kingpin lockup by slowly moving the tractor forward, pulling on the trailer against the chocks.

Fifth Wheels

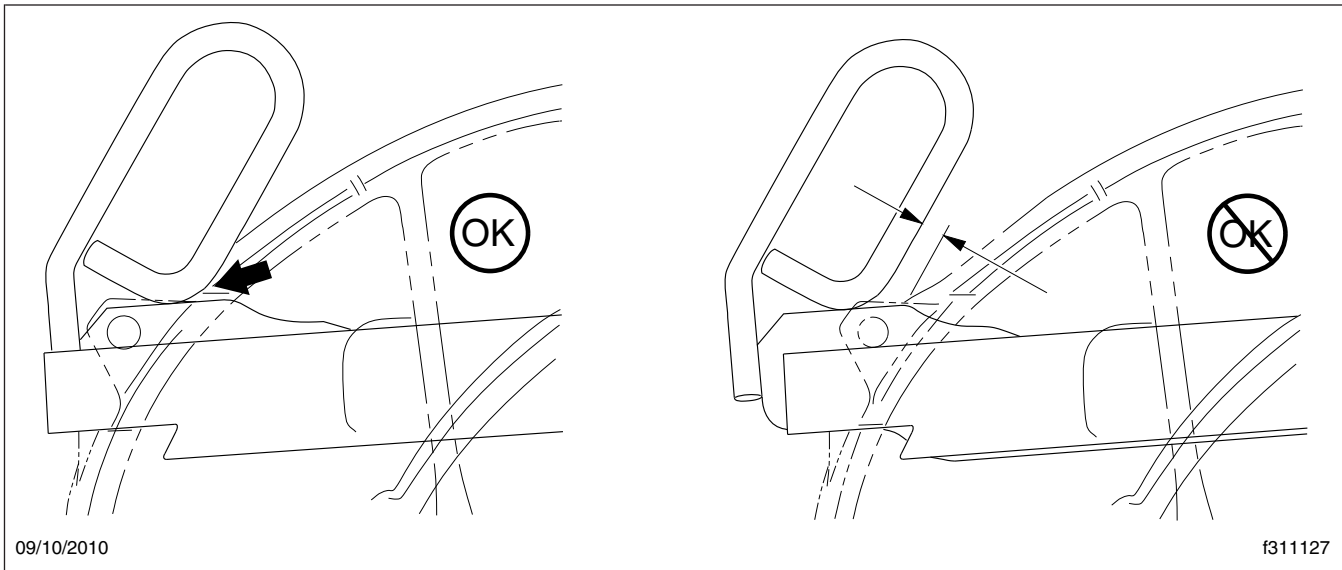

Fig. 17.9, Jost Release Handle Locked

Fifth Wheel Uncoupling

Manual Uncoupling

1. Set the tractor and trailer parking brakes.
2. Chock the trailer rear wheels.
3. Lower the trailer landing gear until the weight is removed from the fifth wheel.
4. Disconnect the tractor-to-trailer air system lines and electrical cable. Plug the air lines to prevent dirt or foreign material from entering the lines.
5. Verify that both the parking brake and trailer air supply knobs are out (see Fig. 17.8), the tractor and trailer parking brakes are set, and that the trailer is prepared for uncoupling.
6. Release the kingpin locking mechanism following the instructions for each manufacturer listed below.
 - 6.1 **Fontaine:** Lift the safety latch and pull the lock control handle to the unlocked position. See Fig. 17.2.
 - 6.2 **Holland:** In the locked position the safety indicator swings freely over the operating rod. See Fig. 17.10, View A.

To unlock the mechanism, manually rotate the safety indicator toward the rear of the fifth wheel. See Fig. 17.10, View B.

Pull the operating rod out. When the upper operating rod shoulder is outside the slot, raise the handle and place the shoulder of the upper rod against the plate casting, above the slot. See Fig. 17.10, View C.

The fifth wheel is now in the lock position and is ready for uncoupling. As the tractor pulls away from the trailer the kingpin forces the jaw to rotate, contacting the lock. Continued rotation of the jaw forces the lock to move outward, and drops the upper rod back into the slot. See Fig. 17.10, View D. The wheel is now ready for coupling.

- 6.3 **Jost:** Pull the retractable handle out, then secure it in the open position with the catch. See Fig. 17.7.
7. Release the tractor parking brake, then drive forward slowly, allowing the trailer to slide down the fifth wheel and pick-up ramps.

Air-Actuated Uncoupling

An air-actuated kingpin release valve is optional with all fifth wheels. See Fig. 17.11.

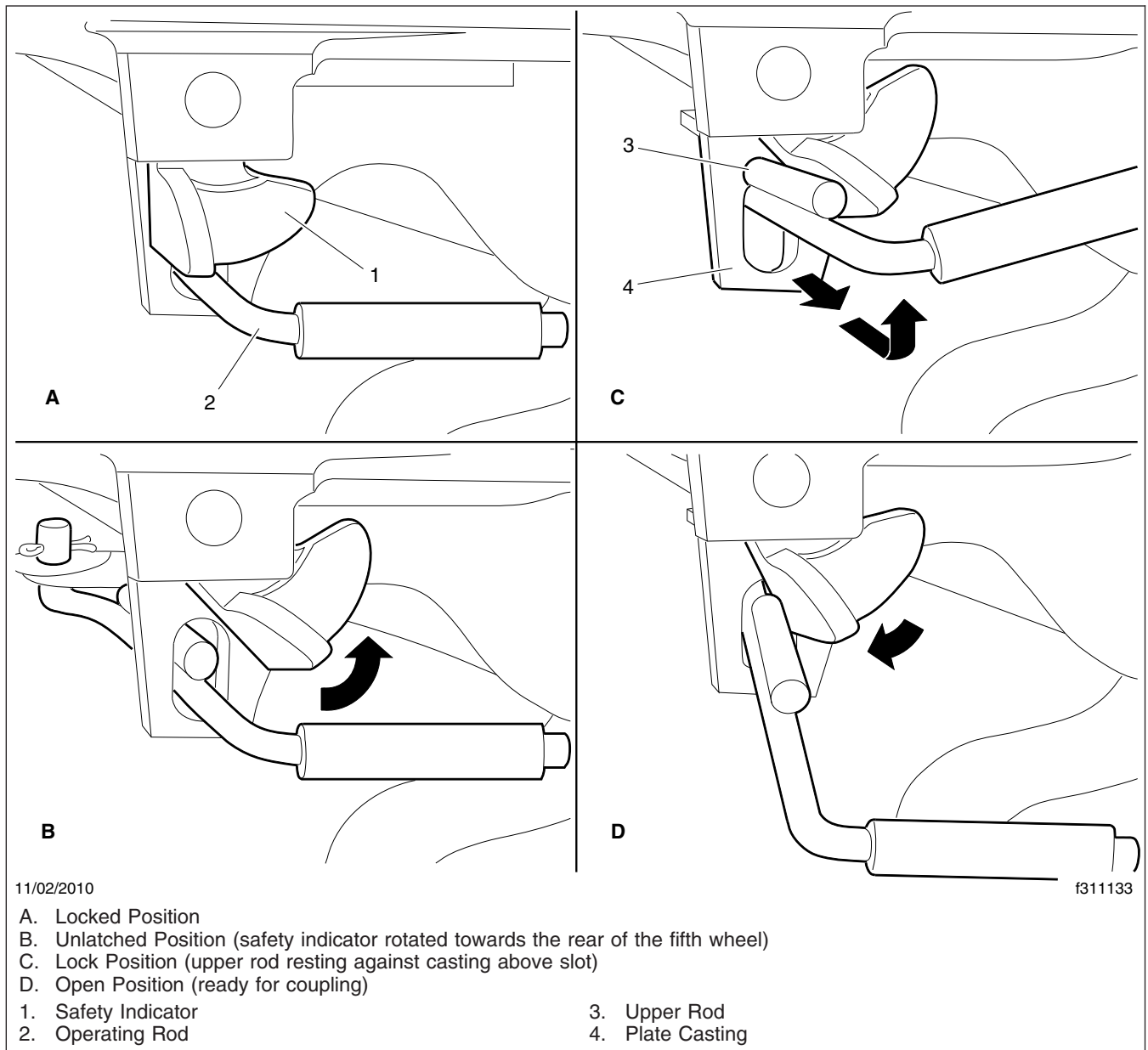

Fig. 17.10, Holland Kingpin Locking Mechanism

NOTE: In the event of an air system failure, air-actuated kingpins can be manually released following the instructions for manual unlocking.

⚠ WARNING

Once the kingpin release valve has been pulled the kingpin lock is released. The vehicle **MUST NOT** be driven with the trailer until the trailer has been uncoupled and coupled again. Failure to do so may result in separation of the trailer from the

Fifth Wheels

tractor, possibly causing serious personal injury or death.

Preparing the Trailer for Uncoupling

Before using the air valve to unlock a fifth wheel kingpin, prepare the trailer as follows.

1. Set the tractor and trailer parking brakes.
2. Chock the rear trailer tires.
3. Lower the trailer landing gear until the weight is removed from the fifth wheel.
4. Disconnect the tractor-to-trailer air lines and electrical cable. Plug the air lines to prevent dirt or foreign material from entering the lines.

Air-Activated Kingpin Unlock, Fontaine and Holland Fifth Wheels

1. Verify that both the parking brake and trailer-air supply knobs are out (see Fig. 17.8), the tractor and trailer parking brakes are set, and that the trailer is prepared for uncoupling.

NOTE: If the tractor parking brake is not set, the air-actuated kingpin-release valve will not activate.

2. Pull and hold the kingpin release valve (Fig. 17.11) until the kingpin lock mechanism opens and locks in place.

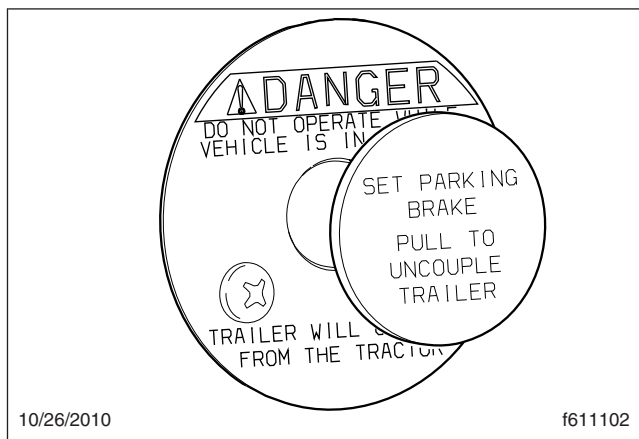

Fig. 17.11, Air-Actuated Kingpin Release Valve

3. Let go of the kingpin release valve.
4. Release the tractor parking brake.

5. Drive out from under the trailer.

Air-Activated Kingpin Unlock, Jost Fifth Wheels

1. Verify that both the parking brake and trailer air supply knobs are out (see Fig. 17.8), the tractor and trailer parking brakes are set, and that the trailer is prepared for uncoupling.

NOTE: If the trailer parking brake is not set, the air-actuated valve will not activate.

2. Release the tractor parking brake.
3. Pull and hold the kingpin release valve, then drive forward slowly.
4. After the trailer has slid down the fifth wheel and pick-up ramps, let go of the kingpin release valve.

Fifth Wheel Slide

WARNING

Adjust the fifth wheel slide correctly, and do not overload any tractor axle by incorrectly loading the trailer. Incorrect slide adjustment or improper axle loading could cause erratic steering and loss of vehicle control, possibly resulting in serious personal injury or death.

On sliding fifth wheel assemblies, the fifth wheel plate is attached to rails that allow forward and rearward movement of the fifth wheel in order to optimally distribute the load across the axles. Slots are evenly spaced along the slide rails, and retractable wedges are positioned through the slots to hold the fifth wheel in the desposition.

The amount of load distribution on the front steering axle and rear drive axle(s) will have a direct effect on the steering control of the tractor. Determine the front and rear axle weights by weighing the tractor on scales designed for this purpose.

The maximum axle weight ratings are shown on the Federal Motor Vehicle Safety Standard (FMVSS) label or Canadian Motor Vehicle Safety Standard (CMVSS) label attached to the driver-side door frame. The desired load on the axle is no less than 80 percent of the maximum axle weight rating, but in

no instances should the axle load exceed the maximum axle weight rating given on the FMVSS or CMVSS label.

Manual Slide Operation

Use the following procedure to manually slide the fifth wheel. See [Fig. 17.12](#).

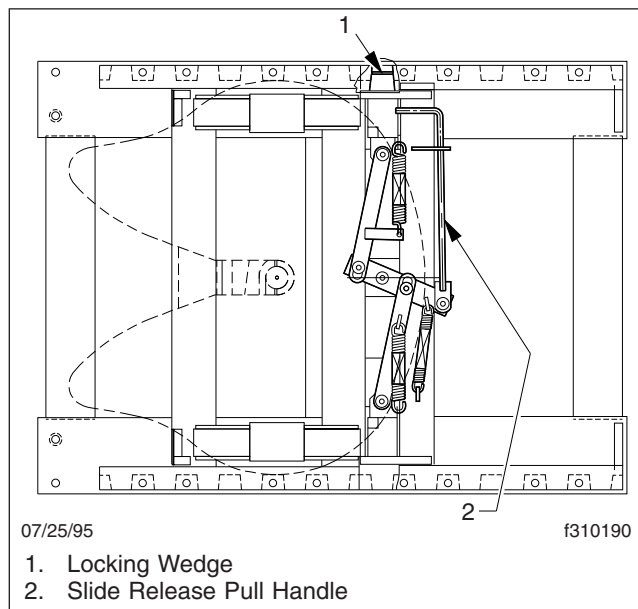

Fig. 17.12, Manual Release Sliding Fifth Wheel, Fontaine

1. Stop the tractor and trailer in a straight line on level ground. Pull the trailer air supply knob to set the trailer parking brakes.
2. Set the tractor parking brake, then release the sliding mechanism using the appropriate method for the fifth wheel manufacturer.
 - 2.1 **Fontaine:** Lift the slide release pull handle to disengage it from the guide plate. Then, pull out the handle until it is in the unlocked position and can be positioned against the guide plate to hold it out. The handle will stay in the unlocked position until it is manually disengaged from the guide plate. See [Fig. 17.13](#).
 - 2.2 **Holland:** Pull the operating rod out. Make sure both side plungers have released. See [Fig. 17.14](#).

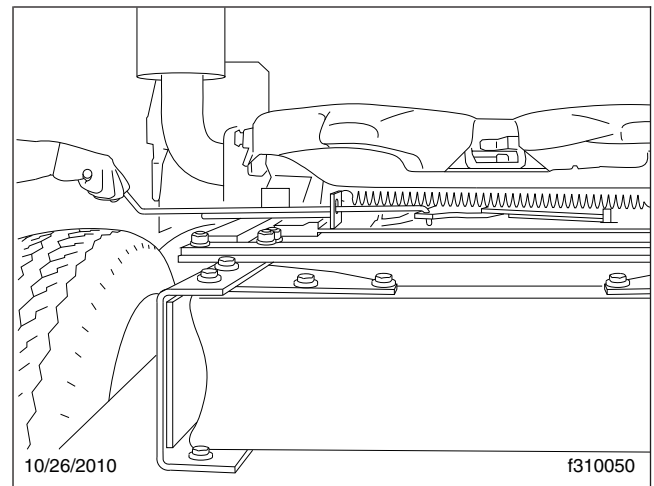

Fig. 17.13, Sliding Fifth Wheel Manual Release, Fontaine

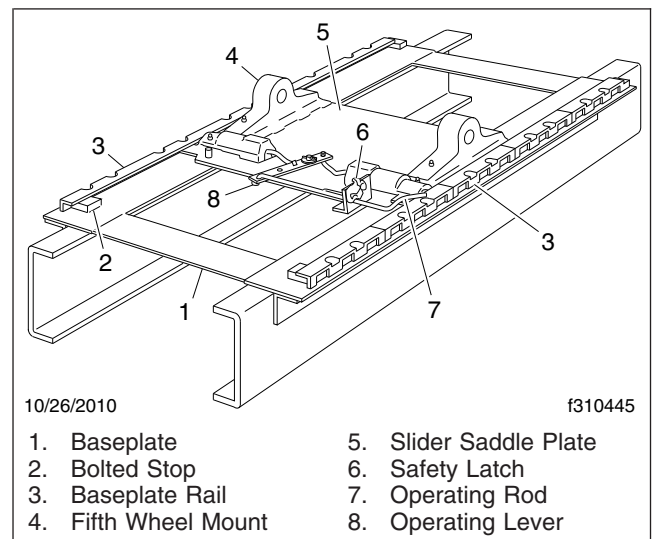

Fig. 17.14, Sliding Fifth Wheel Manual Release, Holland Simplex

3. Lower the trailer landing gear just enough to remove the weight from the tractor.
4. Chock the front and rear trailer tires to prevent the trailer from moving.

NOTICE

When moving the fifth wheel to the desposition, be sure the trailer landing gear will not at any time come in contact with the tractor frame or

Fifth Wheels

other components. Make sure that the front of the trailer will not come in contact with the rear of the cab or with other components if they extend beyond the rear of the cab.

5. Release the tractor parking brake, then slowly move the tractor forward or backward until the fifth wheel is in the desilocation.

WARNING

Check that the locking wedges have seated in the slots. Failure to achieve complete lockup may allow disengagement of the tractor from the trailer, possibly resulting in serious personal injury or death.

6. Set the tractor parking brake, then lock the sliding member in position using one of the following methods:
 - 6.1 **Fontaine:** Disengage the slide release pull handle from the guide plate. The slide release pull handle is spring-loaded in the locked position and will seek the locked position when disengaged from the guide plate. After the slide release pull handle returns to the fully locked position, visually and physically check the locking wedges to make sure they are fully inserted into the slots in the slide rails. Make sure the handle is locked in position against the guide plate.
 - 6.2 **Holland:** Raise the operating rod so that it is free to move inward. Make sure that the lock pins have seated in the base plate rail holes and the operating rod moves into the locked position.

NOTE: The fifth wheel may need to be moved slightly to enable the locking wedges to enter the fully locked position.

Air Slide Operation

The slide feature may be operated with a dash-mounted switch that operates an air cylinder that locks and unlocks the slide.

1. Press the top half of the air-slide switch to enable the air-slide feature. See [Fig. 17.15](#)

Ensure the locking plungers have released. See [Fig. 17.16](#).

For Jost fifth wheels, the mechanism activates as shown in [Fig. 17.17](#).

2. Lower the trailer landing gear just enough to remove the weight from the tractor.
3. Pull the trailer air supply knob to set the trailer parking brakes.
4. Slowly move the tractor forward or backward until the fifth wheel is in the desilocation.

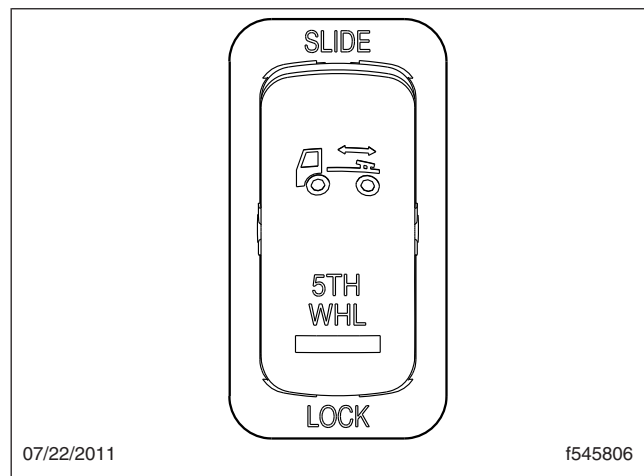

Fig. 17.15, Fifth Wheel Slide Switch

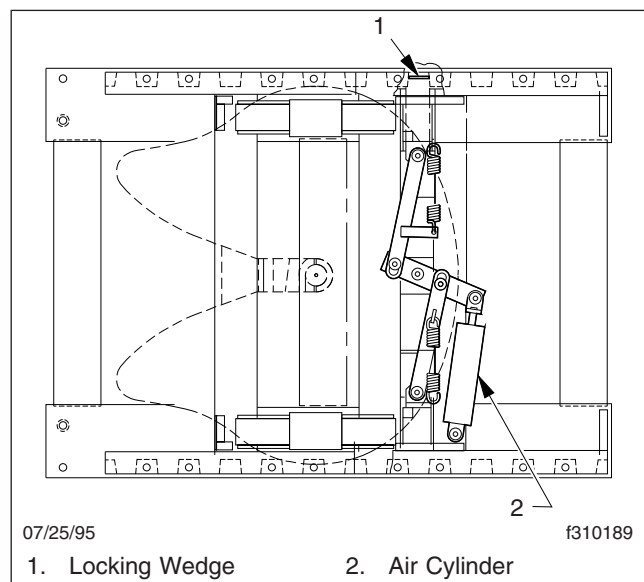

Fig. 17.16, Air-Operated Sliding Fifth Wheel, Fontaine

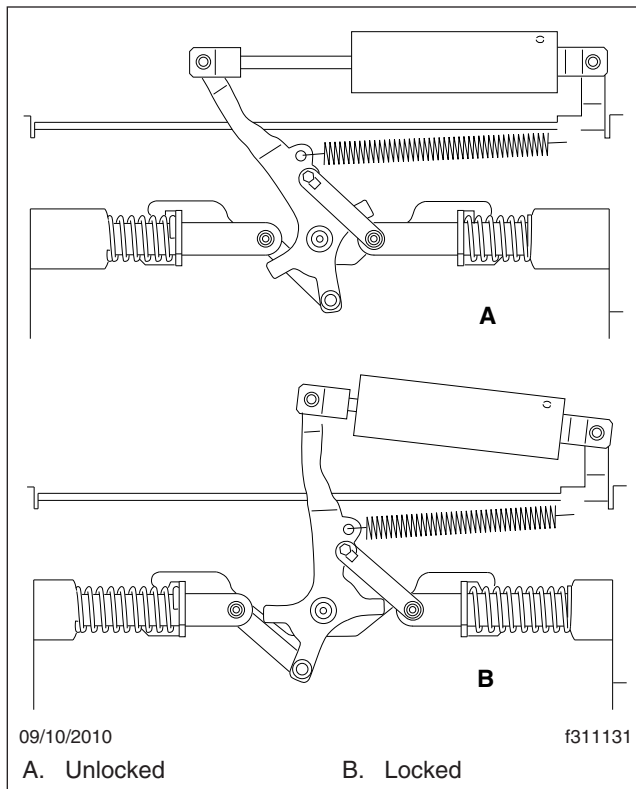

Fig. 17.17, Jost Sliding Fifth Wheel

that the plungers have engaged by tugging the tractor forward while the trailer brakes are locked and the tires are chocked.

NOTE: The fifth wheel may need to be moved slightly to enable the locking wedges to fully lock.

NOTICE

Ensure the trailer landing gear does not come in contact with the tractor frame or other components, and that the front of the trailer will not come in contact with the rear of the cab or other components if they extend beyond the rear of the cab.

5. Set the tractor parking brake.

WARNING

Check that the locking wedges have seated in the slots. Failure to achieve complete lockup may allow disengagement of the tractor from the trailer, possibly resulting in serious personal injury or death.

6. Press the lower half of the air-slide switch to disable the air-slide feature. Visually inspect the locking wedges or plungers to make sure that they are fully inserted in the slide rail slots. Verify

18

Trailer Couplings

Air-Suspension Dump Valve	18.1
Premier Trailer Couplings	18.1

Trailer Couplings

Air-Suspension Dump Valve

WARNING

Never exhaust air from the suspension while driving. The suspension will not absorb road shocks, possibly damaging components, and vehicle handling may be compromised. This could result in loss of vehicle control, possibly resulting in severe personal injury or death.

The air-suspension dump valve may be used to adjust the vehicle height in order to aid with coupling to or uncoupling from a trailer. See [Fig. 18.1](#). When the switch is set to DOWN, the air-suspension dump valve deflates the air springs to lower the rear of the vehicle. In the UP position, the automatic ride-control valves operate for normal driving.

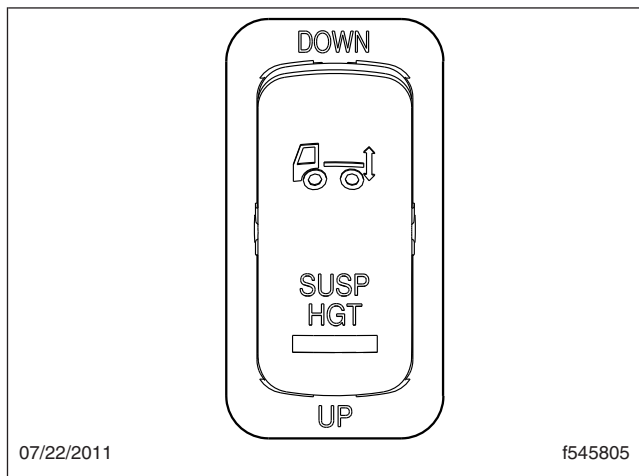

Fig. 18.1, Air-Suspension Dump Valve

NOTICE

Do not operate the vehicle over uneven ground such as ramps, speed bumps, curbs, etc. with the air springs deflated. Doing this may lead to air bag separation from the piston, preventing the suspension air springs from inflating.

Premier Trailer Couplings

General Information

IMPORTANT: Before operating the Premier coupling, refer to the Premier website

(www.premier-mfg.com) for complete safety, operation, and maintenance instructions.

Trailer couplings are attached to the rear closing crossmember. The Premier trailer couplings ([Fig. 18.2](#)) are designed for use with trailers having a maximum gross weight of 100,000 lbs (45 455 kg).

The Premier 2200 and 2400 trailer couplings are air-adjusted couplings with a rigid pintle hook. An air chamber mounted forward of the coupling operates a push rod, which pushes against a shoe inside the coupling. The shoe maintains constant pressure on the eye of the trailer drawbar when it's over the pintle hook. This takes up any slack in the trailer connection, providing smoother towing and less wear on the pintle hook. The air pressure is activated when the trailer brakes are released.

Trailer Hookup

1. Chock the front and rear tires of the trailer.
2. Push the latch lock towards the mounting plate as far as possible. Then, while holding the latch lock in place against the mounting plate, pull the top of the latch as far as possible toward the pintle hook.
3. While holding the latch in place, release the latch lock.
4. Back the vehicle up until the drawbar eye is over the pintle hook, then lower the trailer.
5. Pull the top of the latch as far as possible toward the pintle hook. Then, while holding the latch in position, push the latch lock towards the mounting plate.
6. While holding the latch lock in place against the mounting plate, release the latch.
7. Release the latch lock and make sure it is fully seated in the slot on top of the latch.

NOTICE

Always make sure the connection hanger keeps the trailer air hoses and electrical cables positioned so that they do not rub on anything. Rubbing may wear through hoses or cables, resulting in air leaks, or exposed or broken wires, potentially affecting trailer brake or electrical systems.

8. Connect the trailer's electrical and air lines.

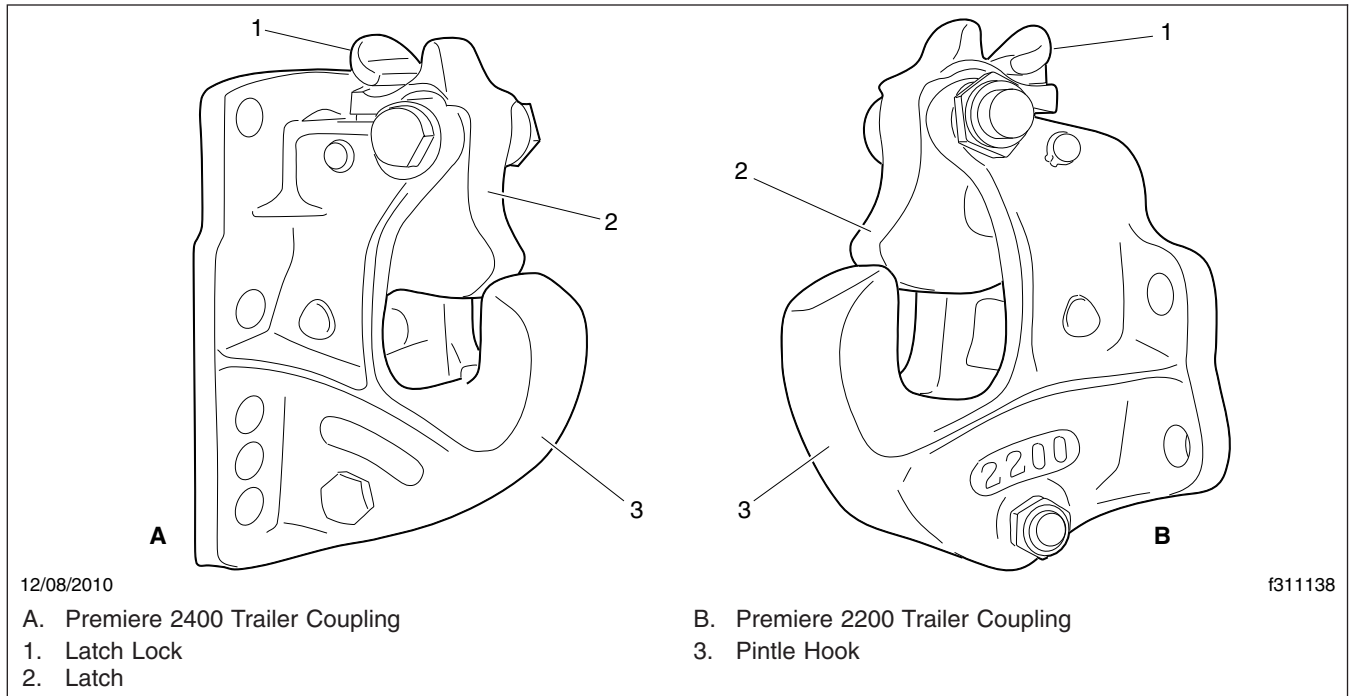

Fig. 18.2, Premiere 2200 and 2400 Trailer Couplings

Trailer Release

1. Set the vehicle and trailer parking brakes.

WARNING

If a trailer or combination vehicle is not equipped with spring parking brakes, do not park it by pulling out only the trailer air supply valve knob. This would apply only the trailer service brakes. If air were to bleed from the trailer brake system, the trailer brakes would release, possibly causing an unattended runaway vehicle.

2. Chock the front and rear tires of the trailer.
3. Disconnect the trailer air and electrical lines. Plug the air lines to keep them free of dirt.
4. Take the weight of the trailer drawbar eye off the pintle hook.
5. Push the latch lock towards the mounting plate as far as possible. Then, while holding the latch lock in this position, pull the top of the latch as far as possible toward the pintle hook.

6. While holding the latch in place, release the latch lock.
7. Slowly drive the vehicle away from the trailer.

19

Headlight Aiming

Preliminary Checks	19.1
Checking Headlight Aim	19.1
Adjusting Headlight Aim	19.1

Headlight Aiming

Preliminary Checks

Before checking or adjusting the headlight aim, complete the following inspection:

- Check that the hood is closed and latched.
- Remove any large amounts of mud or ice from the underside of the fenders.
- Check the springs for sagging or broken leaves.
- Check the suspension for proper functioning of the leveling mechanism. On cabs with air suspensions, make sure that the height is properly adjusted.
- Check for damage to the hood and hinge assembly. Repair as necessary.
- With the vehicle unloaded, check that the tires are inflated to the recommended air pressure.
- Clean the headlight lenses. Use a soft cloth with mild, non-caustic soap or detergent, and water.

Checking Headlight Aim

1. Park the vehicle on a level surface, 25 ft (7.6 m) away from, and perpendicular to, a vertical screen or wall. Shut down the engine and set the parking brake. Chock the tires.
2. On each headlight, find the bulb center behind the headlight lens.
3. Measure the distance from the ground to the center of each headlight bulb (**Fig. 19.1**, Item A). Note those distances.
4. On the screen or wall, mark the locations of each headlight bulb center using the distances found in step 3. See **Fig. 19.1**, Items 2 and 3.
5. Turn on the low-beam headlights.

NOTE: See the following heading, **Adjusting Headlight Aim**, for adjustment instructions.

6. Check the horizontal aim of the low beams. The center of each beam projection should fall on or near the marks made during step 4 (**Fig. 19.1**, Items 2 and 3).

If the center of any projection is more than 3.9 in (100 mm) to the side of the marks made in step 4, adjust the horizontal aim of that headlight.

7. Check the vertical adjustment of the low beams. The center of each beam projection should fall on or near the marks made during step 4. See **Fig. 19.2**.
8. Use **Table 19.1** to determine the maximum vertical distance allowable between the marks on the wall and the center of each low-beam projection. If the distance between either projection center and the mark made on the wall or screen is greater than the maximum distance given in **Table 19.1**, adjust the vertical positioning of that headlight.
9. Turn on the high-beam headlights. Ensure the beam projections are parallel to the ground. If the beam projections are not parallel to the ground, adjust the positioning of the high-beam bulbs.

Adjusting Headlight Aim

NOTE: Western Star vehicles are offered with various headlight assembly options. Because of the various options, the location of adjustment screws on your vehicle's headlight assembly may vary from what is shown here.

For adjustment screw locations on a vehicle with dual rectangular headlight assemblies, see **Fig. 19.3**. For adjustment screw locations on a vehicle with dual round headlight assemblies, see **Fig. 19.4**. For adjustment screw locations on a 4700 model, see **Fig. 19.5**.

Turn the adjustment screw in either direction until the beam pattern meets the acceptable standard.

Headlight Aiming

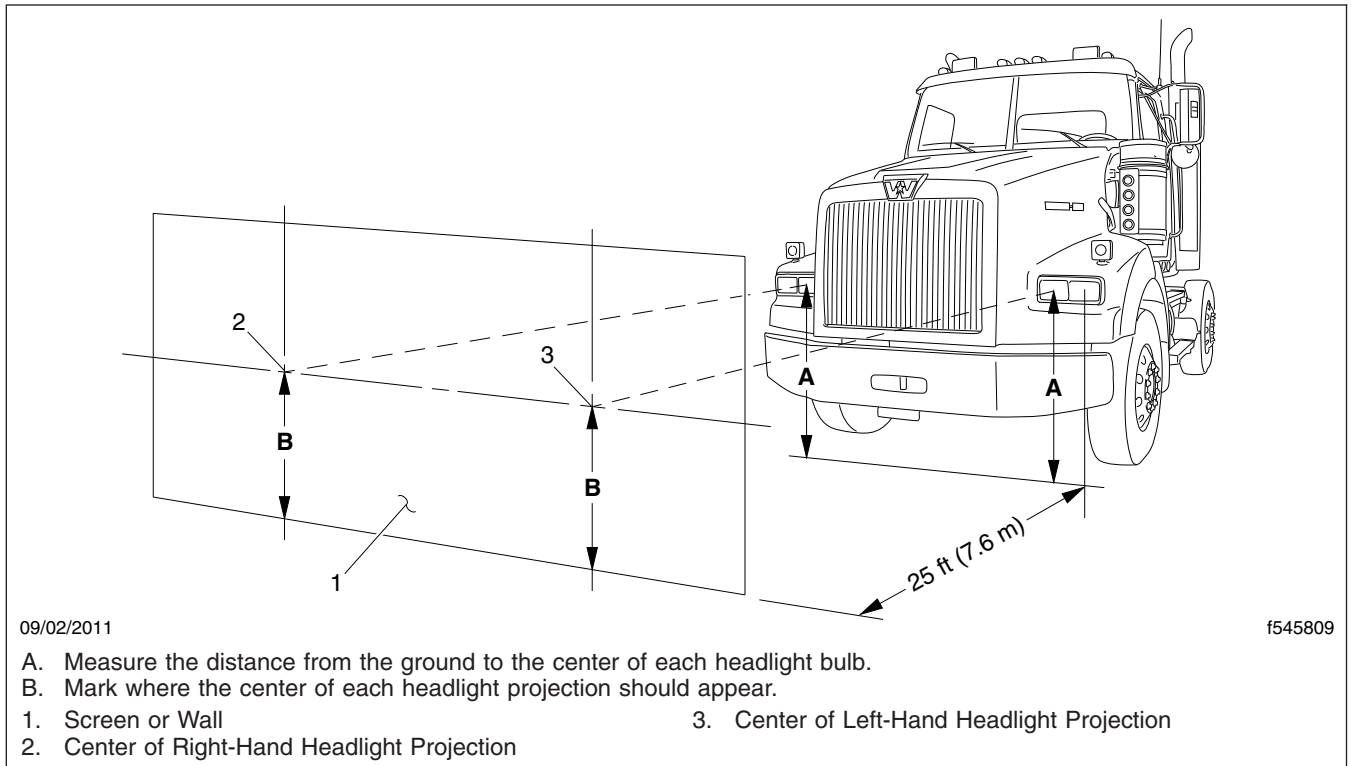

Fig. 19.1, Headlight Aiming Screen/Wall

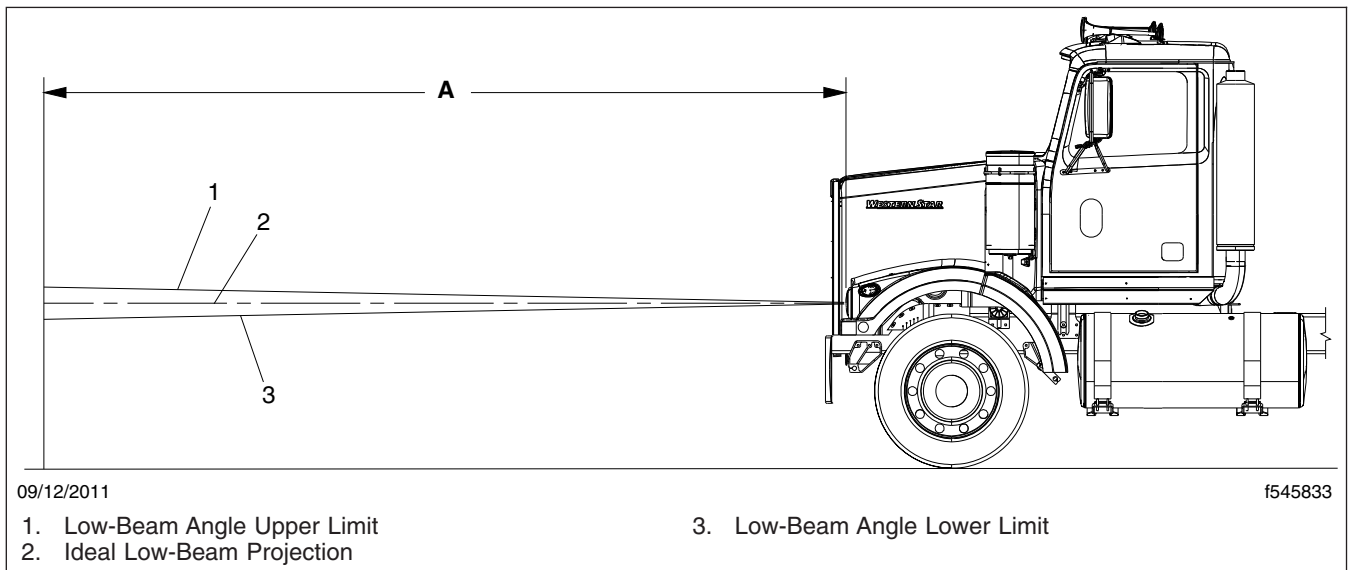

Fig. 19.2, Vertical Low-Beam Headlight Variation Limits

Headlight Aiming

Vertical Low-Beam Headlight Variation Limits			
Distance Between Ground and Headlight: in (mm)	Desired Variation (Fig. 19.2, Item 2) : in (mm)	Upper Limit (Fig. 19.2, Item 1): in (mm) up	Lower Limit (Fig. 19.2, Item 3): in (mm) down
22–36 (560–900)	0	3.9 (100)	3.9 (100)
36–48 (900–1200)	2 (50) down	2 (50)	6 (150)
48–54 (1200–1400)	2.5 (64) down	1.6 (40)	6.5 (165)

Table 19.1, Vertical Low-Beam Headlight Variation Limits

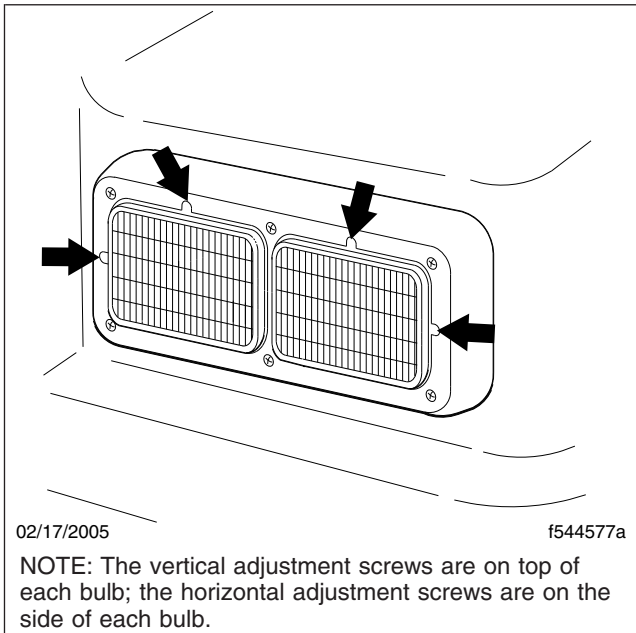

Fig. 19.3, Adjustment Screw Locations, Dual Rectangular Headlights

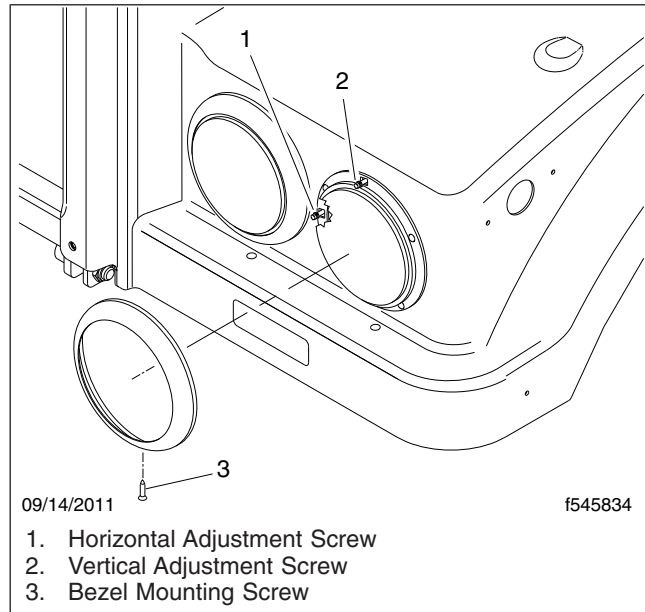

Fig. 19.4, Adjustment Screw Locations, Dual Round Headlights

Headlight Aiming

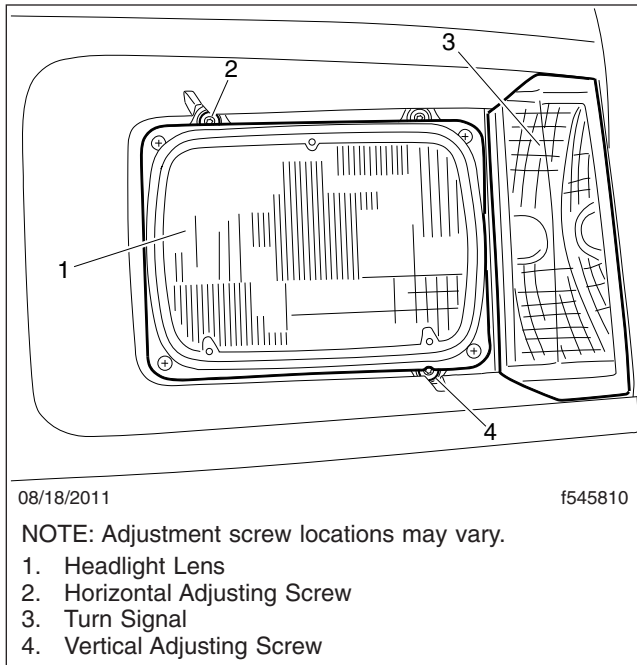

Fig. 19.5, Single Headlight Assembly (4700 model shown)

20

Vehicle Appearance and Care

Cab Washing and Polishing	20.1
Care of Chrome Parts	20.1
Dashboard Care	20.1
Vinyl Upholstery Cleaning	20.2
Velour Upholstery Cleaning	20.2
Star Gauge Face Care	20.3
Care of Exterior Lights	20.3

Vehicle Appearance and Care

Cab Washing and Polishing

IMPORTANT: Carefully read all instructions before using or applying any cleaner or product to the vehicle or components. Failure to follow manufacturers' recommendations can result in damage to the finish.

To protect the finish of a new vehicle, follow these guidelines carefully:

- During the first 30 days, rinse the vehicle frequently with water. If the vehicle is dirty, use a mild liquid soap. Do not use detergent.
- During the first 30 days, do not use anything abrasive on the vehicle. Brushes, chemicals, and cleaners may scratch the finish.
- During the first 120 days, do not wax the vehicle.

To extend the life of the vehicle's finish, follow these guidelines:

- Avoid washing the vehicle in the hot sun.
- Always wash the vehicle with water. After the cab is completely washed, dry it with a towel or chamois.
- Do not dust painted surfaces with a dry cloth, as this will scratch the paint.
- Do not remove ice or snow from a painted surface with a scraper of any sort.
- To prevent damage to the finish, wax it regularly. Before waxing, if the finish has become dull, remove oxidized paint using a cleaner specifically designed for this purpose. Remove all road tar and tree sap before waxing. Western Star Trucks recommends using a high quality brand of cleaner or cleaner-polish and polishing wax.
- Do not let diesel fuel or antifreeze stand on a painted surface. If either should occur, rinse the surface off with water.
- To prevent rust, have any nicks or other damage on the finish touched up as soon as possible.
- Park the vehicle in a sheltered area whenever possible.

To prevent delamination and deterioration of labels and stickers on the cab, follow these guidelines carefully:

- Do not pressure wash the label or sticker or surfaces near it.
- Do not use strong alkaline soaps on or near the label or sticker.

Care of Fiberglass Parts

Wash unpainted fiberglass air fairings and shields monthly with a mild detergent, such as dishwashing liquid. Avoid strong alkaline cleansers.

Apply a wax specifically designed for fiberglass.

Care of Chrome Parts

To prevent rust, keep chrome parts clean and protected at all times. This is especially important during winter driving and in coastal areas where there is exposure to salt air.

When cleaning chrome, use clean water and a soft cloth or sponge. A mild detergent may also be used.

Sponge gently, then rinse. If necessary, use a non-abrasive chrome cleaner to remove stubborn rust or other material. Do not use steel wool.

To help protect chrome after cleaning, apply a coat of polishing wax to the surface. Never use wax on components that are exposed to high heat, such as exhaust pipes.

Dashboard Care

NOTICE

When cleaning the dashboard, instrument panel, or gauge lens covers, do not use Armor-All Protectant®, STP Son-of-a-Gun®, window cleaner, or other equivalent treatments. These cleaners contain vinyl plasticizers which can cause stress crazing in the interior plastic panels and can result in cracking of the panels. Some cleaners can also have an adverse effect on the clear plastic of instrument panels and gauge lens covers, resulting in a foggy or cloudy appearance. This type of damage is not covered by vehicle warranty.

To clean the dashboard, instrument panel, and gauge lens covers, use a cloth dampened with warm soapy water. Make certain to wring the cloth out well before cleaning, as excess water will damage the electrical components.

Vinyl Upholstery Cleaning

To prevent soiling, frequent vacuuming or light brushing to remove dust and dirt is recommended. Harsh cleaning agents can cause permanent damage to vinyl upholstery.

To preserve the upholstery and prevent damage, carefully review the following sections for recommended cleaning procedures. Waxing or refinishing improves soil resistance for all vinyls. Any hard wax, such as that used on automobiles, may be used.

If stains do not respond to any of the treatments described above, it is sometimes helpful to expose the vinyl to direct sunlight for up to 30 hours. Mustard, ball point ink, certain shoe polishes, and dyes often bleach out in direct sunlight, leaving the vinyl undamaged.

Ball Point Ink

Ball point ink can sometimes be removed if rubbed immediately with a damp cloth, using water or rubbing alcohol. If this does not work, try the procedure used for sulfide stains.

Chewing Gum

Harden the gum with an ice cube wrapped in a plastic bag, then scrape it off with a dull knife. Remove any remaining traces of gum with an all-purpose light oil (peanut butter will also work). Wipe off the gum and oil substance.

Dirt

Wash the upholstery with warm water and mild soap, such as saddle or oil soap. Apply soapy water to a large area and allow to soak for a few minutes, then rub briskly with a cloth to remove the dirt. This can be repeated several times, as necessary.

If dirt is deeply imbedded, use a soft bristle brush after applying the soap.

If dirt is extremely difficult to remove, wall-washing preparations normally found around the home can be used. Powdered cleaners, such as those used for

sinks and tiles, are abrasive and must be used with caution as they can scratch the vinyl or give it a permanent dull appearance.

Nail Polish and Nail Polish Remover

Prolonged contact with these substances causes permanent damage to vinyl. Careful blotting immediately after contact minimizes damage. Do not spread the liquid during removal.

Paint, Shoe Heel Marks

Paint should be removed immediately. Do not use paint remover or liquid-type brush cleaner on vinyl. An unprinted cloth, dampened with naphtha or turpentine may be used. Use care to prevent contact with parts of the upholstery that are not vinyl.

Shoe Polish

Most shoe polishes contain dyes which penetrate vinyl and stain it permanently. Shoe polish should be wiped off as quickly as possible using naphtha or lighter fluid. If staining occurs, try the procedure used for sulfide stains.

Sulfide Stains

Sulfide compounds, such as those found in eggs and some canned goods, can stain after prolonged contact with vinyl. Remove these stains by placing a clean, unprinted piece of cloth over the spotted area and pouring a liberal amount of 6 percent hydrogen peroxide onto the cloth. Allow the saturated cloth to remain on the spot for 30 to 60 minutes. For stubborn spots, allow the saturated cloth to remain on the area overnight. Use caution to prevent the solution from seeping into the seams, where it can weaken the cotton thread.

Tars, Asphalts, and Creosote

Each of these items stains vinyl after prolonged contact. They should be wiped off immediately and the area carefully cleaned, using a cloth dampened with naphtha.

Velour Upholstery Cleaning

To prevent soiling, frequent vacuuming or light brushing to remove dust and dirt is recommended. Spot clean with a mild solvent or an upholstery shampoo,

Vehicle Appearance and Care

or the foam from a mild detergent. When using a solvent or a dry-cleaning product, follow the instructions carefully, and clean only in a well-ventilated area. Avoid any product that contains carbon tetrachloride or other toxic materials. With either method, pretest a small area before proceeding. Use a professional upholstery cleaning service when extensive cleaning is needed.

Chewing Gum or Wax

Harden the gum or wax with an ice cube wrapped in a plastic bag, then scrape it off with a dull knife. Excess wax can be absorbed by placing a thick white blotter over the wax and heating with a warm (not hot) iron. Remove the remainder by using the procedure for grease and oil-based stains.

Grease and Oil-Based Stains

Dampen a small absorbent cloth with dry-cleaning solvent or spot remover. Apply the cloth carefully to the spot from the outer edge to the center. Pat and blot the spot with a clean, dry cloth. Repeat as necessary, turning the cloth so that the stain does not redeposit on the fabric.

Mildew

Brush the dry fabric with a soft brush. Sponge with detergent, and blot. If the fabric is colorfast, dilute a teaspoon of bleach in one quart (one liter) of cool water. Apply with a swab, directly on the mildew stain. Dab repeatedly with clear, cool water, and blot dry.

Sugar and Water-Based Stains

Apply water-based detergent or cleaner, working in circular motions. Pat and blot as dry as possible. Repeat, if necessary, before drying thoroughly.

Star Gauge Face Care

Use only a damp cloth to clean gauge faces. A mild detergent solution may be used. Wipe dry with a clean dry cloth.

Care of Exterior Lights

Clean the headlight lenses by hand only. Use a flannel cloth with mild, non-caustic soap or detergent, and water.

NOTICE

Do not use a power buffer, paper towels, chemical solvents, or abrasive cleaners on the headlight lens, all of which can remove the UV coating from the surface, and result in yellowing of the lens.

21

In An Emergency

Hazard Warning Lights	21.1
Fire Extinguisher	21.1
Emergency Kit	21.1
Emergency Filter Replacement, DAVCO Fuel/Water Separator	21.1
Starting with Jumper Cables	21.2
Towing	21.4
Fire in the Cab	21.6

In An Emergency

Hazard Warning Lights

The hazard warning light flasher (**Fig. 21.1**) is typically part of the multifunction turn signal switch. To operate the hazard lights, pull the tab out. All of the turn signal lights and both of the indicator lights on the control panel will flash. To cancel the hazard warning lights, push the turn signal control lever either up or down, then return the lever to its neutral position.

Western Star vehicles may be equipped with an optional hazard warning light switch located on the right-hand dash panel. To operate the hazard lights, press the upper half of the switch. To cancel the hazard warning lights, press the lower half of the switch.

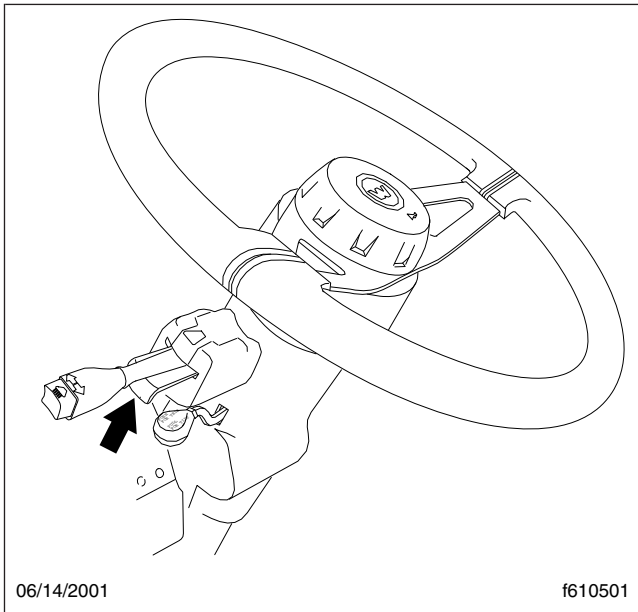

Fig. 21.1, Hazard Warning Light Switch Tab (left-hand drive shown)

Fire Extinguisher

An optional factory-installed fire extinguisher may be located in the cab by the driver's door, between the seats, or in the sleeper baggage compartment, if equipped.

Emergency Kit

An optional emergency triangle reflector package, flare kit, and (on vehicles with a DAVCO fuel/water

separator) a spin-on fuel filter element may be supplied in the cab.

WARNING

Use extreme care when placing flares in emergency situations that involve exposure to flammable substances such as fuel. An explosion or fire could occur causing serious personal injury.

If there is an emergency while driving, cautiously pull off the road, paying attention to other traffic. Turn on the hazard warning lights. Place the flares and reflector along the side of the road to alert other drivers that an emergency situation exists.

Emergency Filter Replacement, DAVCO Fuel/Water Separator

If the filter cover on the DAVCO fuel/water separator is broken, it will not be possible to operate the vehicle. A standard spin-on filter will correct this problem.

Refer to the DAVCO website (www.davcotec.com) for additional information, .

WARNING

Fluid circulated through the fuel/water separator to heat the fuel may be diesel fuel returned from the engine, or engine coolant. Drain the fuel/water separator only when the engine and fluids have cooled. Draining it when the engine is hot could cause severe personal injury due to scalding.

If returning fuel is released into the atmosphere, its vapors can ignite in the presence of any ignition source. Do not expose the fuel to, or work with the fuel system near, open flame or intense heat. To do so could cause fire, possibly resulting in serious personal injury or property damage.

1. Shut down the engine and set the parking brake. Chock the tires.

IMPORTANT: When draining fluid from a fuel/water separator, drain the fluid into an appropriate container, and dispose of it properly. Many

jurisdictions now issue fines for draining fuel/water separators onto the ground.

- Put a clean receptacle under the fuel/water separator and attach a piece of hose to the drain valve, to direct fuel into the receptacle.

NOTE: Use a hose with a ½-inch pipe thread to fit the drain valve on a Fuel Pro 382.

- Remove the vent cap (Fig. 21.2, Item 4) and open the drain valve (Fig. 21.2, Item 1). Drain the fuel to just below the collar level, then close the drain valve.

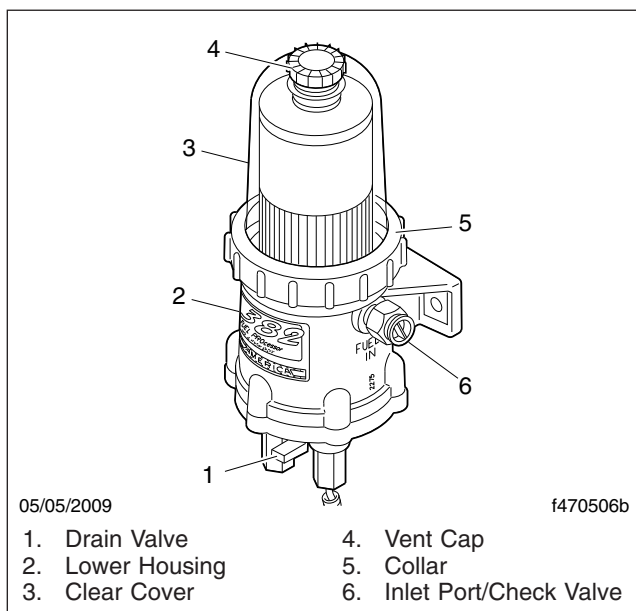

Fig. 21.2, DAVCO Fuel/Water Separator (Fuel Pro 382 shown)

- Using a DAVCO collar wrench (Fig. 21.3), remove the clear cover and collar.

NOTE: Broken vent cap and collar warranty claims will not be accepted if any tool other than a DAVCO collar wrench, p/n 380134, 382002, or 232007, is used for removal. During installation, the vent cap and collar are to be **hand-tightened only**, not tightened with a wrench.

- Remove the filter and dispose of it in an environmentally acceptable manner.
- Clean all threads and sealing surfaces very thoroughly. Even a small amount of dirt will prevent

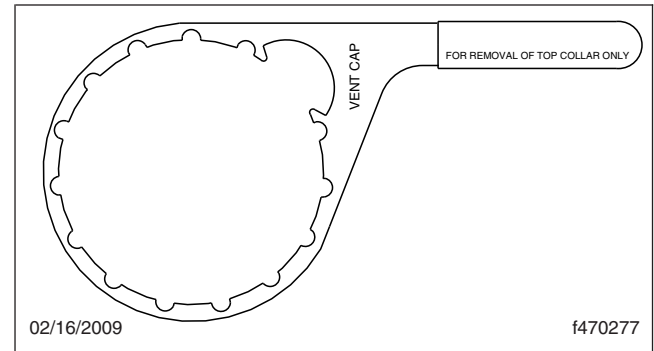

Fig. 21.3, DAVCO Collar Wrench

the fuel/water separator from sealing, and an air leak will result.

- Ensure that the drain valve is closed.
- Remove the filter grommet from the filter stud, if equipped.
- Fill the housing to the top with clean diesel fuel.
- Install a standard engine spin-on filter (part number FF105 or equivalent) on the filter stud.
- Install the cover O-ring, clear cover, and the collar. Hand-tighten the collar.
- Install the O-ring in the vent cap, then install and hand-tighten the vent cap on the fuel/water separator.
- Start the engine. When the lubricating oil reaches its normal operating pressure, increase engine speed to high idle for one to two minutes to purge air from the system.

Starting with Jumper Cables

WARNING

Batteries release explosive gas. Do not smoke when working around batteries. Put out all flames and remove all sources of sparks or intense heat in the vicinity of the battery. Do not allow the vehicles to touch each other. Do not lean over the batteries when making connections, and keep all other persons away from the batteries. Failure to follow these precautions could lead to severe personal injury as a result of an explosion or acid burns.

In An Emergency

NOTICE

Make sure both electrical systems are the same voltage. Electronic devices on both vehicles can be damaged when connected to a vehicle with a different operating voltage.

IMPORTANT: Do not attempt to jump start a damaged or frozen battery.

1. Set the parking brake and turn off all lights and other electrical devices. Ensure that the vehicles are not touching and both ignition switches are turned to the OFF position.
2. Access the batteries by removing the battery box cover, if equipped.

NOTICE

Always connect the batteries and jumper cables correctly (positive-to-positive and negative-to-negative). Connecting a charging device backwards (positive-to-negative) can severely damage the vehicle electrical content and cause non-warrantable failures.

IMPORTANT: On vehicles equipped with optional jump start posts, connect to these posts instead of the battery terminals. Jump start posts may be installed in various locations on the vehicle. See [Fig. 21.4](#).

3. Connect the positive (+) jumper cable to the positive terminal or jump start post on the discharged battery. See [Fig. 21.5](#).
4. Connect the other end of the positive jumper cable to the positive terminal or jump start post on the booster battery providing the charge.

WARNING

Do the next step exactly as instructed and do not allow the clamps of one cable to touch the clamps of the other cable. Otherwise, a spark could occur near a battery, possibly resulting in severe personal injury from explosion or acid burns.

5. Connect the negative (-) jumper cable to the negative terminal or jump start post on the booster battery.

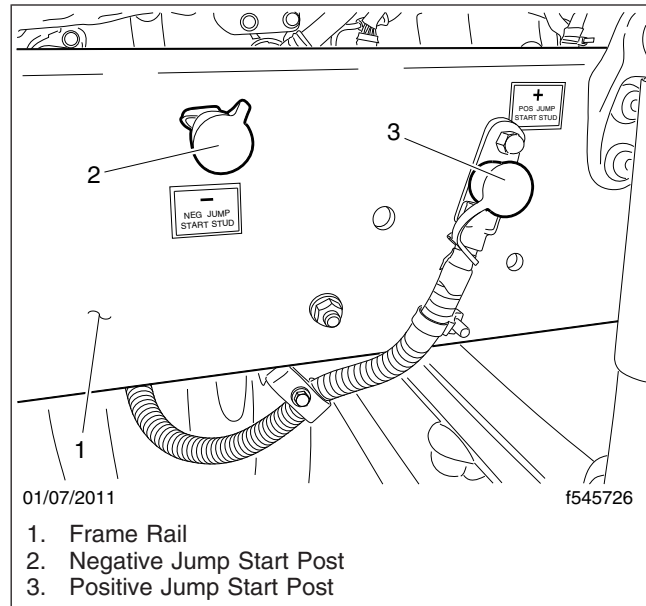

Fig. 21.4, Possible Jump Start Post Location (passenger-side engine compartment)

6. Connect the other end of the negative jumper cable to the negative ground stud on the vehicle requiring the jump start.
7. Start the engine of the vehicle providing the jump start and let the engine run a few minutes to charge the batteries of the other vehicle.
8. Attempt to start the engine of the vehicle receiving the jump. Do not operate the starter longer than 30 seconds, and wait at least two minutes between starting attempts to allow the starter to cool.
9. When the engine starts, let it idle a few minutes.

WARNING

Do the next step exactly as instructed and do not allow the clamps of one cable to touch the clamps of the other cable. Otherwise, a spark could occur near a battery, possibly resulting in severe personal injury from explosion or acid burns.

10. Disconnect the negative jumper cable from the jump started vehicle.
11. Disconnect the negative jumper cable from the vehicle that provided the jump start.

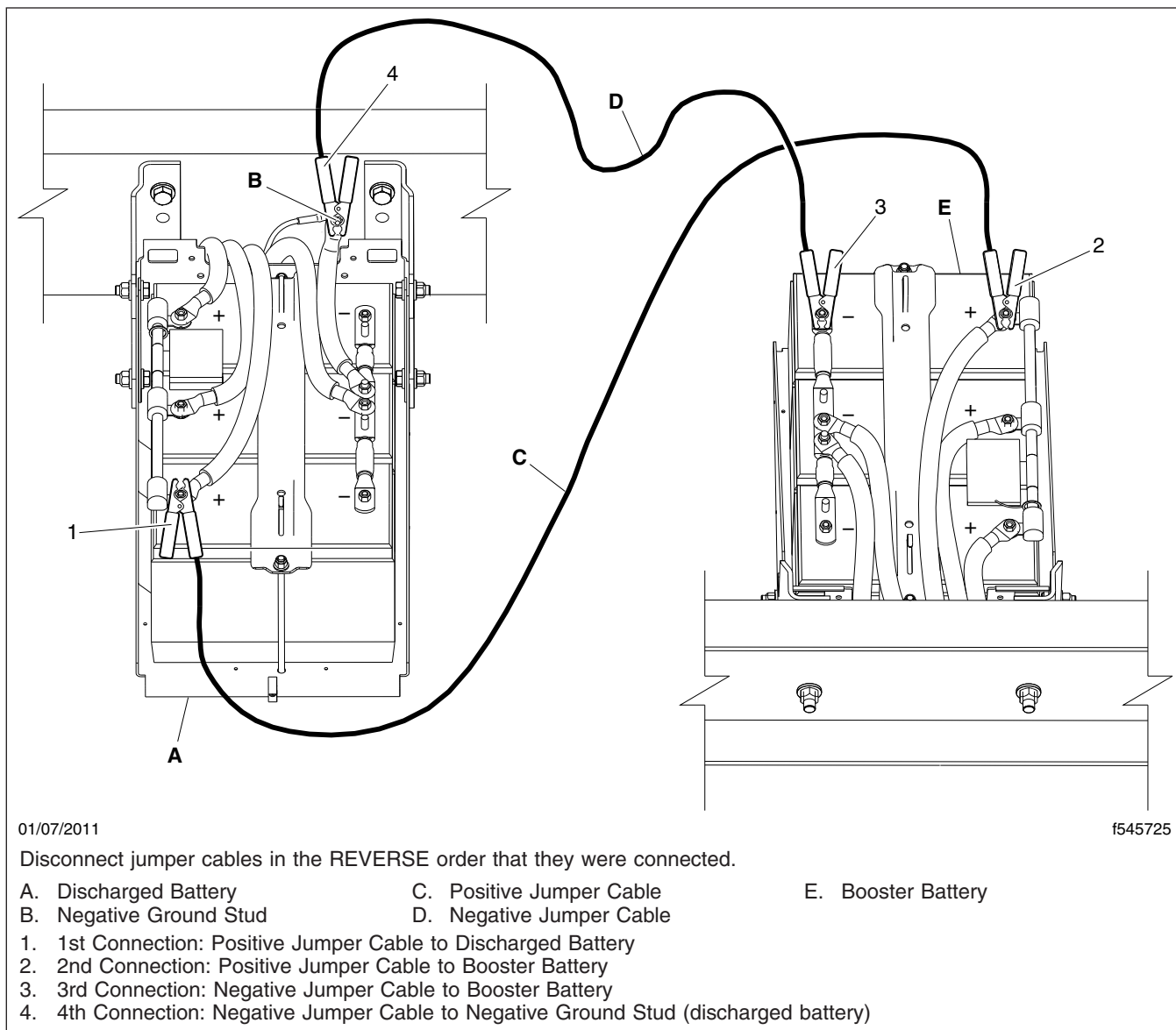

Fig. 21.5, Jumper Connections

12. Disconnect the positive cable from the vehicle that provided the jump start.
13. Disconnect the other end of the positive cable from the jump started vehicle.
14. Install the battery box cover, if equipped.

Towing

When it is necessary to tow the vehicle, make sure the instructions below are closely followed to prevent damage to the vehicle.



Do not tow an unbraked vehicle if the combined weight of both vehicles is more than the sum of

In An Emergency

the gross axle weight ratings (GAWR) of the towing vehicle. Otherwise brake capacity will be inadequate, which could result in personal injury or death.

Front Towing Hookup

1. Disconnect the batteries at the negative terminals.

NOTICE

Failure to remove the axle shafts or the driveline when towing the vehicle with the rear wheels on the ground could result in damage to the transmission and other parts.

2. Remove the driveline from any drive axle that will have its wheels touching the ground while the vehicle is towed,

or

remove the drive axle shafts on both sides of the vehicle from any drive axle that will have its wheels touching the ground while the vehicle is towed.

3. If the axle shafts were removed, cover the ends of the hubs with metal plates or plywood cut to fit the axle opening, and drilled to fit the axle shaft studs. This prevents lubricant from leaking out and will keep contaminants from getting into and damaging the wheel bearings and axle lubricant. If the driveline(s) were removed, ensure the U-joint caps are secure so they will not come off.

NOTICE

Failure to protect the frame rails from the chains could cause damage, leading to eventual frame failure.

4. If a vehicle with tandem rear axles is to be lifted and towed, chain the forward rear-axle assembly to the vehicle frame. This will prevent the forward rear-axle assembly from dropping and keep its wheels off the ground while being towed.

Use protection to keep the chains from damaging the frame.

5. Remove the bumper extension and chrome bumper, if so equipped. Remove the bumper fairing, if so equipped.

NOTICE

Do not pass a sling (for example, a rope or chain) from one tow hook to another to fasten for towing. Known as reeving, this practice is *not* permissible in most industrial applications of towing and hoisting. Reeving can overload the hooks and result in damage to the vehicle.

6. Attach the towing device. Due to the many variables that exist in towing, positioning the lifting and towing device is the sole responsibility of the towing-vehicle operator.
7. On vehicles equipped with an air fairing, measure the distance from the ground to the bumper, or from the ground to a frame bracket.
8. Lift the vehicle, and secure the safety chains. If extra towing clearance is needed, remove the front wheels.

 **WARNING**

Failure to lower the vehicle could result in the air fairing striking an overhead obstruction, such as a bridge or overpass, and causing vehicle damage or personal injury.

9. On vehicles equipped with an air fairing, repeat the measurement taken in step 8. The difference between the two measurements must not exceed 14 inches (36 cm). If necessary, lower the vehicle.
10. Connect the clearance lights, taillights, and signal lights. Connect any special towing lights required by local regulations.

 **WARNING**

Failure to chock the tires or connect the tow truck's air brake system before releasing the spring parking brakes could allow the disabled vehicle to suddenly roll. This could cause property damage or personal injury.

11. Chock the tires on the disabled vehicle and connect the towing vehicle's air brake system to the vehicle being towed. Then, release the spring parking brakes and remove the chocks.

Rear Towing Hookup

NOTICE

Using a rear towing hookup on a vehicle equipped with a roof fairing could cause damage to the cab structure.

If reverse towing at speeds above 45 mph (70 kph) is necessary, hold down the cab with tension straps looped over the cab shocks and under the frame rails. Failure to do so could allow the wind load to lift the cab unexpectedly, resulting in damage to the air springs and other components.

1. If the vehicle is equipped with cab air suspension, and reverse towing at speeds above 45 mph (70 kph) is necessary, hold down the cab as follows:
 - 1.1 Drain the air from the cab air springs.
 - 1.2 Loop a 2-inch (5-cm) ratchet-style tension strap (rated 2000 lb [900 kg] minimum work load) over the top of the cab shock and under the frame rail. See [Fig. 21.6](#). Tighten the strap for a snug fit. If the cab is equipped with two or more shocks, restrain the aftmost shock on each side of the vehicle.
2. Place the front tires straight forward and secure the steering wheel in this position.
3. Disconnect the battery ground cables.

NOTICE

Failure to protect the frame rails from the chains could cause damage, leading to eventual frame failure.

4. On dual drive axles, using protection to keep the chains from damaging the vehicle frame, chain the forward-rear drive axle to the frame.
5. Attach the towing device.

NOTE: Due to the many variables that exist in towing, positioning the lifting and towing device is the sole responsibility of the towing-vehicle operator.

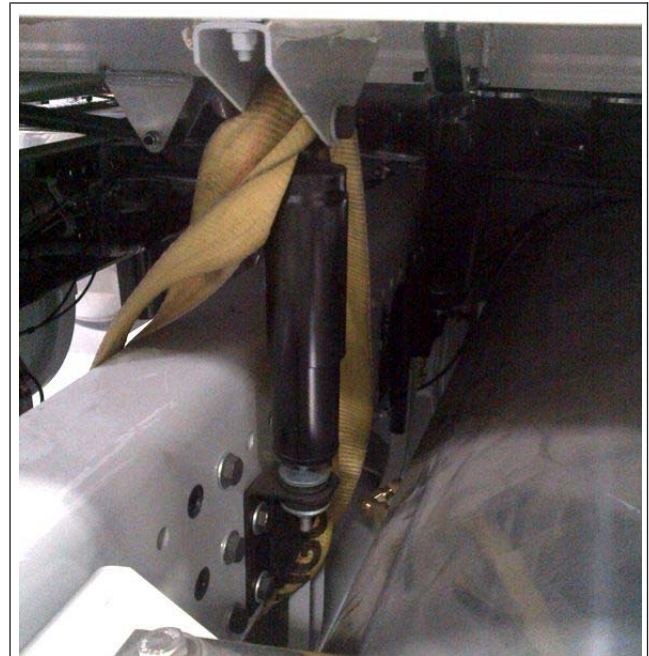

06/24/2014

f602530

NOTE: Typical cab air suspension shown.

Fig. 21.6, Tension Strap Installed to Hold Down the Cab

6. Lift the vehicle and secure the safety chains. If extra clearance is needed, remove the bumper extension if equipped.
7. Connect the clearance lights, taillights, and signal lights. Also connect any special towing lights required by local regulations.

Fire in the Cab

According to data from the National Highway Traffic Safety Administration, the incidence of fire in heavy- and medium-duty trucks is rare. Federal Motor Vehicle Safety Standard #302 limits the flammability of specified materials used inside the cab, but despite this, most materials will burn. The cab of this vehicle contains urethane foam, which is flammable.

WARNING

Urethane foam is flammable! Do not allow any flames, sparks, or other heat sources such as cigarettes or light bulbs to contact urethane foam. Urethane foam in contact with such heat sources could cause a serious, rapid fire, which

In An Emergency

could result in death, severe burns, or gas poisoning, as well as damage to the vehicle.

In Case of a Cab Fire

As quickly as possible, bring the vehicle to a safe stop, apply the parking brake, turn off the ignition, and get out of the vehicle.

22

Pre- and Post-Trip Checklists

Periodic Inspections and Maintenance, General Information	22.1
Checklists	22.1
Fluids Added	22.2

Pre- and Post-Trip Checklists

Periodic Inspections and Maintenance, General Information

Regulations in Canada and the U.S. clearly indicate that it is the driver's responsibility to perform an inspection, and ensure the complete road-worthiness of a vehicle, before placing it into service. Commercial vehicles may be subject to inspection by authorized inspectors, and an unsafe vehicle can be taken "out of service" until the driver or owner repairs it.

Use the following checklists to ensure that vehicle components are in good working condition before each trip. Careful inspections eliminate stops later to fix overlooked or forgotten items.

The checklists in this chapter can be copied and kept as a record that the procedures have been completed. For details on how to inspect each item on the checklists, see the corresponding procedure (step number) in [Chapter 23](#).

Checklists

NOTE: Checklists in this chapter correspond with the procedures and steps in [Chapter 23](#), *Pre- and Post-Trip Inspections and Maintenance*. Your vehicle may not be equipped with all components listed below.

Daily Pretrip Inspection Checklists

See the following tables for a list of procedures that should be performed daily, before the first trip. Place a check mark in the complete (**Comp.**) column to indicate a procedure has been performed.

Inspector	Date

Suspension and Slack Adjusters		Comp.
1	Suspension components	
2	Slack adjusters	

Wheels and Tires		Comp.
1	Wheel Covers	
2	Tire condition	
3	Tire inflation	
4	Rims and wheel components	

Wheels and Tires		Comp.
5	Wheel bearing oil seals and lubrication levels	
6	Mud Flaps	

Saddle Tank Areas		Comp.
1	Drain air reservoirs (without automatic drain valves)	
2	Fuel tank(s) secure	
3	Frame rails and crossmembers	
4	Visible exhaust components	

Engine Compartment		Comp.
1	Leakage under engine	
2	Air intake system	
3	Engine oil level	
4	Power steering reservoir level	
5	Engine coolant level	
6	Visible engine wiring	
7	Frame rails	

Cab		Comp.
1	Reset dash-mounted air intake restriction indicator	
2	Air-pressure warning systems	
3	Air governor cut-in and cut-out pressures	
4	Air pressure build-up time	
5	Air system leakage	
6	Air pressure reserve	
7	Mirrors, windows, windshield	
8	Horn, windshield wipers, windshield washers	
9	Heater and defroster	
10	Interior lights	
11	Exterior lights	
12	Seat belts and tether belts	
13	Fuel level	
14	Mirror adjustment	
15	Service brakes	
16	Backup alarm	

Pre- and Post-Trip Checklists

Weekly Post-trip Inspection Checklist

See the following table for procedures that should be performed weekly, post-trip. Place a check mark in the complete (**Comp.**) column to indicate a procedure has been performed.

Inspector		Date

Engine Compartment		Comp.
1	Windshield washer reservoir level	
2	Air intake restriction indicator	
3	Allison transmission fluid level	
4	Water in fuel/water separator	
5	Steering components	
6	Serpentine drive belts	

Fluids Added

Use the following table to note any fluids that were added during the inspection and maintenance procedures.

Fluids Added During Inspection	
Fluid	Amount Added
Wheel Bearing Oil Seal Lubricant	
Engine Oil	
Power Steering Fluid	
Engine Coolant	
Windshield Washer Fluid	
Automatic Transmission Fluid	
Hydraulic Clutch Fluid (DOT 4 brake fluid)	

Monthly Post-trip Inspection Checklists

See the following tables for procedures that should be performed monthly, post-trip. Place a check mark in the complete (**Comp.**) column to indicate a procedure has been performed.

Inspector		Date

Brake Components		Comp.
1	Brake system components	
2	Brake chambers	
3	Air brake lines	
4	Flex air hoses	
5	Brake linings and brake drums	
6	Brake lining thickness	

Saddle Tank Areas		Comp.
1	Drain air reservoirs (with automatic drain valves)	
2	Batteries (location may vary)	
3	Aerodynamic components	

Engine Compartment		Comp.
1	Hood and bumper	
2	Hydraulic clutch reservoir	
3	Radiator and heater hoses	
4	Steering wheel play	

23

Pre- and Post-Trip Inspections and Maintenance

Safety Precautions	23.1
Daily Pretrip Inspections and Maintenance	23.1
Weekly Post-Trip Inspections and Maintenance	23.9
Monthly Post-Trip Inspections and Maintenance	23.12

Pre- and Post-Trip Inspections and Maintenance

Safety Precautions



When working on the vehicle, shut down the engine, set the parking brake, and chock the tires. Before working under the vehicle, always place jack stands under the frame rails to ensure the vehicle can not drop. Failure to follow these steps could result in serious personal injury or death.

Daily Pretrip Inspections and Maintenance

Complete the following inspection and maintenance procedures to ensure that vehicle components are in good working condition before each trip. A driver that is familiar with the vehicle and drives it regularly can perform the daily inspections, then add the weekly and monthly post-trip inspections as scheduled.

If the driver does not operate the vehicle on a consistent basis, all daily, weekly, and monthly inspection and maintenance procedures should be performed before the trip.

IMPORTANT: The pre- and post-trip checklists, inspections, and maintenance procedures detailed in this chapter are **not all-inclusive**. Refer to other component and body manufacturers' instructions for specific inspection and maintenance instructions, as well as local, state, and federal guidelines.

NOTE: If any system or component does not pass this inspection, it must be corrected before operating the vehicle. Whenever equipment requires adjustment, replacement, and/or repair, see the *Western Star Workshop Manual* for procedures and specifications.

Suspension and Slack Adjuster Inspection

Walk around the vehicle and visually inspect suspension and slack adjuster components.

1. Inspect the following suspension components for signs of structural damage, cracks, or wear.
 - springs

- spring hangers
- shocks
- suspension arms
- suspension brackets
- axle seats
- bushings

2. Inspect slack adjusters for signs of damage. See [Fig. 23.1](#), [Fig. 23.2](#), or [Fig. 23.3](#).

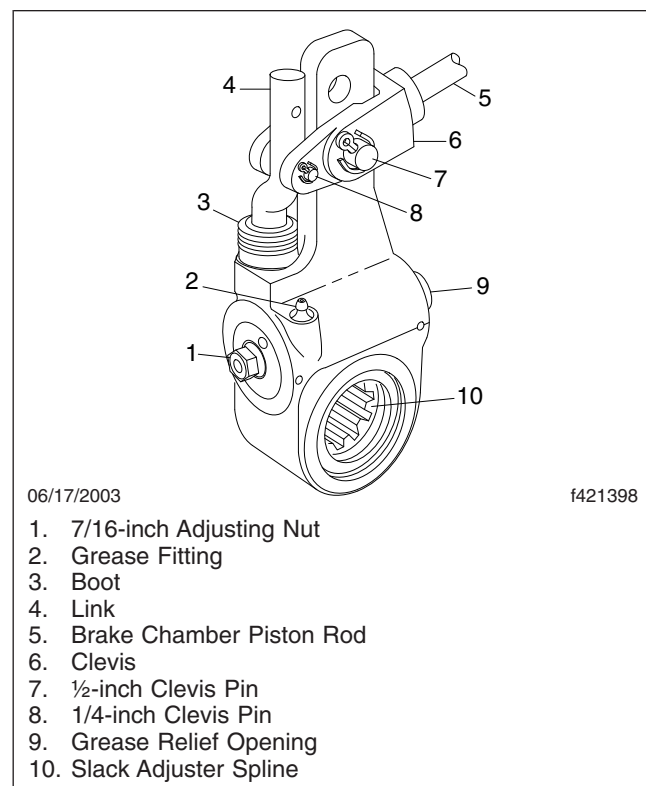

Fig. 23.1, Gunite Automatic Slack Adjuster

- Inspect slack adjuster boots, if equipped, for cuts or tears.
- Inspect anchor straps, if equipped, for damage.
- Look for worn clevis pins on brake chamber pushrods.
- Look for missing or damaged cotter pins on the clevis pins.

Pre- and Post-Trip Inspections and Maintenance

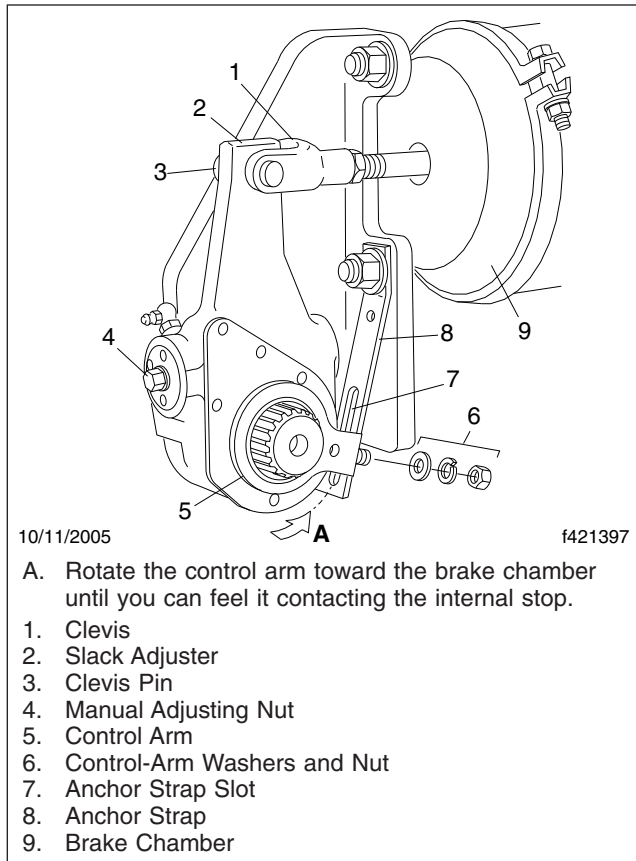

Fig. 23.2, Haldex Automatic Slack Adjuster

- Ensure chamber piston rods are in line with the slack adjusters.

Wheel and Tire Inspection

Walk around the vehicle and visually inspect each wheel and tire assembly.

IMPORTANT: Wheel covers decrease drag force as a vehicle moves, thereby improving fuel efficiency. If replacement of a wheel cover is necessary, the replacement cover must meet or exceed the drag reduction performance of the originally installed cover in order to maintain compliance with greenhouse gas and full efficiency regulations (GHG14).

1. If the vehicle was originally equipped with wheel covers, ensure all wheel covers are present. Inspect wheel covers for damage or wear. Remove wheel covers from rear drive wheels, if equipped,

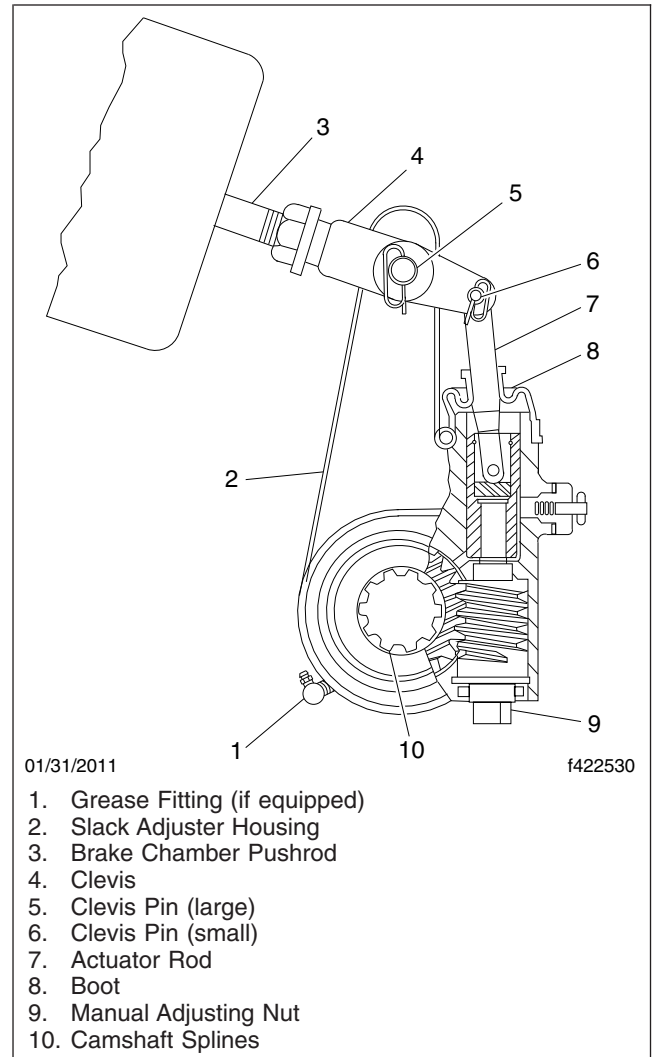

Fig. 23.3, Meritor Automatic Slack Adjuster

prior to inspecting the tires and wheel components.

NOTE: During wheel cover installation, ensure the V-notch in the liner inner retaining ring is centered on the valve stem. The inner and outer retaining rings should be uniformly aligned to each other and to the wheel rim. The outer retaining ring of the liner is equipped with two canvas flaps. When installing the face cover, make sure the cover retaining ring is inserted between the two canvas flaps on the liner outer retaining ring so that the Velcro strips line up

Pre- and Post-Trip Inspections and Maintenance

between the face cover and the liner. Make certain the detachable view cover is centered on the face cover, and the Velcro strips are pressed firmly in place.

2. Inspect each tire for the following:

- valve stem caps on every tire, screwed on finger-tight
- bulges, cracks, cuts, and penetrations
- oil contamination (petroleum derivatives will soften the rubber and destroy the tire)
- tread depth—if tread is less than 4/32 inch (3 mm) on any front tire, or less than 2/32 inch (1.5 mm) on any rear tire, replace the tire
- debris lodged between dual tire sets

IMPORTANT: Low-rolling resistance (LRR) tires minimize wasted energy as a tire rolls, thereby decreasing rolling effort and improving fuel efficiency. If tire replacement is necessary, replacement tires must meet or exceed the rolling resistance of the originally installed tires in order to maintain compliance with greenhouse gas and full efficiency regulations (GHG14).

Contact your tire manufacturer/supplier to determine the rolling resistance of the originally installed tires. Visit www.epa.gov/smartway for additional information and resources.

WARNING

Do not operate the vehicle with underinflated or overinflated tires. Incorrect inflation can stress the tires and make the tires and rims more susceptible to damage, possibly leading to rim or tire failure and loss of vehicle control, resulting in serious personal injury or death.

3. Check tire inflation.

For inflation pressures and maximum loads, see the tire manufacturer's guidelines. Inflate the tires to the applicable pressures if needed.

If a tire has been run flat or under-inflated, check the wheel and tire for damage before adding air.

Keep compressed air reservoirs and lines dry during tire inflation. Use well-maintained inline moisture traps and service them regularly.

NOTICE

A weekly pressure loss of 4 psi (28 kPa) or more in a tire may indicate damage. The tire should be inspected and, if necessary, repaired or replaced by a qualified tire service facility.

IMPORTANT: The load and cold inflation pressure must not exceed the rim or wheel manufacturer's recommendations, even though the tire may be approved for a higher load inflation. Consult the rim or wheel manufacturer for the correct tire inflation pressure for the vehicle load.

4. Examine each rim and wheel component. Check the wheel nuts or rim nuts for indications of looseness.

- 4.1 Remove all dirt and debris from the assembly. Rust streaks or metal build-up around stud holes, or out-of-round or worn stud holes, may be caused by loose wheel nuts.

WARNING

Have any worn or damaged wheel components replaced by a qualified person using the wheel manufacturer's instructions and the wheel industry's standard safety precautions and equipment. Otherwise a vehicle or workshop accident could occur, possibly resulting in serious personal injury or death.

- 4.2 Inspect for broken, cracked, badly worn, bent, rusty, or sprung rings and rims. See [Fig. 23.4](#).

NOTICE

Use the recommended torque values and follow the proper tightening sequence. Insufficient wheel nut torque can cause wheel shimmy, resulting in wheel damage, stud breakage, and extreme tire tread wear. Excessive wheel nut torque

Pre- and Post-Trip Inspections and Maintenance

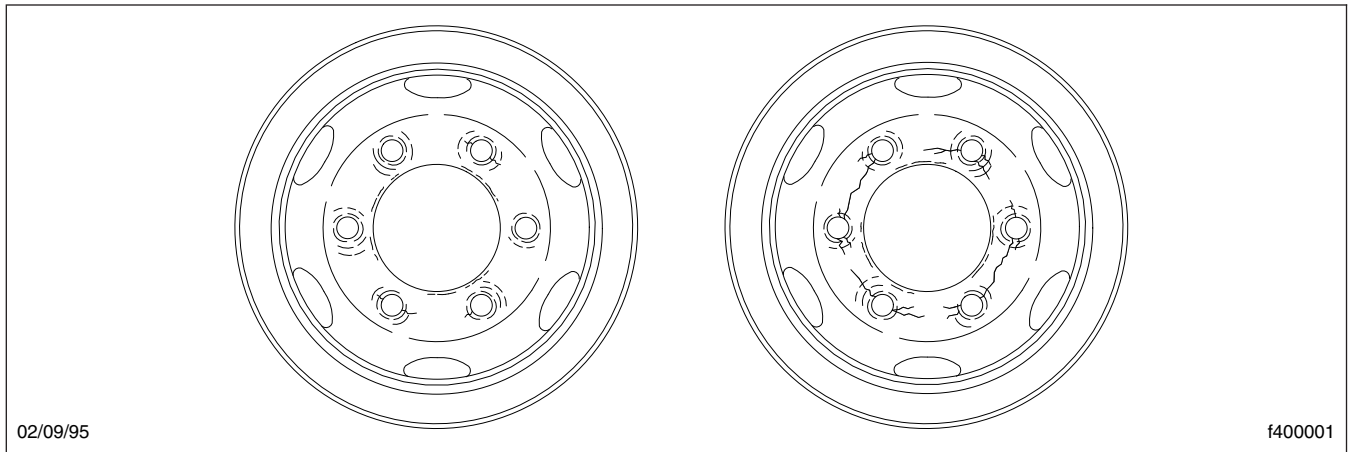

Fig. 23.4, Worn Stud Holes

can break studs, damage threads, and crack discs in the stud hole area.

- 4.3 Make sure all wheel nuts are tightened. If tightening is necessary, use the tightening pattern in [Fig. 23.5](#) or [Fig. 23.6](#).

When tightening a 12-stud wheel rim, use the tightening sequence in [Fig. 23.7](#) for each of the three stages of tightening as follows:

- Stage 1—Tighten each nut 50 lbf-ft (68 N·m)
- Stage 2—Tighten each nut 100 lbf-ft (136 N·m)
- Stage 3—Tighten each nut 150 lbf-ft (203 N·m)

5. Inspect the outboard side of all wheel hubs and the hub oil seal area on the inboard side of each wheel for signs of oil leakage. If any oil is found on wheel and tire or brake components, remove the vehicle from service until the leak has been fixed.

If needed, fill the hubs to the level indicated on the hub cap. See **Group 35** of the *Western Star Maintenance Manual* for recommended lubricants.

6. Check that mud flaps are undamaged and hang 10 inches (25.4 cm) or less from the ground.

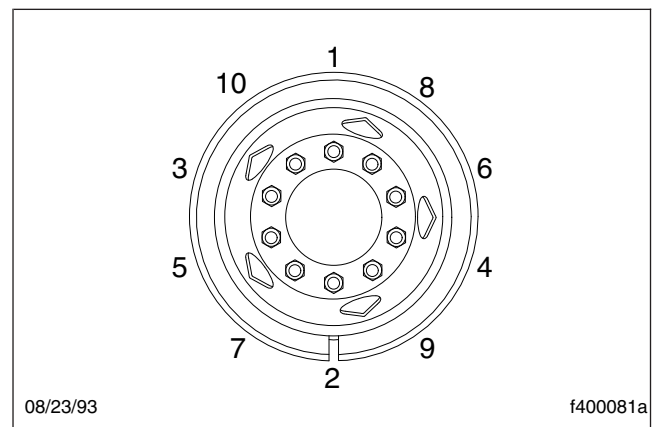

Fig. 23.5, Tightening Sequence, 10-Stud Disc Wheels

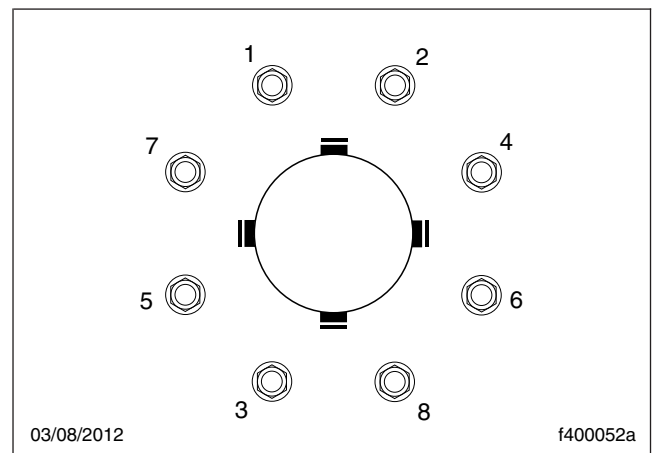

Fig. 23.6, Tightening Sequence, 8-Stud Disc Wheels

Pre- and Post-Trip Inspections and Maintenance

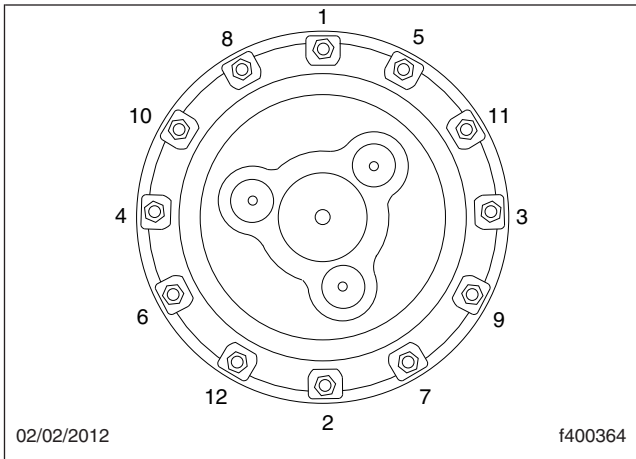

Fig. 23.7, Tightening Sequence, 12-Stud Wheel Rims

Saddle Tank Areas Inspection

WARNING

When draining the air reservoir, do not look into the air jets or direct them toward anyone. Dirt or sludge particles may be in the airstream and could cause injury.

NOTICE

If the water drained from the air reservoirs is cloudy or oily, it may indicate a problem with the compressor. If oil is allowed to contaminate the air dryer, it will not remove the water from the air brake system, which could adversely affect braking.

1. Drain the brake system air reservoirs (reservoirs without automatic drain valves only).

WARNING

Never operate the engine with the fuel tank shut-off valves partially closed. This could damage the fuel pump, causing sudden loss of engine power, possibly resulting in serious personal injury due to reduced vehicle control.

2. Ensure fuel tanks are secured to their mounting brackets and that the mounting brackets are secured to the frame.

If equipped with fuel tank shutoff valves, be sure the valves are fully open.

3. Inspect visible frame rails for missing bolts, shiny areas, or rust streaks. Check all visible cross-members for damage or signs of looseness.
4. Inspect visible components of the exhaust system to ensure connections are tight.

Inspect upstream of the aftertreatment device (ATD), if equipped, for cracking or signs of leaks, such as soot trails. Inspect downstream of the ATD for signs of exhaust leaks, such as blistering or warping of nearby components.

Engine Compartment Inspection

1. Check the ground underneath the engine for fuel, oil, or coolant leaks.
2. Inspect the air intake system for leaks or damage.

NOTICE

Failure to maintain a sealed air intake system could allow the entry of dirt and contaminants into the engine. This could adversely affect engine performance and result in engine damage.

- 2.1 Push the reset button on the air intake restriction indicator located on the air cleaner, if equipped.
 - 2.2 Check the air intake duct from the air cleaner to the engine intake. Make sure the duct components are secure and airtight.
 - 2.3 Check the vacuator (spitter) valve(s) for damage, and make sure the lips of the valve(s) are pliable and free of debris.
3. Check the engine oil level.

NOTICE

Operating the engine with the oil level below the minimum fill (or "add") mark or above the maximum fill (or "full") mark could result in engine damage.

- 3.1 Check the oil level with the vehicle parked on a level surface. See the engine manufacturer's guidelines for engine shutdown time requirements prior to checking the oil level.

Pre- and Post-Trip Inspections and Maintenance

IMPORTANT: On engines that comply with EPA07 or newer regulations, use CJ-4 engine oil with less than 1% sulfated ash. Failure to use CJ-4 oil may void the warranty on emission aftertreatment components.

3.2 If the oil level is at or below the minimum fill (or "add") mark on the dipstick, add enough oil to maintain the level between the minimum and maximum fill marks. See the engine operation manual for recommended lubricants.

4. Check the power steering reservoir fluid level.

The power steering fluid level should be between the MIN COLD mark and the middle mark just above it. See [Fig. 23.8](#). If needed, fill the reservoir with automatic transmission fluid that meets Dexron III or TES-389 specifications.

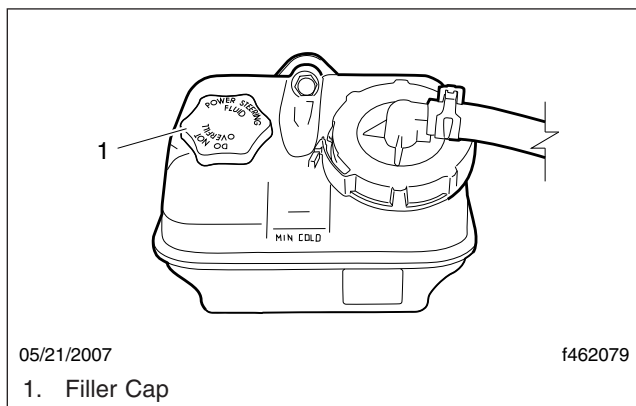

Fig. 23.8, Power Steering Fluid Reservoir (configuration may vary)

NOTICE

Low coolant could result in engine overheating, which could cause engine damage.

IMPORTANT: The surge tank must be cool to check the coolant level.

5. Check the engine coolant level in the radiator surge tank.

- **Steel Surge Tank:** Ensure coolant is visible in the sight glass. See [Fig. 23.9](#). If coolant is not visible, add a 50/50 mixture of water and antifreeze to the surge tank until coolant is visible in the sight glass. Start the

engine after refilling and check the sight glass again when the engine is at operating temperature.

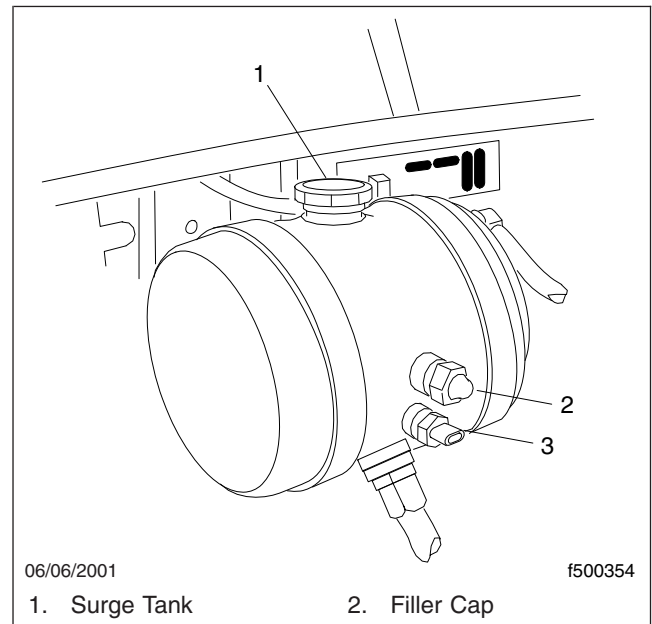

Fig. 23.9, Steel Surge Tank

- **Translucent Surge Tank:** If the coolant is low, fill the surge tank to the FULL line with a 50/50 mixture of water and antifreeze. See [Fig. 23.10](#). Start the engine after refilling and check the level again when the engine is at operating temperature.
6. Inspect visible engine wiring for damage or looseness. See [Fig. 23.11](#). Check for loose wiring, chafed insulation, and damaged or loose hold-down clamps.
 7. Inspect visible frame rails for missing bolts, shiny areas, or rust streaks.

Cab Inspection

1. Push the reset button on the dash-mounted air intake restriction indicator, if equipped.
2. With the ignition switch in the OFF position, check the air-pressure warning system.
 - 2.1 If not previously drained, drain the air reservoirs using moderate brake applications until pressure in both reservoirs is less than 70 psi (483 kPa).

Pre- and Post-Trip Inspections and Maintenance

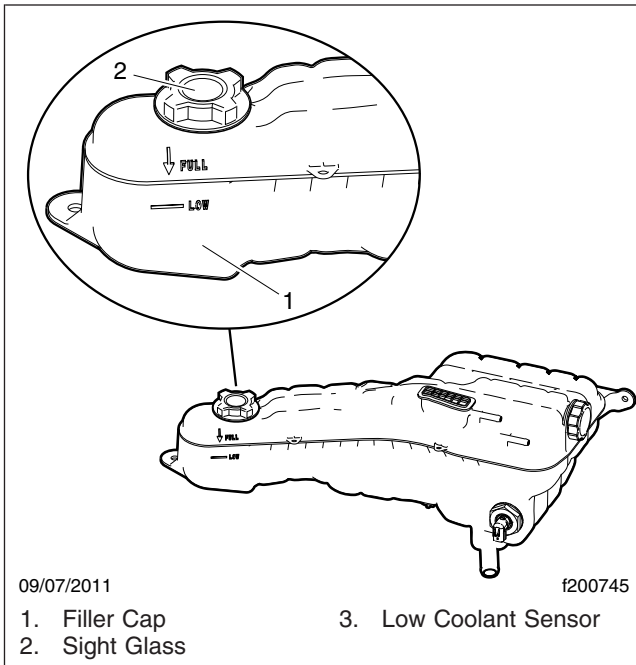

Fig. 23.10, Plastic Surge Tank

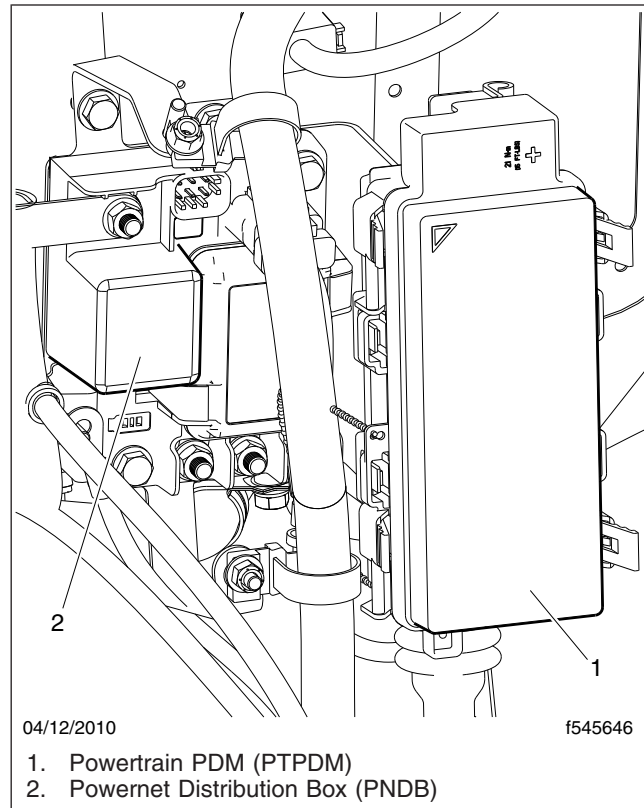

Fig. 23.11, Visible Engine Wiring

- 2.2 Turn the ignition to the ON position. The ICU will complete a full gauge sweep and bulb check, and the warning buzzer will sound. Ensure the BRAKE AIR lamp remains illuminated and the warning buzzer continues to sound after the gauge sweep is complete.
3. Check air governor cut-in and cut-out pressures.
 - 3.1 Start the engine and ensure the BRAKE AIR lamp goes out and the buzzer silences when pressure reaches approximately 70 psi (483 kPa) in both air reservoirs.

The air governor should cut out at approximately 120 psi (827 kPa). For vehicles with an optional dryer reservoir module (DRM), the cut-out pressure is approximately 130 psi (896 kPa).
 - 3.2 With the engine idling, apply the brake pedal several times. The air governor should cut in when pressure in the primary air reservoir (top air gauge) reaches approximately 100 psi (689 kPa).
4. Check air pressure build-up time.

- 4.1 With the air system fully charged, make one full brake application and note the air pressure reading on the primary air gauge.
- 4.2 Further reduce air pressure using moderate brake applications, then run the engine at governed rpm.
- 4.3 Note the time that the pressure reaches the previously noted reading on the primary air gauge, then note the time that the air pressure reaches cut-out pressure.
- 4.4 If it takes longer than 30 seconds to reach cut-out pressure after the primary air gauge passes the previously noted pressure (noted after one full brake application), eliminate any leaks or replace the air compressor before operating the vehicle.
5. Check air leakage in the system.

Pre- and Post-Trip Inspections and Maintenance

- 5.1 With the parking brake applied, the transmission out of gear, and the air system fully charged, release the service brakes and shut down the engine.
- 5.2 Wait one minute and note the air pressure drop in psi (kPa) per minute from the primary air reservoir.

If the pressure drop exceeds the limits shown in **Table 23.1**, eliminate any leaks before operating the vehicle.

6. Check the air pressure reserve.

With the engine still off, make one full brake application and observe the pressure drop on the primary air gauge. If pressure drops more than 25 psi (172 kPa), eliminate any leaks before operating the vehicle.

Maximum Allowable Air Leakage		
Description	Pressure Drop: psi (kPa) Per Minute	
	Released	Applied
Truck or Tractor Only	2 (14)	3 (21)
Truck or Tractor w/Single Trailer	3 (21)	4 (28)

Table 23.1, Maximum Allowable Air Leakage

WARNING

When cleaning windshields and windows, always stand on the ground or on a secure ladder or platform. Use a long-handled window cleaner. Do not use the cab steps, tires, fenders, fuel tanks, engine, or under-hood components to access the windshield or windows. Doing so could cause a fall and result in an injury.

7. Inspect the mirrors, window glass, and windshield for cracks or other damage.
8. Ensure that the horn, windshield wipers, and windshield washers are operating properly. These devices must be in good working order for safe vehicle operation.
9. Ensure the heater and defroster are operating properly.
10. Check the operation of all interior lights.

- 10.1 Turn on the headlights and leave them on. Ensure all equipped gauge bulbs illuminate in the dash message center.
- 10.2 Ensure all equipped driver control switches illuminate.
- 10.3 Ensure both turn signal indicator bulbs illuminate in the dash message center when the turn signal switch is activated.

11. Check the operation of all exterior lights. See **Fig. 23.12**.

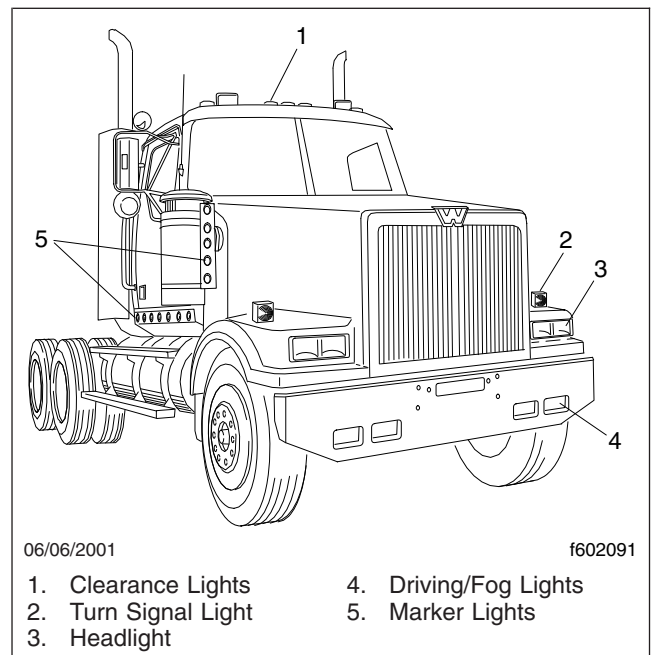

Fig. 23.12, Exterior Lights

- 11.1 Activate the high-beam headlights and hazard warning lights.
- 11.2 Exit the cab and check that all exterior lights and reflectors are clean and intact.
- 11.3 Check that the brake lights, taillights, headlights, turn signals, marker lights, identification lights, and clearance lights are working properly.
12. Inspect the seat belts and tether belts.

Pre- and Post-Trip Inspections and Maintenance

WARNING

Inspect and maintain seat belts. When any part of a seat belt system needs replacement, the entire seat belt must be replaced, both retractor and buckle side. Any time a vehicle is involved in an accident, and the seat belt system was in use, the entire vehicle seat belt system must be replaced before operating the vehicle. Do not attempt to modify the seat belt system; doing so could change the effectiveness of the system. Failure to replace worn or damaged seat belts, or making any modifications to the system, may result in personal injury or death.

- 12.1 Check the web for fraying, cuts, extreme dirt and dust, or for severe fading from exposure to sunlight, especially near the buckle latch plate and in the D-loop guide area.
- 12.2 Check operation of the buckle, latch, Komfort Latch or Sliding Komfort Latch (if equipped), web retractor, and upper seat belt mount on the door pillar. Check all visible components for wear or damage.
- 12.3 Check the seat belt and tether belt connection points and tighten any that are loose.

WARNING

Never fill fuel tanks to more than 95 percent of their liquid capacity. This could make them more likely to rupture from impact, possibly causing fire and resulting in serious personal injury or death by burning.

Do not mix gasoline or alcohol with diesel fuel. This mixture could cause an explosion, possibly resulting in serious personal injury or death. Do not fill the fuel tanks in the presence of sparks, open flames, or intense heat. These could ignite the fuel, possibly causing severe burns.

IMPORTANT: On engines that comply with EPA07 or newer regulations, use ultralow-sulfur diesel (ULSD) with 15 ppm sulfur content or less. Failure to use ULSD fuel may void the warranty on emission components.

13. Check the fuel level in the fuel tank(s). To keep condensation to a minimum, fuel tanks should be filled at the end of each day.
14. Adjust the rearview and down view mirrors as necessary.
15. Test the service brakes.
 - 15.1 With the engine running and air system fully charged, set the parking brake.
 - 15.2 Put the vehicle in the lowest gear and gently attempt to move it forward. The vehicle should not move.

If the vehicle moves, the parking brakes are not operating correctly and must be repaired before the vehicle is operated.
16. Test the backup alarm
 - 16.1 Release the parking brake and put the transmission in reverse.
 - 16.2 Move the vehicle slightly backward to ensure that the backup alarm is operating correctly.

Weekly Post-Trip Inspections and Maintenance

Engine Compartment Inspection

WARNING

Washer fluids may be flammable and poisonous. Do not expose washer fluid to an open flame or any burning material, such as a cigarette. Always comply with the washer fluid manufacturer's recommended safety precautions.

1. Check the windshield washer reservoir fluid level. The reservoir is usually located near the right-hand frame rail.
2. After resetting the air intake restriction indicator during the daily pretrip inspection, check the indicator again with the engine off.
 - 2.1 Check an indicator with graduations to see if air restriction exceeds the value shown in [Table 23.2](#).

Check a go/no-go indicator without graduations to see if the colored bar shows through the clear window.

Pre- and Post-Trip Inspections and Maintenance

Air Intake Maximum Restriction Values (inH ₂ O)			
Engine Make	Pre-EPA07 Engines	EPA07 and EPA10 Engines	GHG14 Engines
Detroit	20	22	18
Cummins	25	25	25
Mercedes-Benz	22	22	–
Caterpillar	25	–	–

Table 23.2, Air Intake Maximum Restriction Values

- 2.2 If air restriction exceeds the maximum allowable value, operate the vehicle for one more day, making sure not to run the engine over rated rpm. Refer to the engine operation manual for more information on rated rpm for your engine.
- 2.3 If air restriction exceeds the maximum value again, replace the air cleaner. For instructions, refer to **Group 09** of the *Western Star Workshop Manual*.
3. If the vehicle is equipped with an Allison automatic transmission, check the automatic transmission fluid level.
4. Check for water in the fuel/water separator, if equipped.

IMPORTANT: When draining fluid from a fuel/water separator, drain the fluid into an appropriate container and dispose of it properly. Many jurisdictions now issue fines for draining fuel/water separators onto the ground.

- 4.1 Place a suitable container under the fuel/water separator.

NOTE: A hose may be used to direct water into the container. Use a hose with a ½-inch pipe thread on DAVCO models.

- 4.2 If the engine is equipped with a built-in water separator, loosen the drain valve, and allow the water to run out. Close the drain valve, taking care not to overtighten it.
- 4.3 *Alliance/Racor Models:* Turn the drain plug counterclockwise to open it. See [Fig. 23.13](#).

DAVCO Models: Remove the vent cap and open the drain. See [Fig. 23.14](#).

ConMet Models: Check the water level in the sight bowl, if so equipped. To drain the water, loosen the valve at the bottom and allow the water to run out. See [Fig. 23.15](#).

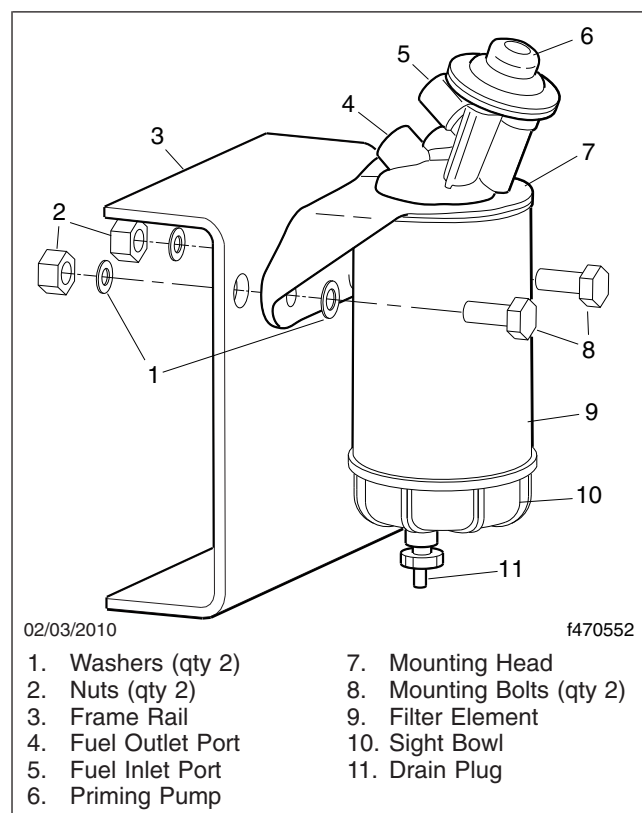

Fig. 23.13, Alliance Fuel/Water Separator Assembly and Installation

- 4.4 Stop draining fluid when fuel begins to drain out.

Alliance/Racor Models: turn the drain plug clockwise to close it.

DAVCO Models: close the drain valve. Install and hand-tighten the vent cap.

ConMet Models: close and tighten the valve finger-tight.

5. Inspect the steering components.

Pre- and Post-Trip Inspections and Maintenance

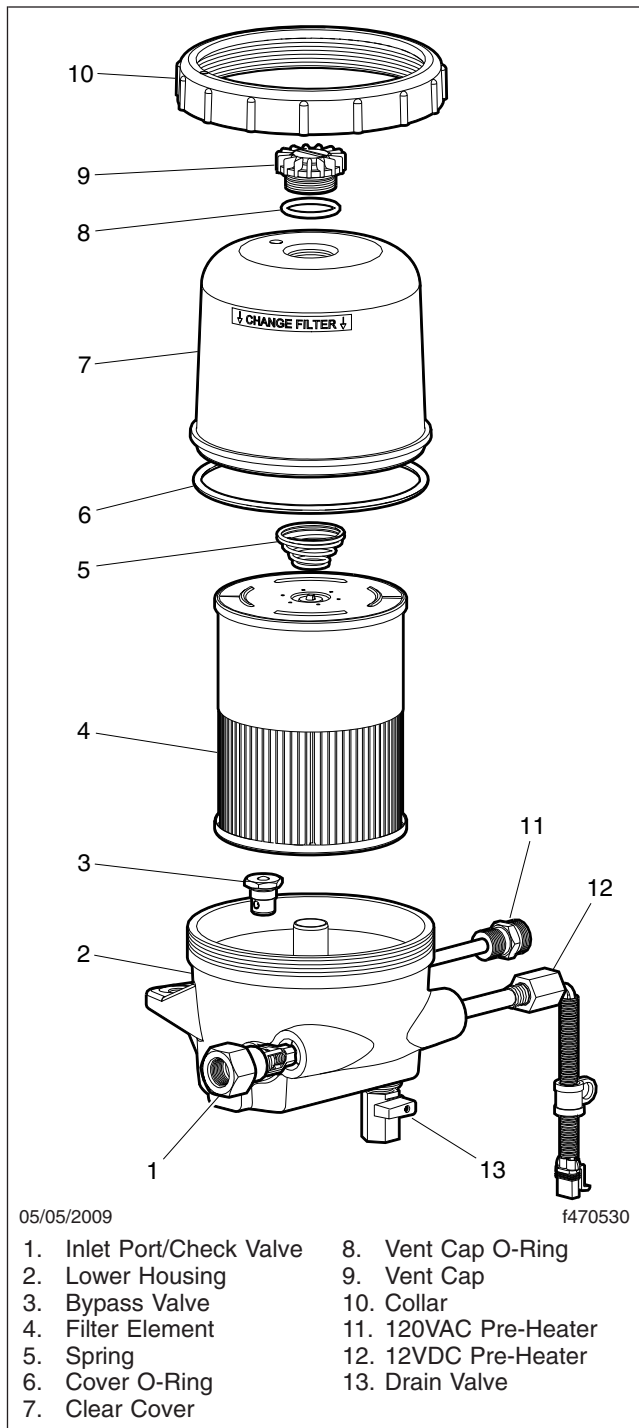

Fig. 23.14, DAVCO Fuel/Water Separator (Fuel Pro 482 shown)

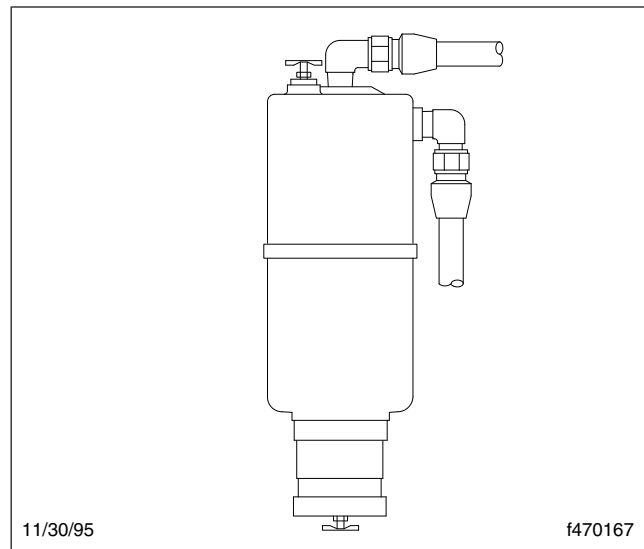

Fig. 23.15, ConMet Fuel/Water Separator

- 5.1 Inspect tie rods, steering arms, and the drag link for signs of looseness (i.e., shiny spots or rust tracks).
- 5.2 Check the steering gear mounting bolts and pitman arm nut for signs of looseness.
- 5.3 Check the drag link nuts for missing cotter pins.
- 5.4 Inspect the steering intermediate shaft and end yokes for excessive looseness or other damage.

NOTICE

Do not drive with a drive belt that is visibly worn or damaged. If it fails, the lack of coolant flow could rapidly cause damage to engine components.

6. Inspect the serpentine drive belts for signs of glazing, frayed edges, breaks, cracks, or oil contamination.

Pre- and Post-Trip Inspections and Maintenance

Monthly Post-Trip Inspections and Maintenance

Brake Component Inspection

Walk around the vehicle and visually the brake system components for visible damage.

1. Inspect all visible brake system components for missing fasteners or signs of looseness, such as rust tracks.

NOTICE

If the external breather tube or breather cap is missing or incorrectly installed, road dirt and debris can adversely affect the operation of the brake chamber. Once inside of the chamber, dirt and debris can cause the internal parts of the chamber to deteriorate faster.

2. Inspect the exterior surfaces of brake chambers for damage. Make sure that breather holes are open and free of debris.

NOTE: Do not route air brake lines on top of anything likely to be stepped on.

3. Inspect air brake lines for dents, swelling, kinks, twisting, abrasion, and damage, especially near moving parts.
4. Inspect flex air hoses for deterioration or signs of abrasion.
5. Inspect for cracked, worn, or oil-contaminated brake linings and brake drums (or rotors).
6. Check the thickness of the brake linings. Replace brake linings on all brake assemblies on the axle if any brake linings are worn to less than approximately 1/4 inch (6.4 mm) at the thinnest point.

Saddle Tank Areas Inspection

WARNING

When draining the air reservoir, do not look into the air jets or direct them toward anyone. Dirt or sludge particles may be in the airstream and could cause injury.

NOTICE

If the water drained from the air reservoirs is cloudy or oily, it may indicate a problem with the compressor. If oil is allowed to contaminate the air dryer, it will not remove the water from the air brake system, which could adversely affect braking.

1. Drain the brake system air reservoirs (reservoirs with automatic drain valves only).

NOTE: Battery locations vary between vehicles.

2. Inspect the batteries.

WARNING

Battery posts, terminals, and related accessories contain lead and lead compounds, chemicals known to the State of California to cause cancer and reproductive harm. To prevent possible personal injury, always wash your hands after handling battery parts and related accessories.

- 2.1 Remove the battery box cover and inspect all visible battery cables for loose wiring or damage.
- 2.2 Check that the battery hold-down is secure.

IMPORTANT: Aerodynamic components decrease drag force as a vehicle moves, thereby improving fuel efficiency. If replacement of an aerodynamic component is necessary, replacement components must meet or exceed the drag reduction performance of the originally installed component in order to maintain compliance with greenhouse gas and full efficiency regulations (GHG14).

3. Inspect the following aerodynamic components, if equipped, for structural damage, cracks, or wear.
 - Chassis fairings
 - Roof fairing/deflector
 - Side skirts
 - Cab/sleeper extenders
 - Battery access cover

Pre- and Post-Trip Inspections and Maintenance

Engine Compartment Inspection and Adjustments

IMPORTANT: If replacement of the hood or bumper is necessary, the replacement component must meet or exceed the drag reduction performance of the originally installed item in order to maintain compliance with greenhouse gas and full efficiency regulations (GHG14).

1. Inspect the bumper and hood for structural damage, cracks, or wear.
2. Check the hydraulic clutch reservoir, if equipped. If necessary, add DOT 4 brake fluid.
3. Inspect the radiator and heater hoses, including the clamps and support brackets.
 - 3.1 Inspect the radiator and charge air cooler for damage and accumulated debris. Straighten bent or damaged fins to permit airflow across all areas of the cores.

NOTE: When traveling through areas of high insect concentration, it may be necessary to clean the exterior of the radiator or the charge air cooler core as often as every 200 miles (320 km).

- 3.2 Make sure the radiator inlet and outlet hoses are pliable and are not cracking or ballooning.
- 3.3 Make sure the heater hoses are pliable and are not cracking or ballooning.
- 3.4 Tighten hose clamps as necessary.

IMPORTANT: Do not overtighten hose clamps, as hose life can be adversely affected.

- 3.5 Ensure hose support brackets are securely fastened. Make sure hoses are not located near sources of wear, abrasion, or high heat.

IMPORTANT: When replacing hoses, install service-type knitted or braided yarn-reinforced neoprene hose. Extended-service-life silicone hoses may also be used. See the Alliance Parts Catalog at www.alliancebrandparts.com or contact your Freightliner Dealer.

4. Check the steering wheel for excessive play.

- 4.1 Start the engine. With the front tires straight ahead, turn the steering wheel until motion is observed at the front wheels.
- 4.2 Align a reference mark on the steering wheel to a rule, then slowly turn the steering wheel in the opposite direction until motion is again detected at the wheels.
- 4.3 Measure the lash (free play) at the rim of the steering wheel. Excessive lash exists if steering wheel movement exceeds 2-1/2 inches (64 mm) with a 20-inch (508-mm) steering wheel, or 2-1/4 inches (57 mm) with an 18-inch (450-mm) steering wheel.
- 4.4 If there is excessive lash, check the steering system for wear or incorrect adjustment before operating the vehicle.

Index

Subject	Page
A	
ABTS Seat	6.4
Armrest Adjustment	6.5
Backrest Adjustment	6.5
Cushion Extension Adjustment	6.5
Isolator	6.5
Lumbar Adjustment	6.5
Seat Height Adjustment	6.5
Seat Tilt Control	6.5
Shoulder Belt Height Control	6.5
Track Adjustment	6.5
Adjustable Steering Column Controls	4.12
Adjusting Headlight Aim	19.1
Air Brake System	12.1
Automatic Slack Adjusters	12.3
Brake System Conditions	12.3
Brake System Operation	12.1
General Information, Brake System	12.1
Air-Suspension Dump Valve	18.1
Allison Automatic Transmissions	15.5
Allison Transmission Operation	15.6
General Information, Allison Transmissions	15.5
Auxiliary Braking Applications	10.3
Engine Brake	10.3
Exhaust Brake	10.4
B	
Back-of-Cab Access	2.5
Accessing Back-of-Cab Area	2.6
Exiting Back-of-Cab Area	2.6
Battery Access	8.3
Battery Disconnect Switches	8.2
Cab Load Disconnect Switch, EPA10 and Newer	8.2
Pre-EPA10 Battery Isolation Switch	8.2
Bostrom Seat	6.3
Backrest Tilt	6.3
Bottom Cushion Tilt	6.4
Fore-and-Aft Seat Slide	6.4
Height Adjustment	6.4
Isolator	6.4
Lumbar Support	6.3
Brake Controls	4.11
Antilock Braking System	4.12
Parking Brake Control Valve	4.11

Subject	Page
Trailer Air Supply Valve	4.12
Trailer Brake Lever	4.12
C	
Cab Amenities	7.2
Cigar Lighter/Accessory Plug	7.2
Cup Holders	7.2
Electronic Device Mount	7.3
Glove Box	7.2
Lighting	7.3
Storage Areas	7.3
Cab Climate Control Panels	5.1
Controls	5.1
Modes	5.3
Cab Washing and Polishing	20.1
Care of Fiberglass Parts	20.1
Canadian Motor Vehicle Safety Standard Labels	1.1
Care of Chrome Parts	20.1
Care of Exterior Lights	20.3
Checking Headlight Aim	19.1
Checklists	22.1
Daily Pretrip Inspection Checklists	22.1
Monthly Post-trip Inspection Checklists	22.2
Weekly Post-trip Inspection Checklist	22.2
Climate Control Options	5.1
Climate Controls	4.13
Clutch	14.7
Clutch General Information	14.7
Clutch Maintenance	14.8
Clutch Operation	14.7
Component GWR Label	1.1
Component Information Label	1.1
Control Panels	4.1
DataStar Display Module	4.1
Cruise Control	10.2
Cruise at a particular speed	10.2
Disengage cruise control	10.2
D	
Daily Pretrip Inspections and Maintenance	23.1
Cab Inspection	23.6
Engine Compartment Inspection	23.5
Saddle Tank Areas Inspection	23.5

Subject	Page	Subject	Page
Suspension and Slack Adjuster Inspection	23.1	Aftertreatment System Indicators Label	1.2
Wheel and Tire Inspection	23.2	Certified Clean Idle Label	1.4
Dashboard Care	20.1	EPA Noise Emission Control Label	1.2
Diesel Exhaust Fluid and Tank, EPA10 and Newer Engines	11.3	Vehicle Emission Control Information Label	1.2
DEF Tank	11.4	Engine Cooling	9.3
DEF Warnings and Engine Limits	11.6	Engine Idle Limiting	10.1
Diesel Exhaust Fluid	11.3	California Engine Idle Limit	10.1
Fuel/DEF Gauge	11.5	Idle Shutdown Timer	10.1
Door Locks and Handles	2.1	Engine Operation	9.1
Remote Keyless Entry	2.1	Cold-Weather Operation	9.2
Drive Axles with Differential Lock	16.1	Engine Break-In	9.2
Differential Lock Operation	16.1	Normal Operation	9.2
Differential Lock Switch	16.1	Safety and Environmental Considerations	9.1
E			
Eaton Fuller Deep Reduction Transmissions	14.4	Engine Protection—Warning and Shutdown	10.1
Downshifting Deep Reduction Transmissions	14.7	Engine Shutdown	9.3
General Information	14.4	Engine Starting	9.1
Upshifting Deep Reduction Transmissions	14.5	Cold-Weather Starting	9.1
Eaton Fuller Splitter and Range-Shift Transmissions	14.1	Starting After Extended Shutdown	9.1
Eaton Fuller 10-Speed Range-Shift Transmissions	14.4	EPA-Regulated Emissions Aftertreatment Systems	11.1
Eaton Fuller 13-Speed Splitter and Range-Shift Transmissions	14.2	ATS Warning Lamps	11.3
Eaton Fuller 18-Speed Splitter and Range-Shift Transmissions	14.3	EPA07 Engines	11.1
General Information, Range-Shift Transmissions	14.1	EPA10 and Newer Engines	11.1
General Information, Splitter Control	14.1	Maintenance	11.3
Eaton® Fuller® Automated Transmissions	15.1	Regeneration	11.2
Automated Transmission Operation	15.1	F	
General Information, Automated Transmissions	15.1	Federal Motor Vehicle Safety Standard Labels	1.1
Transmission Diagnostics	15.4	Fifth Wheel Coupling	17.1
Eaton® Fuller® Transmission Operation Tips	14.1	Coupling, Fontaine and Holland Fifth Wheels	17.2
Emergency Filter Replacement, DAVCO Fuel/Water Separator	21.1	Coupling, Jost Fifth Wheel	17.4
Emergency Kit	21.1	Fifth Wheel Slide	17.7
Emissions Labels	1.2	Air Slide Operation	17.9
		Manual Slide Operation	17.8
		Fifth Wheel Uncoupling	17.5
		Air-Actuated Uncoupling	17.5
		Manual Uncoupling	17.5
		Fifth Wheels, General Information	17.1
		Air-Suspension Dump Valve	17.1
		Fifth Wheel Lubrication	17.1
		Fire Extinguisher	21.1
		Fire in the Cab	21.6
		In Case of a Cab Fire	21.7

Index

Subject	Page
Fluids Added	22.2

G

Grab Handles and Access Steps	2.2
Entering the Driver's Side, Right-Hand-Drive Vehicles	2.4
Entering the Driver's Side	2.2
Entering the Passenger's Side, Right-Hand-Drive Vehicles	2.5
Entering the Passenger's Side	2.3
Exiting the Driver's Side, Right-Hand-Drive Vehicles	2.5
Exiting the Driver's Side	2.3
Exiting the Passenger's Side, Right-Hand-Drive Vehicles	2.5
Exiting the Passenger's Side	2.4
Greenhouse Gas Emissions and Fuel Consumption Standards	11.1

H

Hazard Warning Lights	21.1
Hood Opening and Closing	2.7
Closing the Hood	2.7
Opening the Hood	2.7
Horn Controls	4.5
Air Horn	4.5
Electric Horn	4.5

I

Ignition Switch	4.1
Interaxle Lock	16.2
Interaxle Lock Operation	16.2
Interaxle Lock Switch	16.2

L

Lighting Controls	4.3
Exterior Light Controls	4.3
Interior Light Controls	4.5

M

Meritor WABCO® Antilock Braking System	12.3
ABS, Trailer Compatibility	12.4
Automatic Traction Control	12.4

Subject	Page
Monthly Post-Trip Inspections and Maintenance	23.12
Brake Component Inspection	23.12
Engine Compartment Inspection and Adjustments	23.13
Saddle Tank Areas Inspection	23.12

N

National Seat	6.4
Backrest Tilt	6.4
Bottom Cushion Fore-and-Aft Slide	6.4
Fore-and-Aft Seat Slide	6.4
Height Adjustment	6.4
Isolator	6.4
Lumbar Support	6.4
Rear Cushion Adjustment	6.4

O

Optional Instruments	3.6
Air Restriction Gauge	3.6
Ammeter	3.7
Application Air Pressure Gauge	3.7
Drive Axle Oil Temperature Gauges	3.8
Engine Oil Temperature Gauge	3.8
Turbocharger Boost Pressure Gauge	3.8
Overhead Instrument Panel, Optional	3.8

P

Periodic Inspections and Maintenance, General Information	22.1
Power Steering System	13.1
Steering Wheel Adjustment	13.1
Power Takeoff (PTO) Governor	10.5
Powertrain Controls	4.6
Aftertreatment System Regen Switches	4.6
Axle Switches	4.6
Cruise Control Switches	4.7
Engine Brake Switches	4.8
Engine Diagnostic Switch (EPA07 vehicles)	4.8
Engine Fan Switch	4.8

Subject	Page	Subject	Page
Exhaust Brake Switch	4.9	Air-Suspension Dump Control Switch	4.13
Idle Speed Switch	4.9	Fifth Wheel Slide Control Switch	4.13
Power Takeoff Controls	4.9		
Transmission Controls	4.10	T	
Preliminary Checks	19.1	Towing	21.4
Premier Trailer Couplings	18.1	Front Towing Hookup	21.5
General Information	18.1	Rear Towing Hookup	21.6
Trailer Hookup	18.1		
Trailer Release	18.2	V	
R		Vehicle Power Distribution	8.1
Roll-Stability Control	12.5	Power Distribution, EPA10 and Newer	8.1
S		Pre-EPA10 Power Distribution	8.2
Safety Precautions	23.1	Vinyl Upholstery Cleaning	20.2
Seat Belts and Tether Belts	6.5	Chewing Gum or Wax	20.3
Seat Belt Inspection	6.6	Grease and Oil-Based Stains	20.3
Seat Belt Operation	6.6	Mildew	20.3
Seat Controls	4.14	Sugar and Water-Based Stains	20.3
Seats, General Information	6.1	Vinyl Upholstery Cleaning	20.2
Sleeper Amenities	7.3	Ball Point Ink	20.2
Baggage Compartment		Chewing Gum	20.2
Doors	7.3	Dirt	20.2
Lighting	7.3	Nail Polish and Nail Polish Remover	20.2
Remote Engine Start	7.3	Paint, Shoe Heel Marks	20.2
Sleeper Door	7.3	Shoe Polish	20.2
Sliding Side Window	7.4	Sulfide Stains	20.2
Vent	7.4	Tars, Asphalts, and Creosote	20.2
Sleeper Climate Control Panels	5.4	W	
Accessory Heaters	5.6	Warning and Indicator Lights	3.1
Controls, Vehicles With ATC	5.4	Engine Protection System	3.3
Controls, Vehicles Without ATC	5.4	Weekly Post-Trip Inspections and Maintenance	23.9
Sleeper Compartment		Engine Compartment Inspection	23.9
Restraints	6.9	Western Star High-Back Seat	6.2
Bunk Restraint Adjustment	6.9	Backrest Tilt	6.2
Standard Instruments	3.3	Bottom Cushion Extension	6.3
Coolant Temperature Gauge	3.4	Fore/Aft Isolator	6.3
Engine Oil Pressure Gauge	3.4	Fore/Aft Seat Slide	6.3
Fuel/Diesel Exhaust Fluid (DEF) Gauge, EPA10 and Newer	3.5	Front Cushion Height	6.3
Primary and Secondary Air Pressure Gauges	3.5	Heater	6.3
Speedometer	3.5	Height Adjustment	6.3
Tachometer	3.5	Lumbar Support	6.2
Voltmeter	3.5	Rear Cushion Height	6.3
Star Gauge Face Care	20.3		
Starting with Jumper Cables	21.2		
Suspension/Trailer Connection Controls	4.13		

Index

Subject	Page
Shock Absorber	6.3
Windows and Mirrors	7.1
Down-View Mirror	7.1
Power Mirrors	7.1
Windows	7.1
Windshield Wiper Controls	4.11